

MOUNTING AND OPERATING INSTRUCTIONS



EB 8484-3 EN

Translation of original instructions



TROVIS 3730-3 Smart Positioner (HART®)

Firmware version 2.00.15



Edition December 2023

Note on these mounting and operating instructions

These mounting and operating instructions assist you in mounting and operating the device safely. The instructions are binding for handling SAMSON devices. The images shown in these instructions are for illustration purposes only. The actual product may vary.

- For the safe and proper use of these instructions, read them carefully and keep them for later reference.
- If you have any questions about these instructions, contact SAMSON's After-sales Service (aftersaleservice@samsongroup.com).



Documents relating to the device, such as the mounting and operating instructions, are available on our website at www.samsongroup.com > **Downloads > Documentation.**

Definition of signal words

DANGER

Hazardous situations which, if not avoided, will result in death or serious injury

WARNING

Hazardous situations which, if not avoided, could result in death or serious injury

NOTICE

Property damage message or malfunction

Note

Additional information

Tip

Recommended action

1	Safety instructions and measures	1-1
1.1	Notes on possible severe personal injury	1-3
1.2	Notes on possible personal injury	1-4
1.3	Notes on possible property damage	1-4
1.4	Special instructions concerning explosion protection	1-5
1.5	Warnings on the device.....	1-7
2	Markings on the device	2-1
2.1	Nameplate	2-1
2.2	Options.....	2-1
2.3	Firmware versions	2-2
2.4	Article code.....	2-2
3	Design and principle of operation	3-1
3.1	Additional equipment.....	3-1
3.1.1	Optional additional functions.....	3-3
3.2	Mounting versions.....	3-4
3.3	Configuration using the TROVIS-VIEW software	3-5
3.4	Technical data	3-6
3.5	Dimensions in mm.....	3-13
3.6	Fixing levels according to VDI/VDE 3845 (September 2010)	3-17
4	Shipment and on-site transport	4-1
4.1	Accepting the delivered goods	4-1
4.2	Removing the packaging from the positioner	4-1
4.3	Transporting the positioner.....	4-1
4.4	Storing the positioner	4-1
5	Installation	5-1
5.1	Installation conditions	5-1
5.2	Preparation for installation.....	5-2
5.3	Turning the positioner shaft	5-2
5.4	Adjusting the lever and pin position.....	5-2
5.4.1	Travel tables	5-4
5.5	Installing a volume restriction	5-5
5.6	Positioner attachment	5-6
5.6.1	Direct attachment	5-6
5.6.2	Attachment according to IEC 60534-6.....	5-8
5.6.3	Attachment to Type 3510 Micro-flow Valve	5-12
5.6.4	Attachment according to VDI/VDE 3847-1	5-12
5.6.5	Attachment according to VDI/VDE 3847-2	5-19

Contents

5.6.6	Attachment according to VDI/VDE 3845	5-26
5.6.7	Reversing amplifier for double-acting actuators	5-30
5.6.8	Attachment of external position sensor	5-30
5.6.9	Attaching positioners with stainless steel housings	5-36
5.6.10	Air purging function for single-acting actuators	5-36
5.7	Establishing pneumatic connections	5-37
5.7.1	Supply air	5-38
5.7.2	Signal pressure connection	5-38
5.7.3	Signal pressure reading	5-39
5.7.4	Supply pressure	5-39
5.8	Establishing electrical connections	5-40
5.8.1	Cable entry with cable gland	5-41
5.8.2	Electrical power	5-42
5.8.3	Establishing HART® communication	5-47
5.8.4	Switching amplifier according to EN 60947-5-6	5-47
5.9	Accessories	5-48
6	Operation	6-1
6.1	Rotary pushbutton	6-1
6.2	AIR TO OPEN/AIR TO CLOSE slide switch	6-2
6.3	Initialization key (INIT)	6-2
6.4	Display	6-3
6.4.1	Display icons	6-4
7	Start-up and configuration	7-1
7.1	First start-up	7-2
7.2	Start-up settings	7-3
7.3	Enabling configuration to change parameters	7-3
7.4	Start-up menu	7-4
7.4.1	Setting the actuator type	7-4
7.4.2	Determining the fail-safe position	7-4
7.4.3	Specifying the pin position	7-5
7.4.4	Setting the nominal range	7-5
7.4.5	Selecting the initialization mode	7-6
7.4.6	Setting the initialization mode	7-7
7.5	Initializing the positioner	7-9
7.6	Adjusting the switching points	7-11
7.6.1	Adjusting the CLOSED position	7-12
7.6.2	Adjusting the OPEN position	7-12

8	Operation	8-1
8.1	Changing the reading direction of the display	8-1
8.2	HART® communication	8-2
8.2.1	Dynamic HART® variables	8-3
8.3	Changing operating mode	8-4
8.4	Performing zero calibration	8-4
8.5	Resetting the positioner	8-5
9	Malfunctions	9-1
9.1	Emergency action	9-6
10	Servicing	10-1
10.1	Cleaning the cover window	10-2
10.2	Firmware updates	10-2
10.3	Periodic inspection and testing of the positioner	10-3
11	Decommissioning	11-1
12	Removal	12-1
13	Repairs	13-1
13.1	Servicing explosion-protected devices	13-1
13.2	Returning devices to SAMSON	13-1
14	Disposal	14-1
15	Certificates	15-1
16	Appendix A (configuration instructions)	16-1
16.1	Code list	16-1
16.1.1	Structure of the main display	16-1
16.1.2	Menu structure and parameters (menu level)	16-1
16.2	Valve characteristic selection	16-21
17	Appendix B	17-1
17.1	After-sales service	17-1

1 Safety instructions and measures

Intended use

The SAMSON TROVIS 3730-3 Positioner is mounted on pneumatic control valves and used to assign the valve position to the control signal. The device is designed to operate under exactly defined conditions (e.g. operating pressure, temperature). Therefore, operators must ensure that the positioner is only used in applications where the operating conditions correspond to the technical data. In case operators intend to use the positioner in other applications or conditions than specified, contact SAMSON.

SAMSON does not assume any liability for damage resulting from the failure to use the device for its intended purpose or for damage caused by external forces or any other external factors.

➔ Refer to the technical data for limits and fields of application as well as possible uses.

Reasonably foreseeable misuse

The TROVIS 3730-3 Positioner is **not** suitable for the following applications:

- Use outside the limits defined during sizing and by the technical data

Furthermore, the following activities do not comply with the intended use:

- Use of non-original spare parts
- Performing maintenance activities not described in these instructions

Qualifications of operating personnel

The positioner must be mounted, started up and serviced by fully trained and qualified personnel only; the accepted industry codes and practices must be observed. According to these mounting and operating instructions, trained personnel refers to individuals who are able to judge the work they are assigned to and recognize possible hazards due to their specialized training, their knowledge and experience as well as their knowledge of the applicable standards.

Explosion-protected versions of this device must be operated only by personnel who has undergone special training or instructions or who is authorized to work on explosion-protected devices in hazardous areas.

Safety instructions and measures

Personal protective equipment

No personal protective equipment is required for the direct handling of the positioner. Work on the control valve may be necessary when mounting or removing the device.

- Observe the requirements for personal protective equipment specified in the valve documentation.
- Check with the plant operator for details on further protective equipment.

Revisions and other modifications

Revisions, conversions or other modifications of the product are not authorized by SAMSON. They are performed at the user's own risk and may lead to safety hazards, for example. Furthermore, the product may no longer meet the requirements for its intended use.

Safety features

Upon failure of the air supply or electric signal, the positioner vents the actuator, causing the valve to move to the fail-safe position determined by the actuator.

Warning against residual hazards

The positioner has direct influence on the control valve. To avoid personal injury or property damage, plant operators and operating personnel must prevent hazards that could be caused in the control valve by the process medium, the operating pressure, the signal pressure or by moving parts by taking appropriate precautions. Plant operators and operating personnel must observe all hazard statements, warning and caution notes in these mounting and operating instructions, especially for installation, start-up and service work.

If inadmissible motions or forces are produced in the pneumatic actuator as a result of the supply pressure, it must be restricted using a suitable supply pressure reducing station.

Responsibilities of the operator

Operators are responsible for proper use and compliance with the safety regulations. Operators are obliged to provide these mounting and operating instructions to the operating personnel and to instruct them in proper operation. Furthermore, operators must ensure that operating personnel or third parties are not exposed to any danger.

Responsibilities of operating personnel

Operating personnel must read and understand these mounting and operating instructions as well as the specified hazard statements, warning and caution notes. Furthermore, the operating personnel must be familiar with the applicable health, safety and accident prevention regulations and comply with them.

Referenced standards, directives and regulations

Devices with a CE marking fulfill the following requirements of the Directives:

- TROVIS 3730-3: 2011/65/EU, 2014/30/EU
- TROVIS 3730-3-110/-510/-810/-850: 2011/65/EU, 2014/30/EU, 2014/34/EU

Devices with an EAC marking fulfill the requirements of the following Regulations:

- TROVIS 3730-3: TR CU 020/2011 and TR CU 012/2011 with the applicable GOST standards:
 - GOCT 31610.0-2014 (IEC 60079-0:2011)
 - GOCT 31610.11-2014 (IEC 60079-11:2011)
- TROVIS 3730-3-110/-510/-810/-850: TR CU 020/2011

See the Appendix for declarations of conformity and EAC certificates.

Referenced documentation

The following documents apply in addition to these mounting and operating instructions:

- Operating instructions for valve diagnostics: ► EB 8389-3
- The mounting and operating instructions of the components on which the positioner is mounted (valve, actuator, valve accessories etc.).

1.1 Notes on possible severe personal injury



Risk of fatal injury due to the formation of an explosive atmosphere.

Incorrect installation, operation or maintenance of the positioner in potentially explosive atmospheres may lead to ignition of the atmosphere and ultimately to death.

- ➔ The following regulations apply to installation in hazardous areas: EN 60079-14 (VDE 0165, Part 1).
- ➔ Installation, operation or maintenance of the positioner must only be performed by personnel who has undergone special training or instructions or who is authorized to work on explosion-protected devices in hazardous areas.

1.2 Notes on possible personal injury

⚠ WARNING

Risk of personal injury due to moving parts on the valve.

During initialization of the positioner and during operation, the valve moves through its entire travel range. Injury to hands or fingers is possible if they are inserted into the valve.

- During initialization, do not insert hands or fingers into the valve yoke and do not touch any moving valve parts.

Intrinsic safety rendered ineffective in intrinsically safe devices.

Every time the positioner is operated, even not within the plant (e.g. during maintenance, calibration and work on equipment), it must be ensured that the conditions for intrinsically safe circuits are observed.

- Only connect intrinsically safe devices intended for use in intrinsically safe circuits to certified intrinsically safe input-connected units.
- Do not place intrinsically safe devices back into operation that were connected to intrinsically safe input-connected units without certification.
- Do not exceed the maximum permissible electric values specified in the EC type examination certificates when interconnecting intrinsically safe electrical equipment (U_i or U_0 , I_i or I_0 , P_i or P_0 , C_i or C_0 and L_i or L_0).

Sudden loud noise when the pneumatic actuator vents.

The positioner mounted onto the control valve can cause the pneumatic actuator to vent. A loud noise may occur during venting. This can cause hearing damage.

- Wear hearing protection when working near the valve.

1.3 Notes on possible property damage

ⓘ NOTICE

Risk of damage to the positioner due to incorrect mounting position.

- Do not mount the positioner with the back of the device facing upward.
- Do not seal or restrict the vent opening when the device is installed on site.

An incorrect electric signal will damage the positioner.

A current source must be used to power the positioner.

- Only use a current source and never a voltage source.

Incorrect assignment of the terminals will damage the positioner and will lead to malfunction.

For the positioner to function properly, the prescribed terminal assignment must be observed.

- Connect the electrical wiring to the positioner according to the prescribed terminal assignment.

Malfunction due to initialization not yet completed.

The initialization causes the positioner to be calibrated to adapt it to the mounting situation. After initialization is completed, the positioner is ready for use.

- Initialize the positioner on first start-up.
- Re-initialize positioner after changing the mounting position.

Risk of positioner damage due to incorrect grounding of the electric welding equipment.

- Do not ground electric welding equipment near to the positioner.

1.4 Special instructions concerning explosion protection

If a part of the device on which the explosion protection is based needs to be serviced, the device must not be put back into operation until a qualified inspector has assessed it according to explosion protection requirements, has issued an inspection certificate, or given the device a mark of conformity. Inspection by a qualified inspector is not required if the manufacturer performs a routine test on the device before putting it back into operation and the passing of the routine test is documented by attaching a mark of conformity to the device. Replace explosion-protected components only with original, routine-tested components by the manufacturer.

Devices that have already been operated outside hazardous areas and are intended for future use inside hazardous areas must comply with the safety requirements placed on serviced devices. Before being operated inside hazardous areas, test the devices according to the specifications for servicing explosion-protected devices.

Safety instructions and measures

Maintenance, calibration and work on equipment

- Only use intrinsically safe current/voltage calibrators and measuring instruments for interconnection with intrinsically safe circuits to check or calibrate the equipment inside or outside hazardous areas.
- Observe the maximum permissible values specified in the certificates for intrinsically safe circuits.

Equipment with type of protection Ex nA

- In equipment operated with type of protection Ex nA (non-sparking equipment), only connect, isolate or switch circuits while energized during installation, maintenance or repair.
- Use certified cable glands and blanking plugs with appropriate type of protection and IP rating $\geq 6X$ and suitable for the certified temperature range.
- Connect the signal circuit using screw terminals (terminal 11/12) for electrical conductors with a wire cross-section from 0.2 to 2.5 mm². The tightening torque is 0.5 to 0.6 Nm.

Equipment with type of protection Ex t

- In equipment operated with type of protection Ex t (protection by enclosure), only connect, isolate or switch circuits while energized during installation, maintenance or repair.
- While working on the device during operation in potentially explosive dust atmospheres, be aware that opening the housing cover may cause the explosion protection to become ineffective.
- Use certified cable glands and blanking plugs with appropriate type of protection and IP rating $\geq 6X$ and suitable for the certified temperature range.
- To connect the signal circuit, use screw terminals (terminal 11/12) for electrical conductors with a wire cross-section from 0.2 to 2.5 mm². The tightening torque is 0.5 to 0.6 Nm.

1.5 Warnings on the device

Warning	Meaning of the warning
	<p>Warning against sudden loud noise The positioner mounted onto the control valve can cause the pneumatic actuator to vent. A loud noise may occur during venting. This can cause hearing damage.</p>

2 Markings on the device

2.1 Nameplate

Explosion-protected version

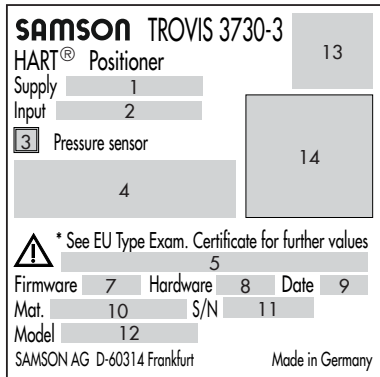

- 1 Supply pressure
- 2 Signal range
- 3 Pressure sensor (yes/no)
- 4 Type of protection for explosion-protected devices
- 5 Temperature ranges for explosion-protected devices
- 6 Code for NAMUR Recommendation NE 53 (internal specification)

Version without explosion protection

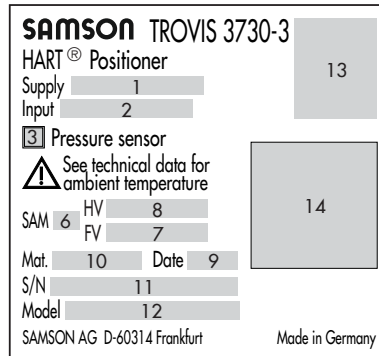

- 7 Firmware version
- 8 Hardware version
- 9 Date of manufacture
- 10 Material number
- 11 Serial number
- 12 Model number
- 13 Approvals (CE, EAC, UKCA etc.)
- 14 DataMatrix code (electronic nameplate)

2.2 Options

If option modules are installed in the TROVIS 3730-3 Positioner, a label to identify the module is affixed to the device:

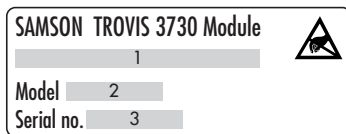

- 1 Option's function
- 2 Model number
- 3 Serial number

2.3 Firmware versions

Firmware revisions	
Old	New
2.00.11	2.00.13
	Initialization optimized
2.00.13	2.00.15
	Internal revisions

2.4 Article code

Positioner	TROVIS 3730-3- x x x 0 x x x x x 0 x x 0 x x x x x x x x x x x																			
With LCD, autotune, HART® communication																				
Explosion protection																				
Without	0	0	0																	
ATEX	II 2G Ex ia IIC T4/T6 Gb	1	1	0																
	II 2D Ex ia IIIC T85 °C Db	5	1	0															1	
	II 2D Ex tb IIIC T85 °C Db	8	1	0																1
	II 3G Ex ec IIC T4/T6 Gc	8	5	0																1
	II 2D Ex tb IIC T85 °C Db	8	5	0																1
IECEX	Ex ia IIC T4/T6 Gb	1	1	1																
	Ex ia IIIC T85 °C Db	5	1	1																1
	Ex tb IIIC T85 °C Db	8	1	1																1
	Ex ec IIC T4/T6 Dc	8	5	1																1
	Ex ec IIC T6 Gc	1	1	2																
CCC Ex	Ex ia IIC T4/T6 Gb	5	1	2																1
	Ex ia IIIC T85 °C Db	1	1	1																
CCoE	Ex ia IIC T4/T6 Gb	1	1	3																
EAC Ex	1Ex ia IIC T6...T4 Gb X	1	1	3																
	Ex ia IIIC T85 °C Db X																			

Markings on the device

Positioner	TROVIS 3730-3- x x x 0 x x x x x 0 x x 0 x x x x x x x x x x																			
Option C																				
Without	0																			
2x Software limit switches + binary output (PLC)	1																			
2x Software limit switches + binary output (NAMUR) ¹⁾	2																			
2x Inductive limit switches + Binary output (NAMUR); -50 to +85 °C	4																			
Option D																				
Without	0																			
External travel sensor with M12x1 connector; with 10 m connecting cable	1																			
Prepared for external travel sensor with M12x1 connector	2																			
Field barrier																				
Without	0																			
Prepared for Type 3770 Field Barrier	3																			
Emergency shutdown																				
3.8 mA																				
Electrical connection																				
2x M20x1.5 (1x cable gland, 1x blanking plug)																				
Housing material																				
Aluminum EN AC-44300DF (standard)																				
Stainless steel 1.4408																				
Cover																				
With round window																				
Without window																				
Housing version																				
Standard																				
With additional vent hole and VDI/VDE 3847 adapter; without travel pick-off parts																				
With additional vent hole																				
Safety approval																				
SIL																				

Positioner	TROVIS 3730-3- x x x 0 x x x x x 0 x x 0 x x x x x x x x x x				
Type approval for marine applications					
Without	0				
Bureau Veritas	1				
DNV GL	2				
American Bureau of Shipping (ABS)	3				
Lloyd's Register	5				
Permissible ambient temperature					
Standard: -20 to +85 °C	0				
-40 to +85 °C metal cable gland	1				
-55 to +85 °C, low-temperature version with metal cable gland	2				
Hardware version					
HV 01.00.00		9	9		
Firmware version					
SV 02.00.15				9	7

¹⁾ Only for versions with explosion protection

3 Design and principle of operation

→ See Fig. 3-1

The TROVIS 3730-3 Electropneumatic Positioner is mounted on pneumatic control valves and used to assign the valve position (controlled variable x) to the control signal (set point w). The positioner compares the electric control signal of a control system to the travel or opening angle of the control valve and issues a signal pressure for the pneumatic actuator.

The positioner mainly consists of a non-contact travel sensor system (2), pneumatics and the electronics with the microcontroller (4). The valve position is transmitted either as an angle of rotation or a travel to the pick-up lever, from there to the travel sensor (2) and forwarded to the microcontroller (4). The PID algorithm in the microcontroller compares the valve position measured by the travel sensor (2) to the 4 to 20 mA DC control signal issued by the control system after it has been converted by the A/D converter (3).

In case of a set point deviation, the activation of the i/p module (7) is changed so that the actuator of the control valve (1) is pressurized or vented accordingly over the downstream booster (6). As a result, the closure member of the valve (e.g. plug) is moved to the position determined by the set point.

The positioner is operated by a rotary push-button (10) for menu navigation on the plain-text display (11).

The extended EXPERTplus diagnostics are integrated into the positioner. They provide information on the control valve and positioner and generate diagnostic and status messages, which allow faults to be pinpointed quickly.

3.1 Additional equipment

Volume restriction

The volume restriction Q serves to adapt the air output capacity to the size of the actuator.

The volume restriction is a screw restriction which is screwed into the signal pressure output of the positioner (or output of the pressure gauge bracket or connecting plate).

- We recommend using a volume restriction
 - For linear actuators with a transit time < 1 s (e.g. with an actuator area smaller than 240 cm^2)
 - For rotary actuators with a volume of less than 300 cm^3
- Actuators with a transit time ≥ 1 s do not require the air flow rate to be restricted.

Design and principle of operation

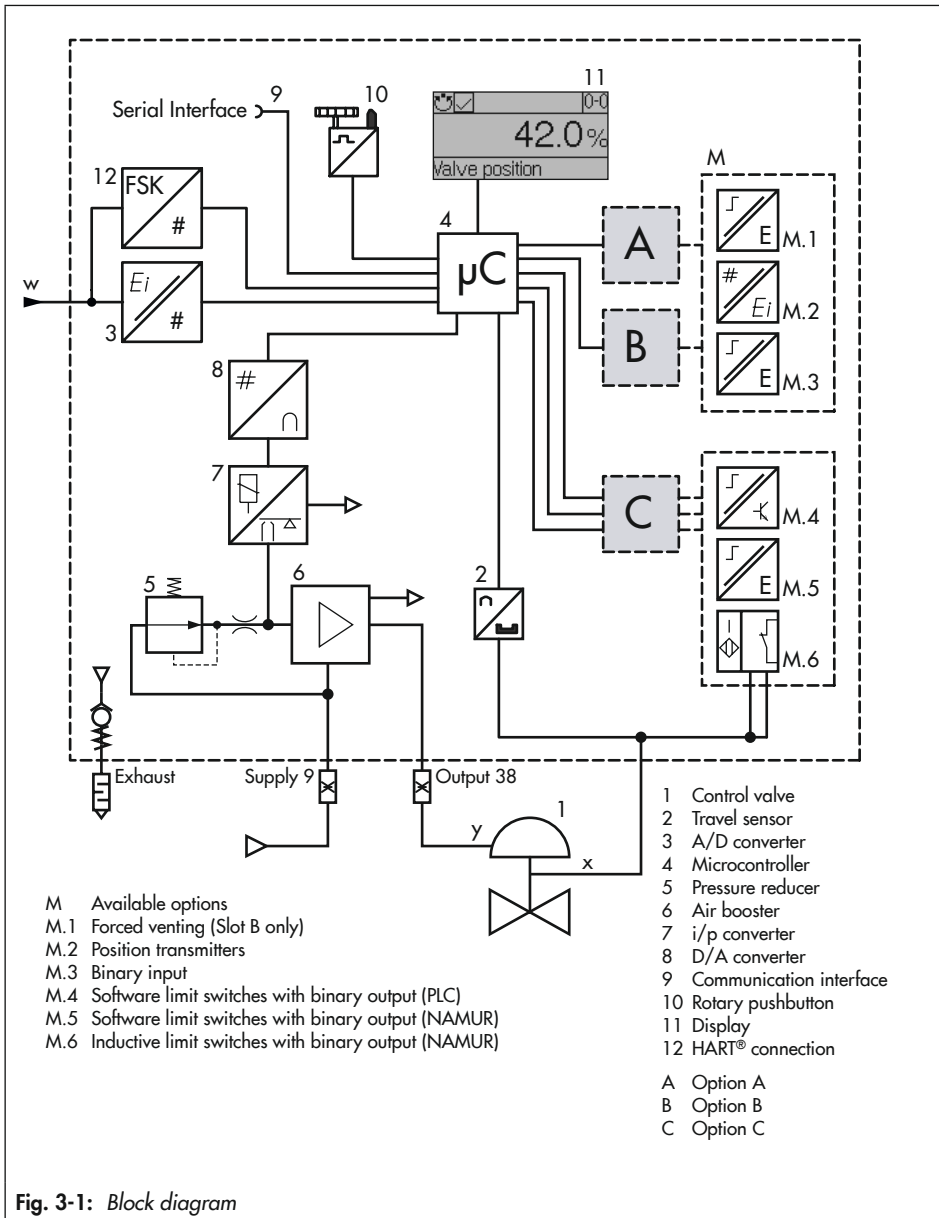

Fig. 3-1: Block diagram

3.1.1 Optional additional functions

i Note

Optional additional functions must be selected at the ordering stage and are ready installed in the delivered positioner. The options can only be exchanged or retrofitted by SAMSON's After-sales Service.

Inductive limit contacts

Inductive slot sensors issue a signal to a control system when the valve reaches one of the two adjustable limits. They are operated by adjustable tags. For operation of the inductive limit contacts, switching amplifiers must be connected in the output circuit.

Software limit contacts

The software limit contacts signalize that the valve has reached one of the two adjustable limits.

- When limit 1 is not reached
- When limit 2 is exceeded

The following versions are available:

- Connection of a PLC according to IEC 61131-2, $P_{\max} = 400 \text{ mW}$
- Connection to NAMUR switching amplifier acc. to EN 60947-5-6

Position transmitters

The position transmitter is a two-wire transmitter and issues the travel sensor signal as a 4 to 20 mA signal processed by the micro-controller. This signal is issued independent of the positioner's input signal. Additionally,

the position transmitter allows positioner faults to be indicated over a signal current of $<2.4 \text{ mA}$ or $>21.6 \text{ mA}$.

Forced venting

The positioner either vents the actuator or supplies it with air when the voltage signal at the terminals falls below 11 V. This occurs regardless of the set point. A voltage above 15 V keeps the forced venting function inactive.

Binary input

The binary input can be floating or non-floating (0 to 24 V) and can be configured to provide the following functions:

- **Switching state:** the switching state of the binary input is logged.
- **On-site write protection:** after the first initialization, a local write protection can be activated. While the binary input is active, no settings can be changed at the positioner. The positioner cannot be re-initialized.
- **PST (partial stroke test):** test to check the valve's ability to move and assess its dynamic control response (PST: partial stroke test/FST: full stroke test).
 - **Start PST:** perform a step response test in an adjustable range.
 - **Start FST:** perform a step response test over the entire travel range following configurable parameters).
- **Move valve to fixed value:** move the valve to a defined position (valve position in %).

Design and principle of operation

In addition, a binary input can be deactivated.

Binary output

A fault alarm output signalizes a fault to the control station. The following versions are available:

- Connection of a PLC according to IEC 61131-2, $P_{\max} = 400 \text{ mW}$
- Connection to NAMUR switching amplifier acc. to EN 60947-5-6

3.2 Mounting versions

The TROVIS 3730-3 Positioner is suitable for the following types of attachment using the corresponding accessories (see the 'Installation' chapter):

- Direct attachment to Type 3277 Actuator
The positioner is mounted on the yoke. The signal pressure is connected to the actuator over a connection block: internally over a hole in the valve yoke for "actuator stem extends" fail-safe action and through an external signal pressure line for "actuator stem retracts" fail-safe action.
- Attachment to actuators according to IEC 60534-6:
The positioner is attached to the control valve using a NAMUR bracket.
- Attachment according to VDI/VDE 3847-1/-2:
Attachment according to VDI/VDE 3847-1/-2 using the corresponding accessories allows the positioner to be replaced quickly while the process is running.
- Attachment to Type 3510 Micro-flow Valve
The positioner is attached to the valve yoke using a bracket.
- Attachment to rotary actuators according to VDI/VDE 3845:
The positioner is mounted to the rotary actuator using the corresponding accessories.

3.3 Configuration using the TROVIS-VIEW software

The positioner can be configured with SAMSON's TROVIS-VIEW Software (version 4). For this purpose, the positioner has a digital interface (**SSP**) to allow the USB port of a computer to be connected to it using an adapter cable.

The TROVIS-VIEW software enables the user to easily configure the positioner as well as view process parameters online.

i Note

TROVIS-VIEW provides a uniform user interface that allows users to configure and parameterize various SAMSON devices using device-specific database modules. The 3730-3 device module can be downloaded free of charge from our website at

▶ www.samsongroup.com > SERVICE & SUPPORT > Downloads > TROVIS-VIEW. Further information on TROVIS-VIEW (e.g. system requirements) is available on our website and in the Data Sheet ▶ T 6661 .

3.4 Technical data

Table 3-1: TROVIS 3730-3 Electropneumatic Positioner

Travel	
Adjustable travel for	Direct attachment to Type 3277: 3.6 to 30 mm Attachment according to IEC 60534-6 (NAMUR): 3.6 to 300 mm Attachment according to VDI/VDE 3847: 3.6 to 300 mm Attachment to rotary actuators: 24 to 100°
Travel range	Adjustable within the initialized travel/angle of rotation of the valve; travel can be restricted to 1/5 at the maximum.
Set point w	
Signal range	4 to 20 mA · Two-wire device, reverse polarity protection · Minimum span 4 mA
Static destruction limit	40 V, internal current limit approx. 40 mA
Minimum current	3.75 mA for display/operation (HART® communication and configuration) 3.90 mA for pneumatic function
Load impedance	≤ 9.3 V (corresponds to 465 Ω at 20 mA)
Supply air	
Supply air	1.4 to 7 bar (20 to 105 psi)
Air quality acc. to ISO 8573-1	Max. particle size and density: Class 4 Oil content: Class 3 Pressure dew point: Class 3 or at least 10 K below the lowest ambient temperature to be expected
Hysteresis	≤ 0.3 %
Sensitivity	≤ 0.1 %
Characteristic	Linear/Equal percentage/Reverse equal percentage/SAMSON butterfly valve
Transit time	Exhaust and supply adjustable separately up to 240 s by software
Direction of action	Reversible
Air consumption, steady state	Independent of supply air approx. 65 l _n /h
Air output capacity (when Δp = 6 bar)	
Actuator (supply)	8.5 m _n ³ /h · At Δp = 1.4 bar: 3.0 m _n ³ /h · K _{Vmax(20 °C)} = 0.09
Actuator (exhaust)	14.0 m _n ³ /h · At Δp = 1.4 bar: 4.5 m _n ³ /h · K _{Vmax(20 °C)} = 0.15

Environmental conditions and permissible temperatures	
Permissible environmental conditions according to EN 60721-3	
Storage	1K6 (relative humidity $\leq 95\%$)
Transport	2K4
Operation	-20 to +85 °C: All versions -40 to +85 °C: With metal cable glands -55 to +85 °C: Low-temperature version with metal cable glands Observe the limits in the test certificate for explosion-protected versions.
Resistance to vibration	
Vibrations (sinusoidal)	According to DIN EN 60068-2-6: 0.15 mm, 10 to 60 Hz; 20 m/s ² , 60 to 500 Hz per axis 0.75 mm, 10 to 60 Hz; 100 m/s ² , 60 to 500 Hz per axis
Bumps (half sine)	According to DIN EN 60068-2-29: 150 m/s ² , 6 ms; 4000 bumps per axis
Noise	According to DIN EN 60068-2-64: 10 to 200 Hz: 1 (m/s ²) ² /Hz 200 to 500 Hz: 0.3 (m/s ²) ² /Hz 4 h/axis
Recommended continuous duty	≤ 20 m/s ²
Influences	
Temperature	$\leq 0.15\%/10$ K
Auxiliary power	None
Requirements	
EMC	Complying with EN 61000-6-2, EN 61000-6-3, EN 61326-1 and NAMUR Recommendation NE 21
Degree of protection	IP 66/NEMA 4X
Electrical connections	
Cable glands	One M20x1.5 cable gland for 6 to 12 mm clamping range Second M20x1.5 threaded connection additionally available
Terminals	Screw terminals for 0.2 to 2.5 mm ² wire cross-section
Explosion protection	
ATEX, IECEx, ...	Refer to Table 3-3

Design and principle of operation

Materials	
Housing and cover	Die-cast aluminum EN AC-ALSi12(Fe) (EN AC-44300) acc. to DIN EN 1706, chromate and powder coating · Special version: stainless steel 1.4408
Window	Makrolon® 2807
Cable glands	Polyamide, nickel-plated brass, stainless steel 1.4305
Other external parts	Stainless steel: 1.4571 and 1.4301
Communication	
	TROVIS VIEW with SSP/HART® Revision 7
Weight	
	Aluminum housing: approx. 1.0 kg · Stainless steel housing: approx. 2.2 kg





Table 3-2: *Optional additional functions*

Position transmitters		
Version	Two-wire system, galvanic isolation, reverse polarity protection, reversible direction of action	
Auxiliary power	10 to 30 V DC	
Output signal	4 to 20 mA	
Error indication	2.4 or 21.6 mA	
No-load current	1.4 mA	
Static destruction limit	38 V DC · 30 V AC	
Software limit contacts	NAMUR	PLC
Version	Galvanic isolation, reverse polarity protection, switching output acc. to EN 60947-5-6	Galvanic isolation, reverse polarity protection, binary input of a PLC acc. to EN 61131-2, $P_{\max} = 400 \text{ mW}$
Signal state	$\leq 1.0 \text{ mA}$ (non-conducting)	$R = 10 \text{ k}\Omega$ (non-conducting)
	$\geq 2.2 \text{ mA}$ (conducting)	$R = 348 \Omega$ (conducting)
Static destruction limit	32 V DC/24 V AC	32 V DC/50 mA
Binary output	NAMUR	PLC
Version	Galvanic isolation, reverse polarity protection, switching output acc. to EN 60947-5-6	Galvanic isolation, reverse polarity protection, binary input of a PLC acc. to EN 61131-2, $P_{\max} = 400 \text{ mW}$
Signal state	$\leq 1.0 \text{ mA}$ (non-conducting)	$R = 10 \text{ k}\Omega$ (non-conducting)
	$\geq 2.2 \text{ mA}$ (conducting)	$R = 348 \Omega$ (conducting)
Static destruction limit	32 V DC/24 V AC	32 V DC/50 mA

Inductive limit contacts		
Version	For connection to switching amplifier according to EN 60947-5-6, SJ2-SN proximity switches, reverse polarity protection	
Measuring plate not detected	≥ 3 mA	
Measuring plate detected	≤ 1 mA	
Static destruction limit	20 V DC	
Perm. ambient temperature	-50 to +85 °C	
Binary input (switching behavior configured in TROVIS-VIEW software)		
Active switching behavior (default setting)		
Port	For external switch (floating contact) or relay contact	
Open-circuit voltage	Max. 10 V (when contact is open)	
Current draw	Max. 100 mA (pulsed when contact is closed)	
Contact	Closed: $R < 20 \Omega$; open: $R > 400 \Omega$	
Passive switching behavior		
Port	For externally applied DC voltage, reverse polarity protection	
Voltage input	0 to 30 V	
Static destruction limit	40 V DC	
Current draw	3.7 V at 24 mA	
Switching voltage	Closed: < 1 V; open: > 6 V	
Forced venting		
Version	Galvanic isolation, reverse polarity protection	
Voltage input	0 to 24 V DC	
Input resistance	≥ 7 k Ω	
Signal state	Active	$U_e < 11$ V
	Not active	$U_e > 15$ V
Static destruction limit	38 V DC/30 V AC	

Design and principle of operation

Table 3-3: Summary of explosion protection approvals

	Certification			Type of protection/ comments	
TROVIS 3730-3-	-110	 EU type examination certificate	Number Date	BVS 18 ATEX E 044 X 2023-05-11	II 2G Ex ia IIC T4/T6 Gb II 2D Ex ia IIIC T85 °C Db
	-510	 EU type examination certificate	Number Date	BVS 18 ATEX E 044 X 2023-05-11	II 2D Ex tb IIIC T85°C Db
	-810	 EU type examination certificate	Number Date	BVS 18 ATEX E 044 X 2023-05-11	II 3G Ex ec IIC T4/T6 Gc II 2D Ex tb IIC T85°C Db
	-850	 Statement of conformity	Number Date	BVS 18 ATEX E 045 2023-05-11	II 3G Ex ec IIC T4/T6 Gc
	-111	IECEX	Number Date	IECEX BVS 18.0035X 2023-05-26	Ex ia IIC T4/T6 Gb Ex ia IIIC T85°C Db
	-511	IECEX	Number Date	IECEX BVS 18.0035X 2023-05-26	Ex tb IIIC T85°C Db
	-811	IECEX	Number Date	IECEX BVS 18.0035X 2023-05-26	Ex tb IIIC T85°C Db Ex ec IIC T4/T6 Dc
	-851	IECEX	Number Date	IECEX BVS 18.0035X 2023-05-26	Ex ec IIC T6 Gc
	-112	CCC Ex	Number Date Valid until	2020322307001518 2023-04-29 2025-09-17	Ex ia IIC T4/T6 Gb Ex ia IIIC T85 °C Db
	-512	CCC Ex	Number Date Valid until	2020322307001518 2023-04-29 2025-09-17	Ex tb IIIC T85 °C Db
	-111	CCoE	Number Date Valid until	A/P/HQ/MH/104/8013 2023-12-31 2028-12-31	Ex ia IIC T4/T6 Gb
	-113	EAC Ex	Number Date Valid until	RU C-DE.HA65.B.00700/20 2020-08-19 2025-08-18	1Ex ia IIC T6...T4 Gb X Ex ia IIIC T85 °C Db X
		ECAS-Ex	On request		

		Certification		Type of protection/ comments
		Number	Date	
TROVIS 3730-3	-130	FM	Number FM21CA0064 Date 2022-10-18	IS Class I, II, III, Div. 1, Gr. A,B,C,D,E,F,G; T4/T6 Ex ia IIC T4/T6 Gb NI Class I, II, III Div. 2, Gr. A,B,C,D,F,G; T4/T6 Type 4X; IP66
	-130	FM	Number FM21US0097 Date 2022-10-18	IS Class I, II, III, Div. 1, Gr. A,B,C,D,E,F,G; T4/T6 IS Class I, Zone 1, AEx ia IIC T4/6 Gb NI Class I, II, III Div. 2, Gr. A,B,C,D,F,G; T4/T6 Type 4X; IP66
	-115	INMETRO	No. IEx 20.0090X/1 Date 2024-01-11 Valid until 2030-01-10	Ex ia IIC T4/T6 Gb Ex ia IIIC T85°C Db
	-515	INMETRO	No. IEx 20.0090X/1 Date 2024-01-11 Valid until 2030-01-10	Ex tb IIIC T85°C Db
	-815	INMETRO	No. IEx 20.0090X/1 Date 2024-01-11 Valid until 2030-01-10	Ex ec IIC T4/T6 Gc Ex tb IIIC T85°C Db
	-855	INMETRO	No. IEx 20.0090X/1 Date 2024-01-11 Valid until 2030-01-10	Ex ec IIC T4/T6 Gc
	-114	KCS Korea	Number 21-KA4BO-0920 Date 2021-12-06 Valid until 2024-12-06	Ex ia IIC T6/T4
	-112	NEPSI	Number GYJ23.1092X Date 2023-04-29 Valid until 2028-04-28	Ex ia IIC T4/T6 Gb Ex ia IIIC T85°C Db
	-512	NEPSI	Number GYJ23.1092X Date 2023-04-29 Valid until 2028-04-28	Ex tb IIIC T85°C Db

Design and principle of operation

		Certification		Type of protection/ comments
TROVIS 3730-3	-116	TR CMU 1055	Number ZETC/35/2021 Date 2021-07-26 Valid until 2024-07-25	II 2G Ex ia IIC T4/T6 Gb II 2D Ex ia IIIC T85 °C Db
	-516	TR CMU 1055	Number ZETC/35/2021 Date 2021-07-26 Valid until 2024-07-25	II 2D Ex Ib IIIC T85 °C Db
	-816	TR CMU 1055	Number ZETC/35/2021 Date 2021-07-26 Valid until 2024-07-25	II 3G Ex nA IIC T4/T6 Gc II 2D Ex Ib IIIC T85 °C Db
	-856	TR CMU 1055	Number ZETC/35/2021 Date 2021-07-26 Valid until 2024-07-25	II 3G Ex nA IIC T4/T6 Gc

3.5 Dimensions in mm

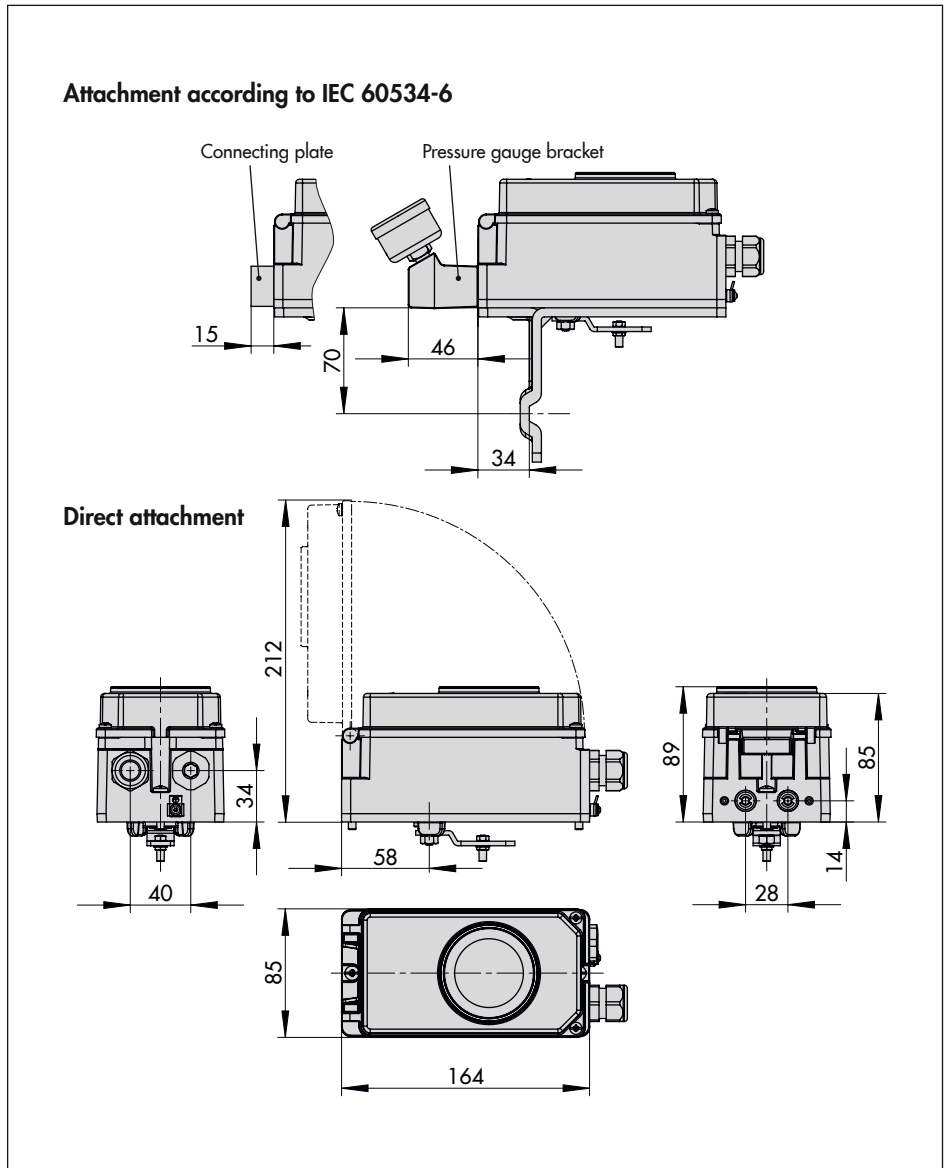

**Attachment according to VDI/
VDE 3847-1 onto Type 3277
Actuator**

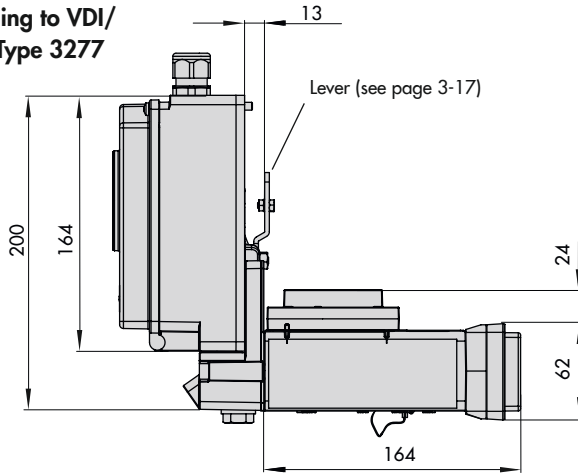

**Attachment according to VDI/
VDE 3847 to a NAMUR rib**

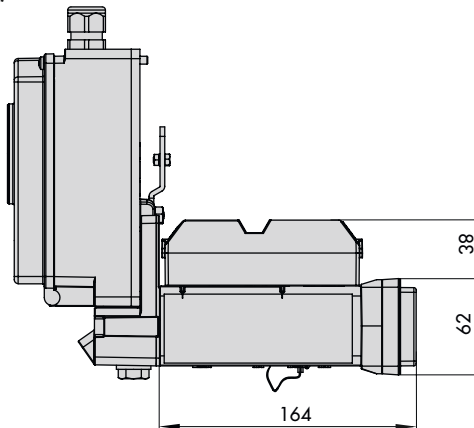

**Attachment according to VDI/VDE 3847-2
with single-acting actuator**

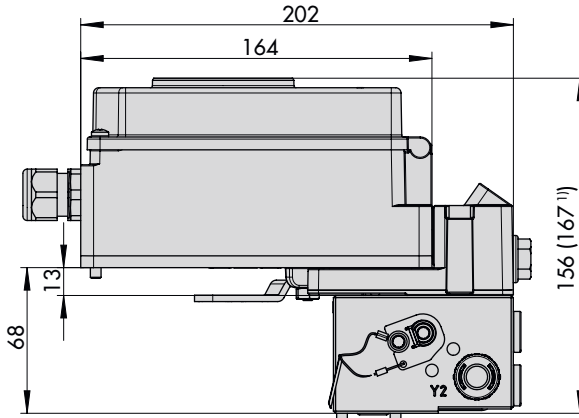

**Attachment according to VDI/VDE 3847-2
with double-acting actuator**

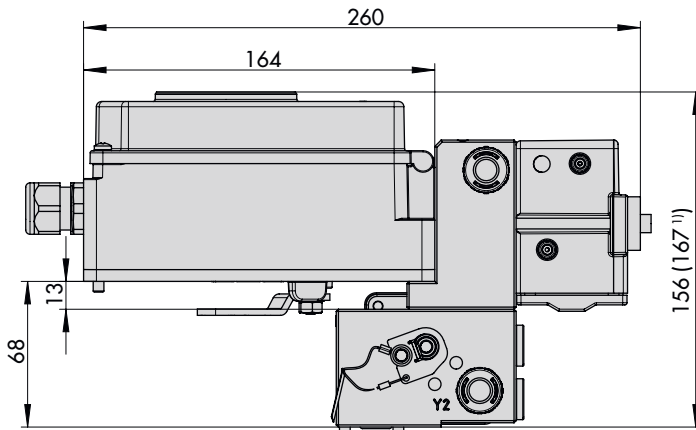

1) For attachment using intermediate plate

Attachment to rotary actuators according to VDI/VDE 3845

Heavy-duty version

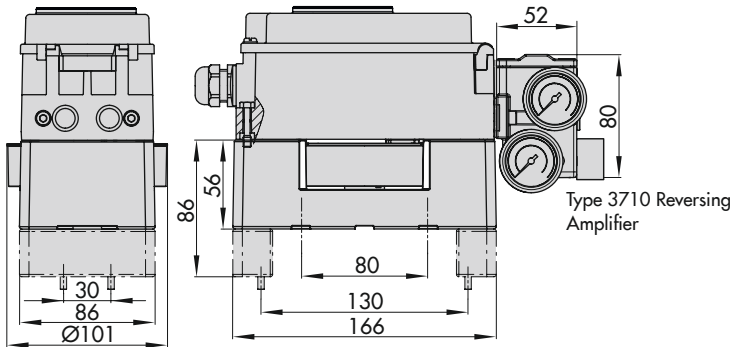

Light version

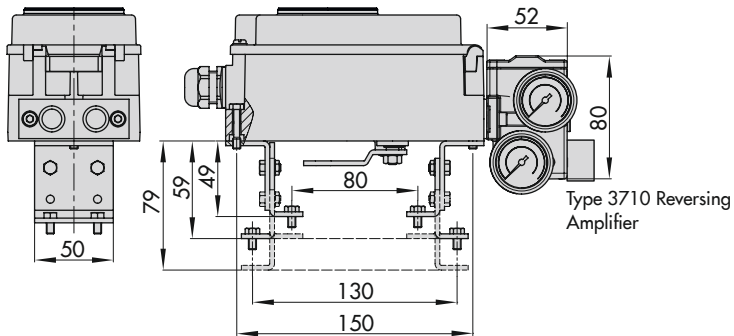

Lever

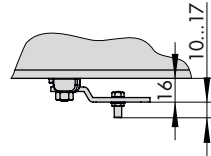
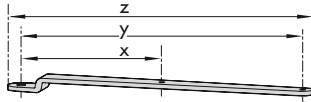

Lever	x	y	z
M	25 mm	50 mm	66 mm
L	70 mm	100 mm	116 mm
XL	100 mm	200 mm	216 mm
XXL	200 mm	300 mm	316 mm

3.6 Fixing levels according to VDI/VDE 3845 (September 2010)

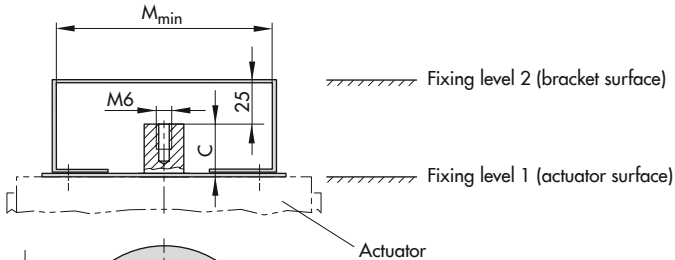

Dimensions in mm						
Size	A	B	C	Ød	M _{min}	D ¹⁾
AA0	50	25	15	5.5 for M5	66	50
AA1	80	30	20	5.5 for M5	96	50
AA2	80	30	30	5.5 for M5	96	50
AA3	130	30	30	5.5 for M5	146	50
AA4	130	30	50	5.5 for M5	146	50
AA5	200	50	80	6.5 for M6	220	50

¹⁾ Flange type F05 acc. to DIN EN ISO 5211

4 Shipment and on-site transport

The work described in this chapter is only to be performed by personnel appropriately qualified to carry out such tasks.

4.1 Accepting the delivered goods

After receiving the shipment, proceed as follows:

1. Check the scope of delivery. Check that the specifications on the nameplate of the positioner match the specifications in the delivery note. See the 'Markings on the device' chapter for nameplate details.
2. Check the shipment for transportation damage. Report any damage to SAMSON and the forwarding agent (refer to delivery note).

4.2 Removing the packaging from the positioner

Observe the following sequence:

- ➔ Do not remove the packaging until immediately before installing the positioner, pneumatic and option modules.
- ➔ Dispose and recycle the packaging in accordance with the local regulations.

4.3 Transporting the positioner

- ➔ Pack the positioner properly to comply with terms of transportation.

Transport instructions

- Protect the positioner against external influences (e.g. impact).
- Protect the positioner against moisture and dirt.
- Observe transport temperature depending on the permissible ambient temperature (see the 'Design and principle of operation' chapter).

4.4 Storing the positioner

NOTICE

Risk of positioner damage due to improper storage.

- ➔ *Observe the storage instructions.*
 - ➔ *Avoid long storage times.*
 - ➔ *Contact SAMSON in case of different storage conditions or longer storage times.*
-

Storage instructions

- Protect the positioner against external influences (e.g. impact, shocks, vibration).
- Do not damage the corrosion protection (coating).
- Protect the positioner against moisture and dirt. In damp spaces, prevent condensation. If necessary, use a drying agent or heating.

Shipment and on-site transport

- Observe storage temperature depending on the permissible ambient temperature (see the 'Design and principle of operation' chapter).
- Store the positioner with the cover closed.
- Seal the pneumatic and electrical connections.

5 Installation

The work described in this chapter is only to be performed by personnel appropriately qualified to carry out such tasks.

⚠ DANGER

Risk of fatal injury due to the ignition of an explosive atmosphere.

- Observe EN 60079-14 (VDE 0165, Part 1) for work on the positioner in potentially explosive atmospheres.
- Work in potentially explosive atmospheres must only be performed by personnel who has undergone special training or instructions or who is authorized to work on explosion-protected devices in hazardous areas.

⚠ WARNING

Crush hazard arising from moving parts on the valve.

- Do not touch any moving valve parts while the control valve is in operation.
- Before performing any mounting or installation work on the positioner, put the control valve out of operation by disconnecting and locking the supply air and control signal.
- Do not impede the movement of the actuator and plug stem by inserting objects into the yoke.

📢 NOTICE

Risk of malfunction due to incorrect mounting parts/accessories.

- Only use the mounting parts and accessories listed in these mounting and operating instructions to mount and install the positioner. Pay special attention to the type of attachment.

5.1 Installation conditions

Work position

The work position for the positioner is the front view onto the operating controls on the positioner seen from the position of operating personnel.

Operators must ensure that, after installation of the positioner, the operating personnel can perform all necessary work safely and easily access the device from the work position.

Mounting orientation

- Do not seal or restrict the vent opening (see Fig. 5-1) when the device is installed on site.
- Observe mounting position (see Fig. 5-2).

5.2 Preparation for installation

Before mounting, make sure the following conditions are met:

- The positioner is not damaged.
- The air supply is not yet connected to the positioner.
- The current is not yet connected to the positioner.

Proceed as follows:

- Lay out the necessary material and tools to have them ready during mounting.
- Adjust correct lever and pin position (see Chapter 5.4).
- Remove the protective caps from the pneumatic connections.

5.3 Turning the positioner shaft

To turn or hold the positioner shaft in position, turn or hold the actual shaft lock by hand.

- Do not use the locking screw to turn the positioner shaft knob. Only turn the rotary knob by hand (see Fig. 5-5).

5.4 Adjusting the lever and pin position

i Note

The **M** lever is included in the scope of delivery.

S, **L**, **XL** levers are available as accessories (see Table 5-7). The **XXL** lever is available on request.

The positioner is adapted to the actuator and to the rated travel by the lever on the back of the positioner and the pin inserted into the lever.

The travel tables on page 5-4 show the maximum adjustment range at the positioner. The travel that can be implemented at the valve is additionally restricted by the selected fail-safe position and the required compression of the actuator springs.

The positioner is equipped with the **M** lever (pin position 35) as standard (see Fig. 5-3).

If a pin position other than position **35** with the standard **M** lever is required or an **L** or **XL** lever size is required, proceed as follows (see Fig. 5-4):

1. Fasten the follower pin (2) in the assigned lever hole (pin position as specified in the travel tables on page 5-4). Only use the longer follower pin included in the mounting kit.
2. Place the lever (1) on the shaft of the positioner and fasten it tight using the disk spring (1.2) and nut (1.1).

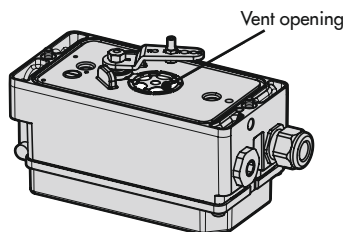

Fig. 5-1: Vent opening
(back of the positioner)

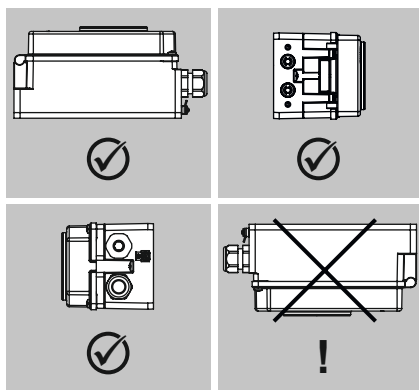
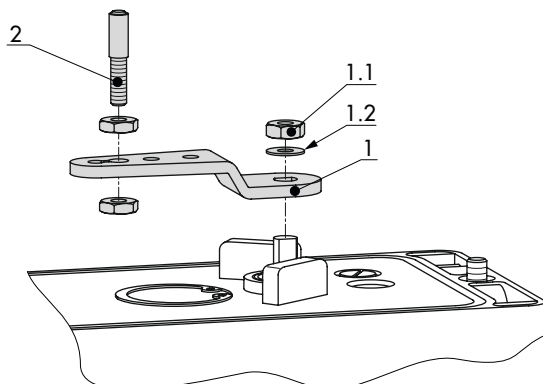
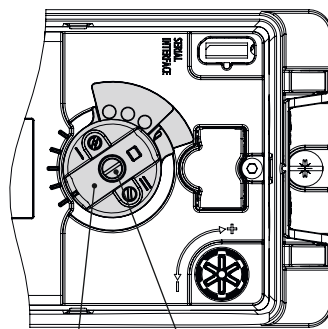

Fig. 5-2: Permissible mounting
positions



- 1 Lever
- 1.1 Nut
- 1.2 Disk spring
- 2 Follower pin

Fig. 5-4: Mounting the lever
and follower pin



- Rotary knob
- Locking screw

Fig. 5-5: Shaft lock

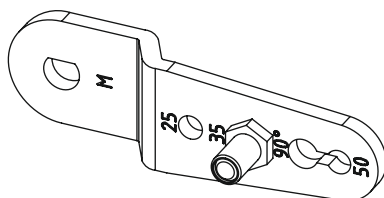

Fig. 5-3: M lever with pin position 35

5.4.1 Travel tables

i Note

The **M** lever is included in the scope of delivery.

S, L, XL levers for attachment according to IEC 60534-6 (NAMUR) are available as accessories (see Table 5-7 on page 5-51). The **XXL** lever is available on request.

Table 5-1: Direct attachment to Type 3277-5 and Type 3277 Actuator

Actuator size [cm ²]	Rated travel [mm]	Adjustment range at positioner Travel [mm]	Required lever	Assigned pin position
120	7.5	5.0 to 25.0	M	25
120/175/ 240/350	15	7.0 to 35.0	M	35
355/700/750	30	10.0 to 50.0	M	50

Table 5-2: Attachment according to IEC 60534-6 (NAMUR)

SAMSON valves with Type 3271 Actuator		Adjustment range at positioner Other control valves		Required lever	Assigned pin position
Actuator size [cm ²]	Rated travel [mm]	Min. travel [mm]	Max. travel [mm]		
120 with Type 3510 Valve	7.5	3.5	17.5	S	17
120	7.5	5.0	25.0	M	25
120/175/240/350	15	7.0	35.0	M	35
700/750	7.5	7.0	35.0	M	35
355/700/750	15 and 30	10.0	50.0	M	50
1000/1400/2800	30	14.0	70.0	L	70
	60	20.0	100.0	L	100
1400/2800	120	40.0	200.0	XL	200
1400	250	60.0	300.0	XXL	300

Table 5-3: Attachment to rotary actuators

Opening angle	Required lever	Assigned pin position
24 to 100°	M	90°

5.5 Installing a volume restriction

We recommend using a volume restriction

- For linear actuators with a transit time < 1 s (e.g. with an actuator area smaller than 240 cm^2)
- For rotary actuators with a volume of less than 300 cm^3

Volume restriction in the connection block (direct attachment). See Fig. 5-6.

→ Order no. 100041955

1. Apply a thin film of lubricant to the O-ring at the signal pressure output.
2. Carefully push and turn the volume restriction (1) (e.g. using a hex wrench) into the opening (tube) of the signal pressure output at the connection block as far as it will go.
3. Place the connection block (2) against the positioner and the actuator yoke and fasten using the screw.

Volume restriction on the connecting plate/pressure gauge bracket (see Fig. 5-7)

→ Order no. 100041162

1. Insert the volume restriction (1) with O-ring at the signal pressure output of the connecting plate (3)/pressure gauge bracket in place of the existing O-ring.
2. Place the connecting plate (3)/pressure gauge bracket on the positioner and fasten using screws and spring washers.

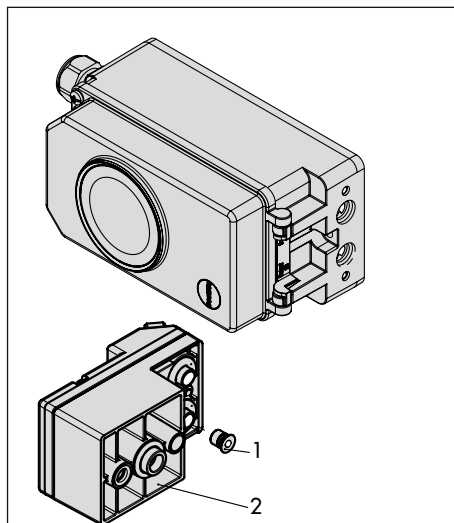

Fig. 5-6: Installing the volume restriction (1) in the connection block (2)

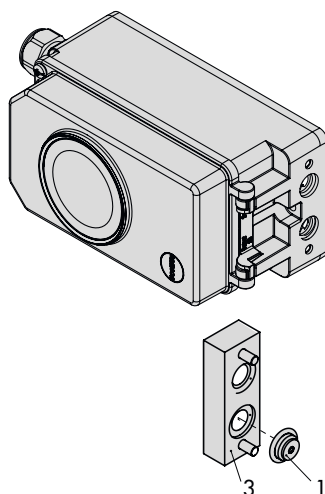

Fig. 5-7: Installing the volume restriction (1) in the connecting plate (3)

5.6 Positioner attachment

i Note

We recommend using a volume restriction for a transit time < 1 s (see Chapter 5.5).

5.6.1 Direct attachment

a) Type 3277-5 Actuator

- Actuator with 120 cm² (see Fig. 5-8)
 - Required mounting parts and accessories: Table 5-5 on page 5-49.
 - Observe travel tables on page 5-4.
 - Depending on the fail-safe action of the actuator "actuator stem extends" or "actuator stem retracts", mount the switchover plate (9) on the actuator yoke. Align the symbol for attachment to the left or right side with the marking (see Fig. 5-8, top).
1. Mount connecting plate (6) or pressure gauge bracket (7) with pressure gauges on the positioner. Make sure that the two seals (6.1) are seated properly.
 2. Remove screw plug (4) on the back of the positioner and seal the signal pressure output (38) on the connecting plate (6) or on the pressure gauge bracket (7) with the stopper (5) included in the accessories.
 3. Place follower clamp (3) on the actuator stem, align it and screw tight so that the mounting screw is located in the groove of the actuator stem.
 4. Mount cover plate (10) with narrow side of the cut-out (Fig. 5-8, on the left) pointing towards the signal pressure connection. Make sure that the gasket (14) points towards the actuator yoke.
 5. Check the pin position of the follower pin (2) on M lever (1). Refer to travel tables for type of attachment. If necessary, change the pin position (see Chapter 5.4).
 6. Insert molded seal (15) into the groove of the positioner housing and insert the seal (10.1) on the back of the housing.
 7. Place positioner on the cover plate (10) in such a manner that the follower pin (2) rests on the top of the follower clamp (3). Adjust the lever (1) correspondingly and open the positioner cover to hold the positioner shaft in position at the shaft lock (Fig. 5-5). The lever (1) must rest on the follower clamp with spring force. Fasten the positioner on the cover plate (10) using the two fastening screws.
 8. Mount cover (11) on the other side. Make sure that the vent plug is located at the bottom when the control valve is installed to allow any condensed water that collects to drain off.

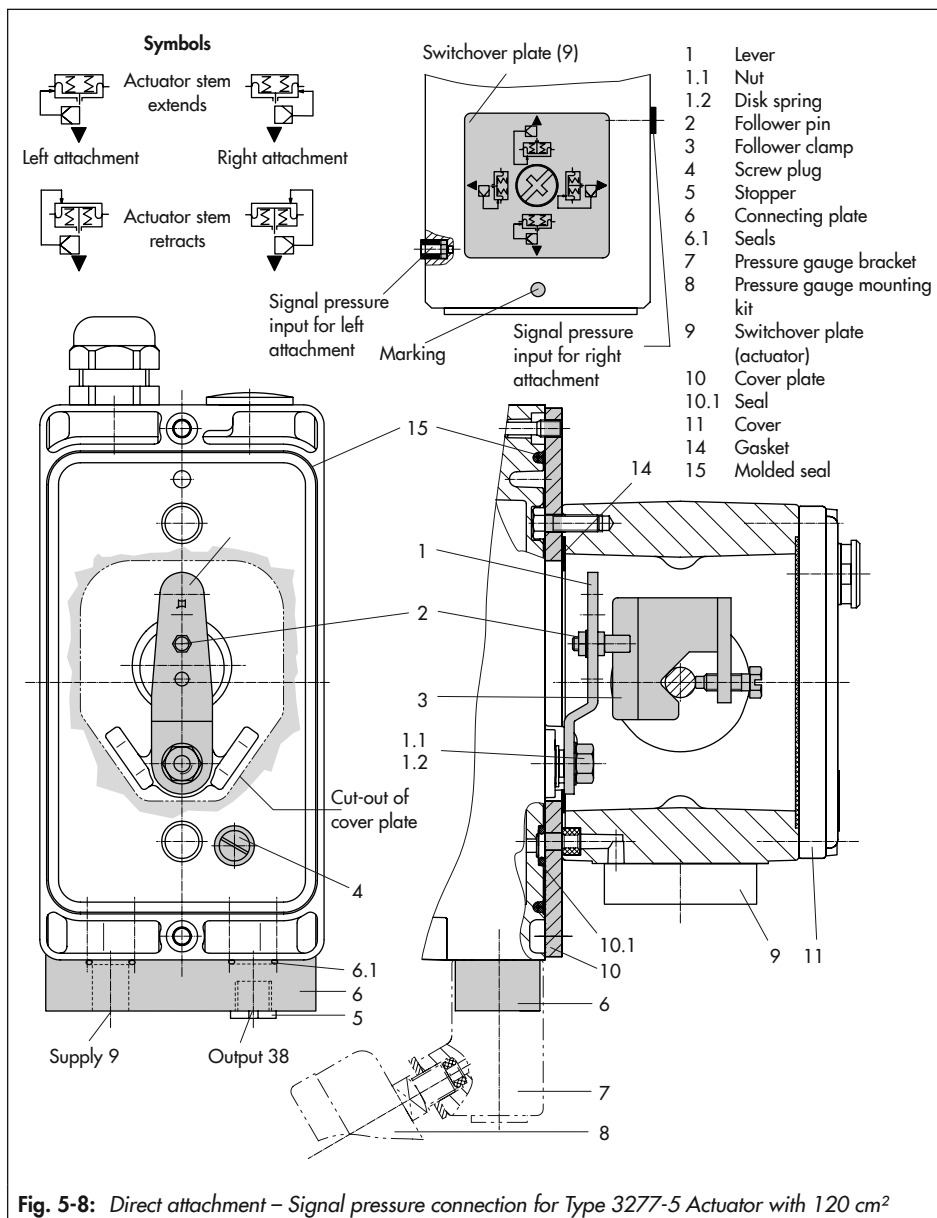

b) Type 3277 Actuator

- ➔ Actuators with 175 to 750 cm² (Fig. 5-9)
- ➔ Required mounting parts and accessories: Table 5-6 on page 5-50.
- ➔ Observe travel tables on page 5-4.

1. Seal the signal pressure output at the back of the positioner with the screw plug (4, order no. 0180-1254) and the associated O-ring (order no. 0520-0412) if the screw plug is not yet in place.
2. Place follower clamp (3) on the actuator stem, align it and screw tight so that the mounting screw is located in the groove of the actuator stem.
3. Mount cover plate (10) with narrow side of the cut-out (Fig. 5-9, on the left) pointing towards the signal pressure connection. Make sure that the gasket (14) points towards the actuator yoke.
4. Check the pin position of the follower pin (2) on M lever (1). Refer to travel tables for type of attachment. If necessary, change the pin position (see Chapter 5.4).
5. Insert molded seal (15) into the groove of the positioner housing.
6. Place positioner on the cover plate in such a manner that the follower pin (2) rests on the top of the follower clamp (3). Adjust the lever (1) correspondingly and open the positioner cover to hold the positioner shaft in position at the shaft lock (Fig. 5-5). The lever (1) must rest on the follower clamp with spring force.

Fasten the positioner on the cover plate (10) using the two fastening screws.

7. Make sure that the tip of the gasket (16) projecting from the side of the connection block is positioned to match the actuator symbol for the actuator's fail-safe action "actuator stem extends" or "actuator stem retracts". If this is not the case, unscrew the three fastening screws and lift off the cover. Turn the gasket (16) by 180° and re-insert it.
8. Place the connection block (12) with the associated seals against the positioner and the actuator yoke and fasten using the screw (12.1). For actuators with fail-safe action "actuator stem retracts", additionally remove the stopper (12.2) and mount the external signal pressure pipe.
9. Mount cover (11) on the other side. Make sure that the vent plug is located at the bottom when the control valve is installed to allow any condensed water that collects to drain off.

5.6.2 Attachment according to IEC 60534-6

- ➔ Required mounting parts and accessories: Table 5-7 on page 5-51.
- ➔ Observe travel tables on page 5-4.
- ➔ See Fig. 5-10

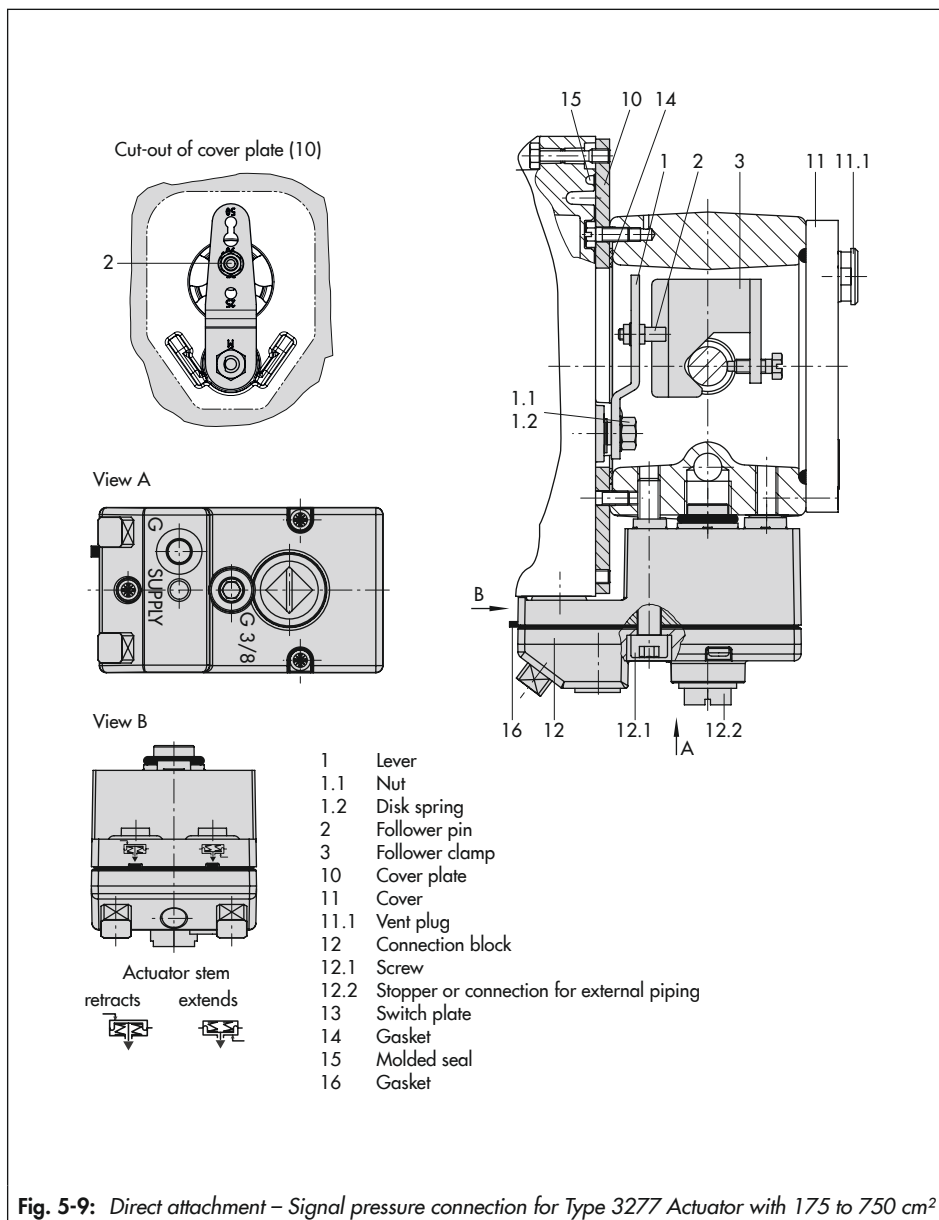

Installation

The positioner is attached to the control valve using a NAMUR bracket (10).

1. Seal the signal pressure output at the back of the positioner with the screw plug (4, order no. 0180-1254) and the associated O-ring (order no. 0520-0412) if the screw plug is not yet in place.
2. Screw the two bolts (14) to the bracket (9.1) of the stem connector (9), place the follower plate (3) on top and use the screws (14.1) for fastening.

Actuator sizes 2800 cm² and 1400 cm² with 120 mm travel:

- For a travel of 60 mm or smaller, screw the longer follower plate (3.1) directly to the stem connector (9).
 - For a travel exceeding 60 mm, mount the bracket (16) first and then the follower plate (3) to the bracket together with the bolts (14) and screws (14.1).
3. Mount NAMUR bracket (10) to the control valve as follows:
 - For **attachment to the NAMUR rib**, use an M8 screw (11) and toothed lock washer directly in the yoke hole.
 - For attachment to **valves with rod-type yokes**, use two U-bolts (15) around the yoke. Align the NAMUR bracket (10) according to the embossed scale so that the follower plate (3) is shifted by half the angle range to the NAMUR bracket (the slot of the follower plate is centrally aligned with the NAMUR bracket at mid valve travel).

4. Mount connecting plate (6) or pressure gauge bracket (7) with pressure gauges (8) on the positioner. Make sure that the two seals (6.1) are seated properly.
5. Select required lever size (1) M, L or XL and pin position according to the actuator size and valve travel listed in the travel table on page 5-4.

Should a pin position other than position **35** with the standard **M** lever be required or an **L** or **XL** lever size be required, proceed as follows:

6. Fasten the follower pin (2) in the assigned lever hole (pin position as specified in the travel table). Only use the longer follower pin (2) included in the mounting kit.
7. Place the lever (1) on the shaft of the positioner and fasten it tight using the disk spring (1.2) and nut (1.1). Move lever once all the way as far as it will go in both directions.
8. Place positioner on the NAMUR bracket in such a manner that the follower pin (2) rests in the slot of the follower plate (3, 3.1). Adjust the lever (1) correspondingly.
Screw the positioner to the NAMUR bracket using its two fastening screws.

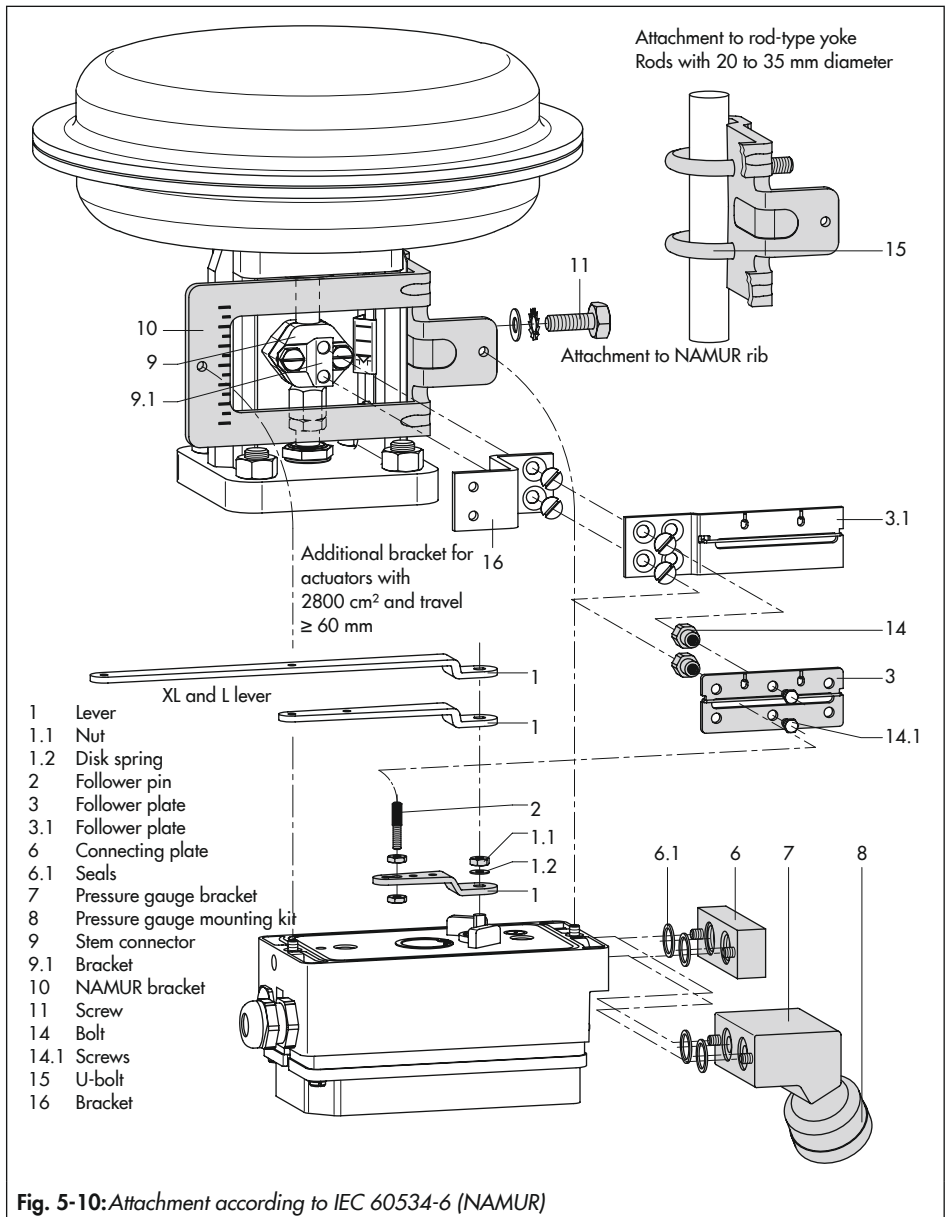

5.6.3 Attachment to Type 3510 Micro-flow Valve

→ See Fig. 5-11

→ Required mounting parts and accessories: Table 5-7 on page 5-51.

→ Observe travel tables on page 5-4.

The positioner is attached to the valve yoke using a bracket.

1. Seal the signal pressure output at the back of the positioner with the screw plug (4, order no. 0180-1254) and the associated O-ring (order no. 0520-0412) if the screw plug is not yet in place.
2. Fasten the bracket (9.1) to the stem connector.
3. Screw the two bolts (9.2) to the bracket (9.1) of the stem connector (9), place the follower plate (3) on top and use the screws (9.3) for fastening.
4. Mount the travel indication scale (accessories) to the outer side of the yoke using the hex screws (12.1), ensuring that the scale is aligned with the stem connector.
5. Fasten the hex bar (11) onto the outer side of yoke by screwing the M8 screws (11.1) directly into the holes on the yoke.
6. Fasten the bracket (10) to the hex bar (11) using the hex screw (10.1), shim and tooth lock washer.
7. Mount connecting plate (6) or pressure gauge bracket (7) with pressure gauges

on the positioner. Make sure that the two seals (6.1) are seated properly.

8. Unscrew the standard M lever (1) including follower pin (2) from the positioner shaft.
9. Take the S lever (1) and screw the follower pin (2) in the hole for pin position 17.
10. Place the S lever on the positioner shaft and screw tight using the disk spring (1.2) and nut (1.1).
Move lever once all the way as far as it will go in both directions.
11. Place positioner on the bracket (10) in such a manner that the follower pin slides into the groove of the follower pin (3). Adjust the lever (1) correspondingly. Screw the positioner to the bracket (10) using both its screws.

5.6.4 Attachment according to VDI/VDE 3847-1

→ See Fig. 5-12.

This type of attachment allows the positioner to be replaced quickly while the process is running by blocking the air in the actuator.

The signal pressure can be blocked in the actuator by unscrewing the red retaining screw (20) and turning the air blocker (19) on the bottom of the adapter block.

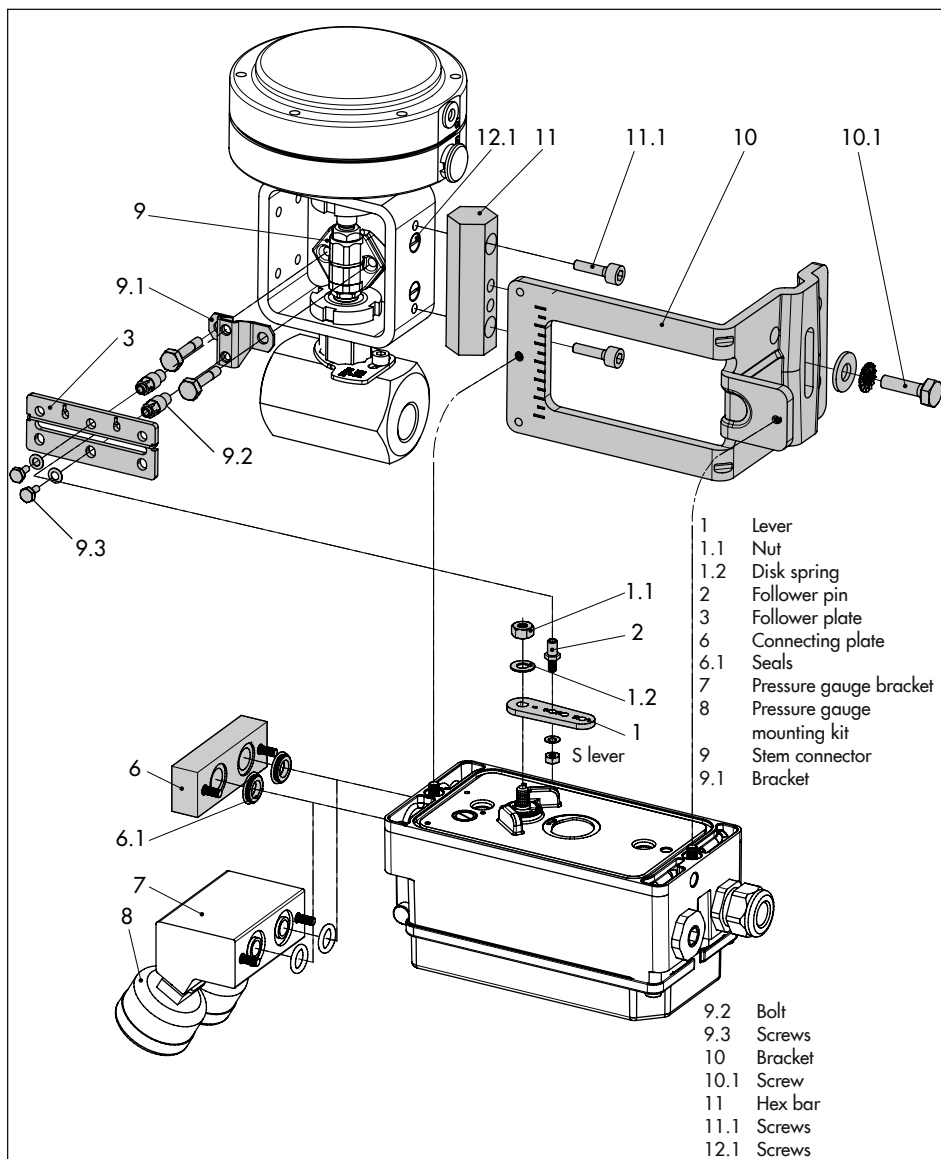

Fig. 5-11: Attachment to Type 3510 Micro-flow Valve

Attachment to Type 3277 Actuator (see Fig. 5-12)

➔ Required mounting parts and accessories: Table 5-8 on page 5-51.

Mount the positioner on the yoke as shown in Fig. 5-12. The signal pressure is routed to the actuator over the connecting plate (12), for actuators with fail-safe action "actuator stem extends" internally through a bore in the valve yoke and for "actuator stem retracts" through external piping.

Only the Y1 port is required for positioner attachment. The Y2 port can be used for air purging of the spring chamber.

1. Seal the signal pressure output at the back of the positioner with the screw plug (4, order no. 0180-1254) and the associated O-ring (order no. 0520-0412) if the screw plug is not yet in place.
2. Place follower clamp (3) on the actuator stem, align it and screw tight so that the mounting screw is located in the groove of the actuator stem.
3. Place the adapter bracket (6) on the positioner and mount using the screws (6.1). Make sure that the seals are correctly seated. For positioners **with air purging**, remove the stopper (5) before mounting the positioner. For positioners **without air purging**, replace the screw plug (4) with a vent plug.
4. For actuators with 355, 700 or 750 cm², remove the follower pin (2) on the M lever (1) on the back of the positioner from

pin position 35, reposition it in the hole for pin position 50 and screw tight.

For actuators 175, 240 and 350 cm² with 15 mm travel, keep the follower pin (2) in pin position 35.

5. Insert the molded seal (6.2) in the groove of the adapter bracket (6).
6. Insert the molded seal (17.1) into the turnboard (17) and mount the turnboard to the adapter block (13) using the screws (17.2).
7. Mount the blank plate (18) to the turnboard (17) using the screws (18.1). Make sure that the seals are correctly seated.

i Note

A solenoid valve can also be mounted in place of the blank plate (18). The orientation of the turnboard (17) determines the mounting position of the solenoid valve. Alternatively, a restrictor plate can be mounted (► AB 11).

8. Insert the screws (13.1) through the middle holes of the adapter block (13).
9. Place the connecting plate (12) together with the seal (12.1) onto the screws (13.1) corresponding to the fail-safe action "actuator stem extends" or "actuator stem retracts". The fail-safe action that applies is determined by aligning the groove of the adapter block (13) with the groove of the connecting plate (12) (Fig. 5-13).

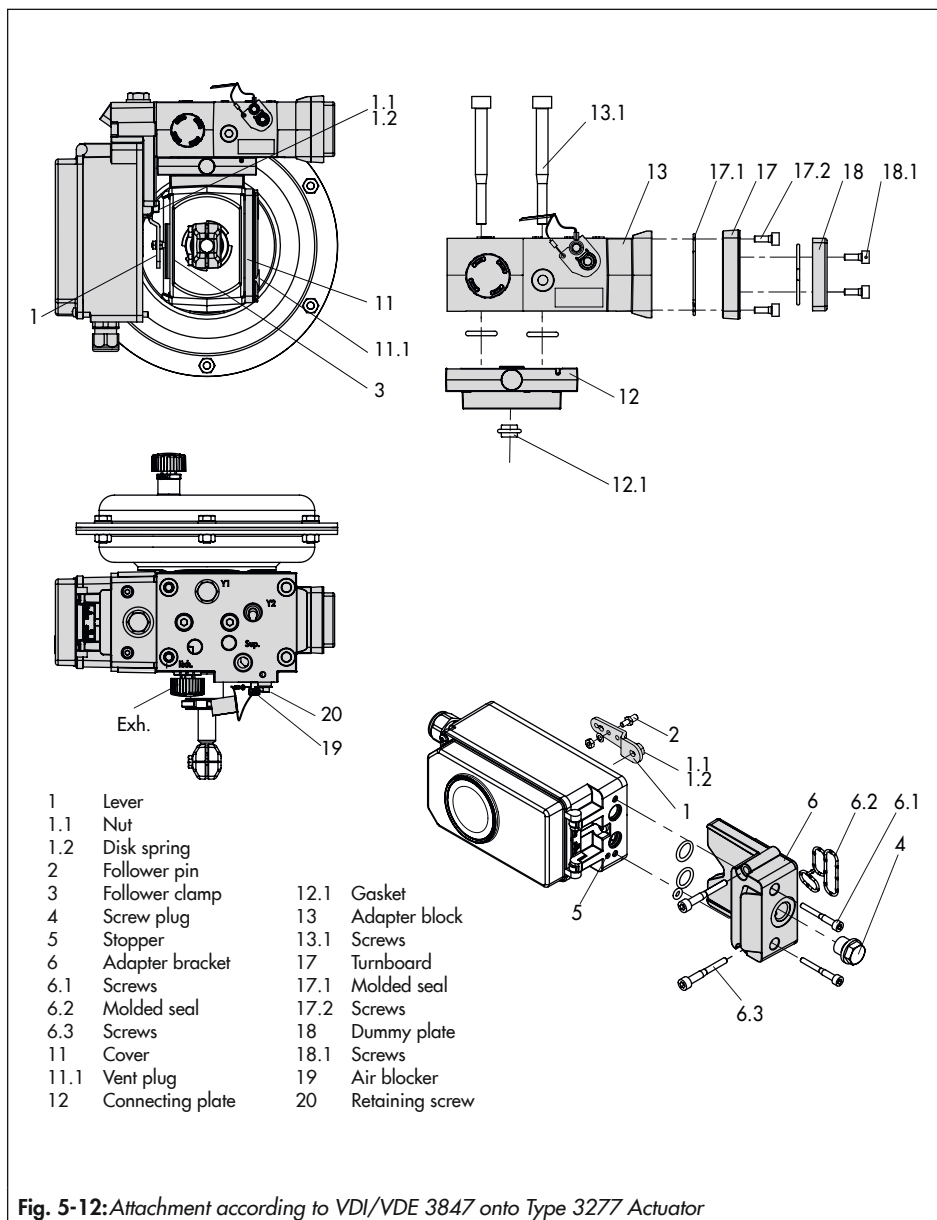
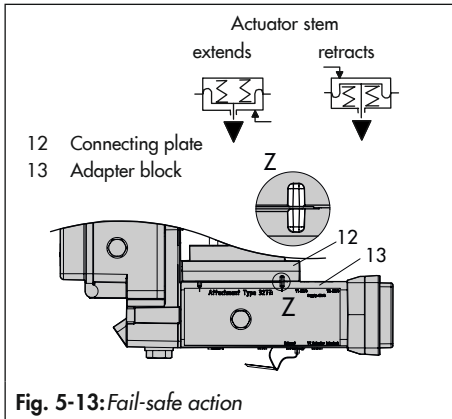

Fig. 5-12: Attachment according to VDI/VDE 3847 onto Type 3277 Actuator



10. Mount the adapter block (13) together with the connecting plate (12) to the actuator using the screws (13.1).
11. Insert the vent plug (11.1) into the **Exh.** connection.
12. For fail-safe action "actuator stem extends", seal the Y1 port with a blanking plug.
For fail-safe action "actuator stem retracts", connect the Y1 port to the signal pressure connection of the actuator.
13. Place positioner on the adapter block (13) in such a manner that the follower pin (2) rests on the top of the follower clamp (3). Adjust the lever (1) correspondingly and open the positioner cover to hold the positioner shaft in position at the shaft lock (Fig. 5-5). The lever (1) must rest on the follower clamp with spring force.
14. Fasten the positioner to the adapter block (13) using the two fastening screws (6.3).

Make sure the molded seal (6.2) is properly seated.

15. Mount cover (11) on the other side to the yoke. Make sure that the vent plug is located at the bottom when the control valve is installed to allow any condensed water that collects to drain off.

Attachment according to VDI/VDE 3847 to a NAMUR rib (see Fig. 5-14)

- Required mounting parts and accessories: Table 5-8 on page 5-51.
- Observe travel tables on page 5-4.

1. **Series 240 Valves, actuator size up to 1400-60 cm²:** Screw the two bolts (14) to the bracket of the stem connector or directly to the stem connector (depending on the version), place the follower plate (3) on top and use the screws (14.1) to fasten it.

Type 3251 Valve, 350 to 2800 cm²: Screw the longer follower plate (3.1) to the bracket of the stem connector or directly to the stem connector (depending on the version).

Type 3254 Valve, 1400-120 to 2800 cm²: Screw the two bolts (14) to the bracket (16). Fasten the bracket (16) on to the stem connector, place the follower plate (3) on top and use the screws (14.1) to fasten it.

Mount the positioner on the NAMUR rib as shown in Fig. 5-14.

2. For **attachment to the NAMUR rib**, fasten the NAMUR connection block (10) directly into the existing yoke bore using

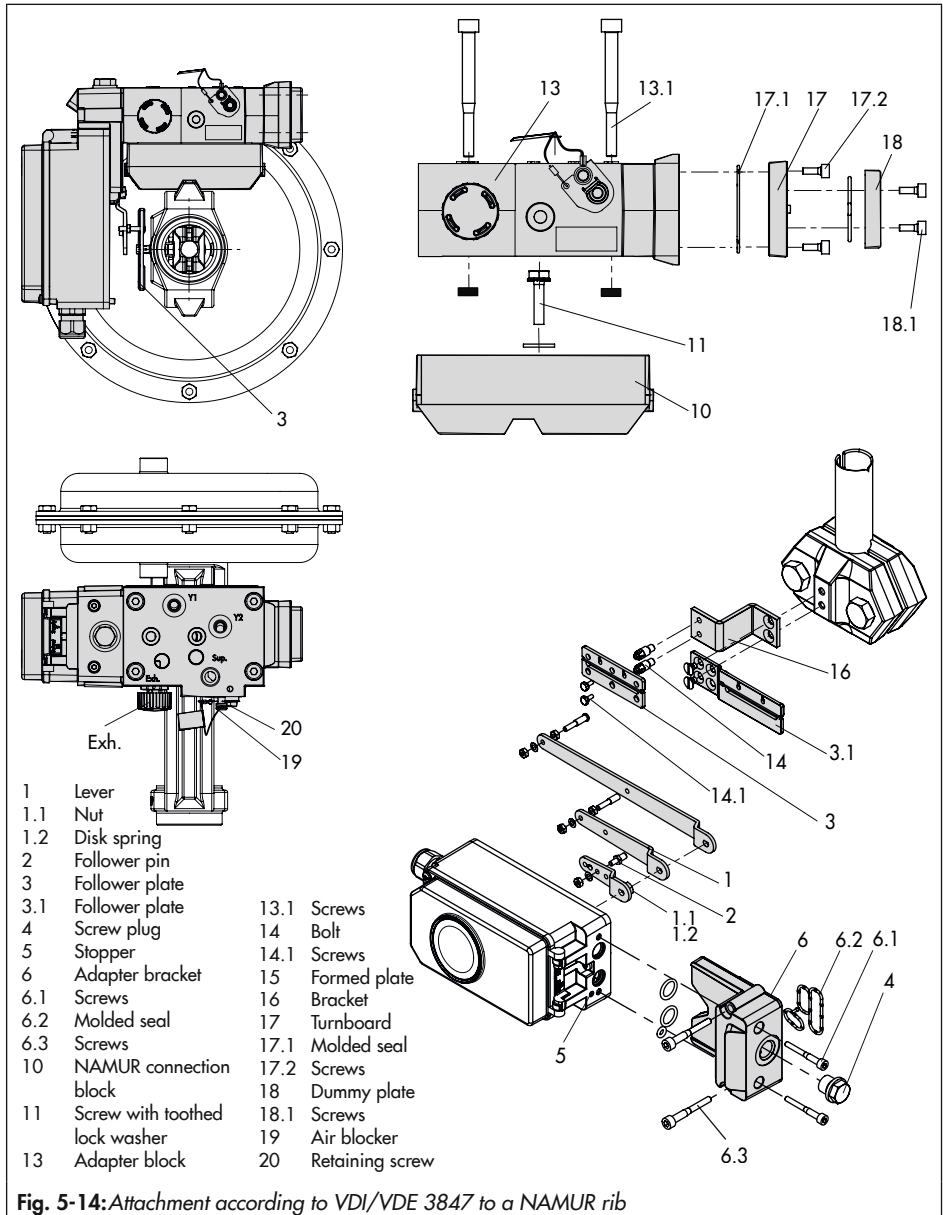

the screw and toothed lock washer (11). Align the marking on the NAMUR valve connection (on the side marked '1') to 50 % travel.

For attachment to **valves with rod-type yokes** using the formed plate (15), which is placed around the yoke: screw the four studs into the NAMUR connection block (10). Place the NAMUR connection block on the rod and position the formed plate (15) on the opposite side. Use the nuts and toothed lock washers to fasten the formed plate onto the studs. Align the marking on the NAMUR valve connection (on the side marked '1') to 50 % travel.

3. Place the adapter bracket (6) on the positioner and mount using the screws (6.1). Make sure that the seals are correctly seated. For positioners **with air purging**, remove the stopper (5) before mounting the positioner. For positioners **without air purging**, replace the screw plug (4) with a vent plug.
4. Select required lever size (1) M, L or XL and pin position according to the actuator size and valve travel listed in the travel table on page 5-4.

Should a pin position other than position 35 with the standard M lever be required or an L or XL lever size be required, proceed as follows:

- Fasten the follower pin (2) in the assigned lever hole (pin position as specified in the travel table). Only use the longer follower pin (2) included in the mounting kit.

- Place the lever (1) on the shaft of the positioner and fasten it tight using the disk spring (1.2) and nut (1.1).
 - Move lever once all the way as far as it will go in both directions.
5. Insert the molded seal (6.2) in the groove of the adapter bracket.
 6. Insert the molded seal (17.1) into the turnboard (17) and mount the turnboard to the adapter block (13) using the screws (17.2).
 7. Mount the blank plate (18) to the turnboard using the screws (18.1). Make sure that the seals are correctly seated.

i Note

A solenoid valve can also be mounted in place of the blank plate (18). The orientation of the turnboard (17) determines the mounting position of the solenoid valve. Alternatively, a restrictor plate can be mounted (► AB 11).

8. Fasten the adapter block (13) to the NAMUR connection block using the screws (13.1).
 9. Insert the vent plug into the Exh. connection.
 10. Place the positioner on the adapter block (13) in such a manner that the follower pin (2) rests on the top of the follower plate (3, 3.1). Adjust the lever (1) correspondingly.
- Fasten the positioner to the adapter block (13) using the two fastening screws (6.3).

Make sure the molded seal (6.2) is properly seated.

1. For **single-acting actuators without air purging**, connect the Y1 port of the adapter block to the signal pressure connection of the actuator. Seal the Y2 port with a blanking plug.

For **double-acting actuators and actuators with air purging**, connect the Y2 port of the adapter block to the signal pressure connection of the second actuator chamber or spring chamber of the actuator.

5.6.5 Attachment according to VDI/VDE 3847-2

Attachment according to VDI/VDE 3847-2 for SRP (single-acting) and DAP (double-acting) rotary actuators in sizes 60 to 1200 with NAMUR interface and air purging of the actuator's spring chamber allows the direct attachment of the positioner without additional piping.

Additionally, the positioner can be replaced quickly while the process is running by blocking the air in single-acting actuators.

Blocking the actuator in place (see Fig. 5-15):

1. Unscrew the red retaining screw (1).
2. Turn the air blocker (2) on the bottom of the adapter block according to the inscription.

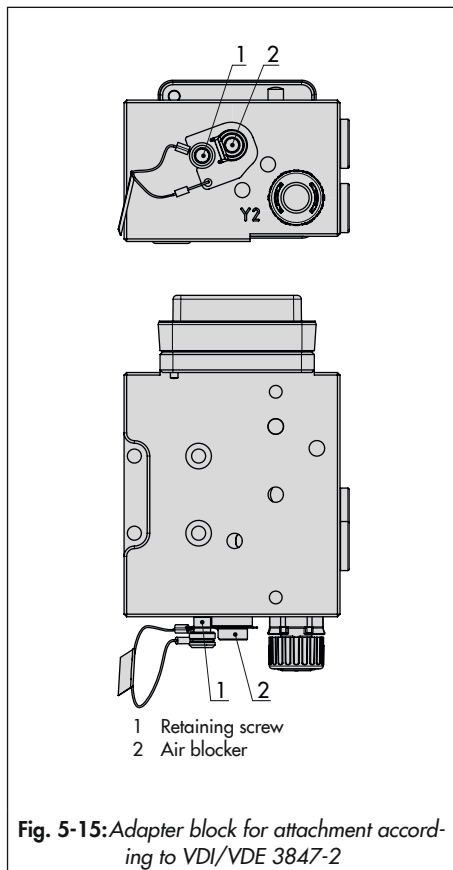

Fig. 5-15: Adapter block for attachment according to VDI/VDE 3847-2

a) Version for single-acting actuator

Mounting on Type 31a Actuator (edition 2020+), SRP version

→ See Fig. 5-17

1. Seal the signal pressure output at the back of the positioner with the screw plug (4, order no. 0180-1254) and the associated O-ring (order no. 0520-0412) if the screw plug is not yet in place.
2. Fasten the adapter block (1) to the actuator's NAMUR interface using the four fastening screws (2).
→ Make sure that the seals are correctly seated.
3. Mount the follower wheel (3) onto the actuator shaft. Use the matching shaft adapter (see Table 5-9 on page 5-52).
4. Place the adapter bracket (4) onto the adapter block (1) and fasten it using the fastening screws (5).
→ Make sure that the seals are correctly seated.
5. Insert and fasten the follower pin in the 90° position on the positioner's lever (see Fig. 5-16). Only use the longer follower pin included in the mounting kit.
6. Align the positioner on the adapter bracket (1) in such a way that the follower pin engages into the actuator's follower wheel (3).

7. Fasten the positioner onto the adapter bracket (4) using the fastening screws (6).
→ Make sure that the seals are correctly seated.

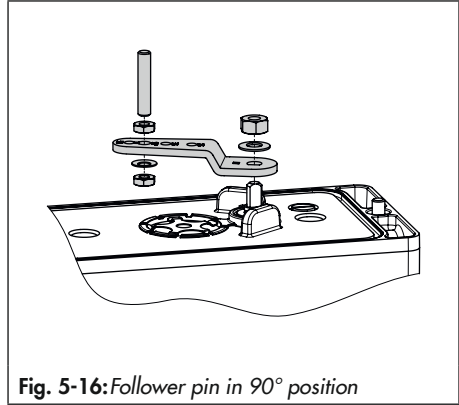
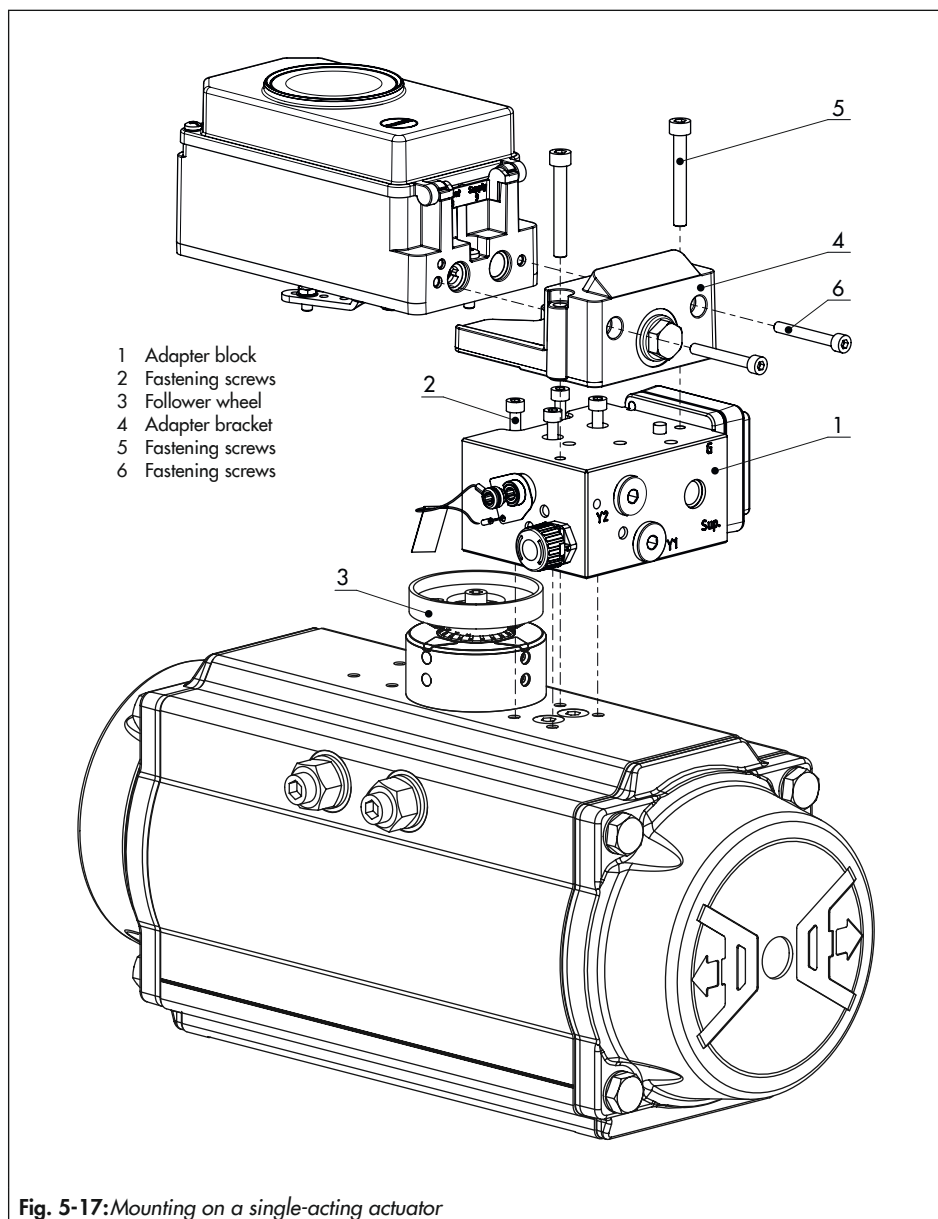

Fig. 5-16: Follower pin in 90° position



b) Version for double-acting actuator

A reversing amplifier must be additionally mounted for applications with double-acting (DAP) actuators or applications with single-acting (SAP) actuators that include partial stroke testing.

In this case, a special adapter bracket (4) is required for mounting.

➔ See Fig. 5-19.

1. Seal the signal pressure output at the back of the positioner with the screw plug (4, order no. 0180-1254) and the associated O-ring (order no. 0520-0412) if the screw plug is not yet in place.
2. Fasten the adapter block (1) to the actuator's NAMUR interface using the four fastening screws (2). Make sure the seals are correctly seated.
3. Mount the follower wheel (3) onto the actuator shaft. Use the matching adapter (see Table 5-9 on page 5-52).
4. Place the adapter bracket (4) onto the adapter block (1) and fasten it using the fastening screws (5). Make sure the seals are correctly seated.
5. Insert and fasten the follower pin into the 90° position on the positioner's lever (see Fig. 5-16 on page 5-20).
6. Align the positioner on the adapter bracket (1) in such a way that the follower pin engages into the actuator's follower wheel (3).
7. Fasten the positioner onto the adapter bracket (4) using the fastening screws (6).
8. Mount the Type 3710 Reversing Amplifier (7) together with the two guide bushings (8) and terminal plate (9) onto the adapter bracket using the associated fastening screws (10). Make sure the seals are correctly seated.
9. Remove the vent plug at the adapter block and seal the opening with the G 1/4 screw plug.
10. Mount the turnboard marked '**Doppel**' for double-acting actuators or the turnboard marked '**PST**' for single-acting actuators with partial stroke testing. See Fig. 5-18. Make sure the seals are correctly seated.

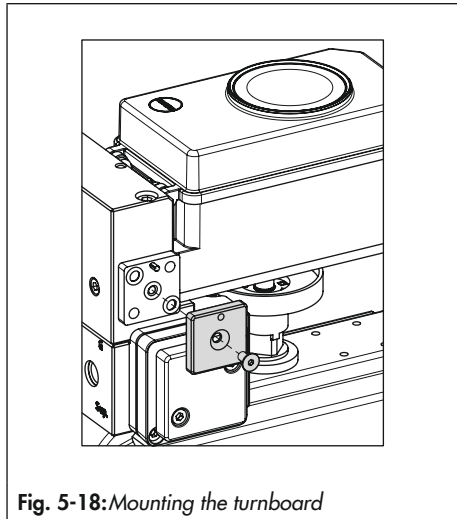
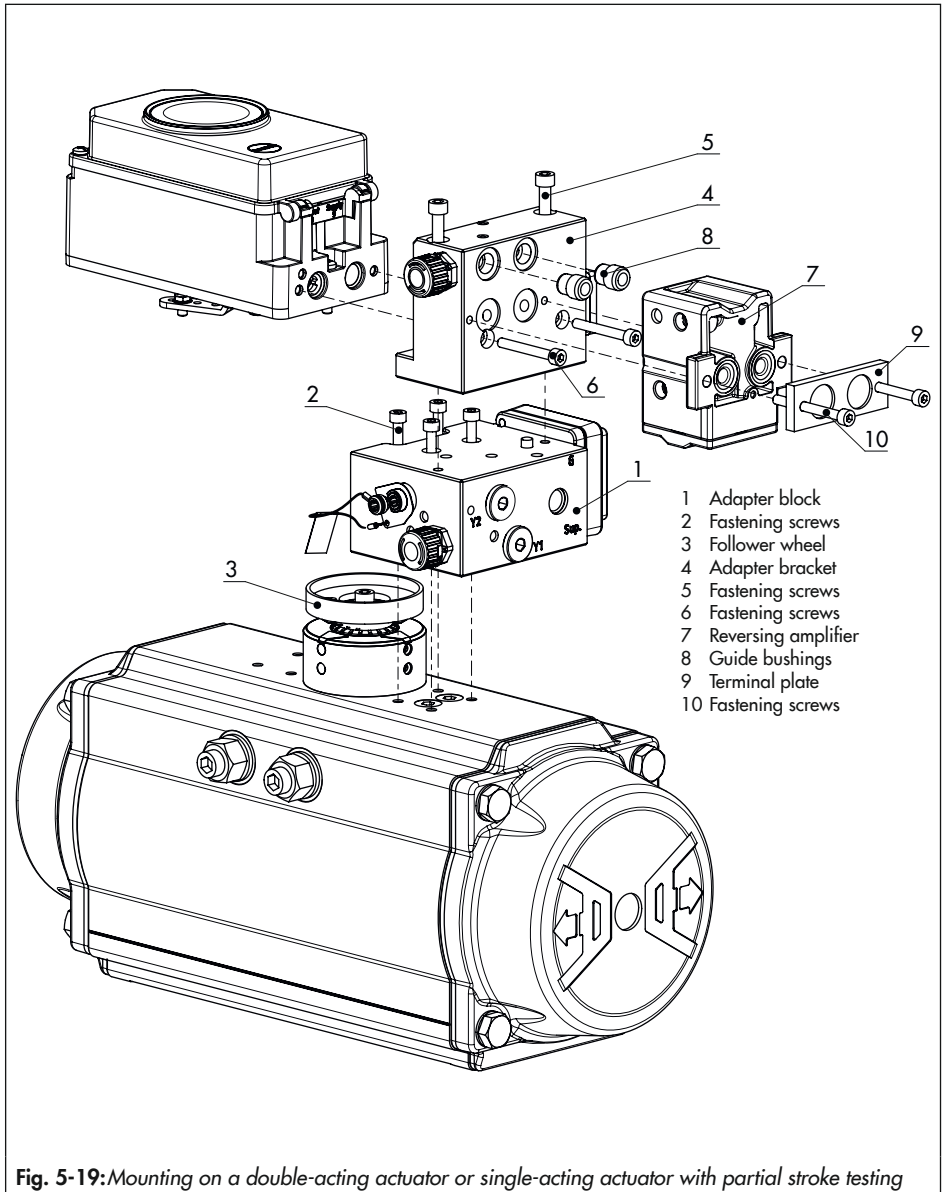

Fig. 5-18: Mounting the turnboard



Installation

Intermediate plate for AA4 interface

→ See Fig. 5-20.

An intermediate plate (1) must be mounted between the adapter block and adapter bracket for SRP and DAP rotary actuators in sizes 900 and 1200 with AA4 interface. This plate is included in the accessories for the shaft adapter AA4 (see Table 5-9 on page 5-52).

Mounting a solenoid valve

→ See Fig. 5-21.

A solenoid valve (12) can also be mounted in place of the blank plate (12). The orientation of the turnboard (14) determines the mounting position of the solenoid valve. Alternatively, a restrictor plate can be mounted. Further information can be found in the document ► AB 11 (Accessories for Solenoid Valves).

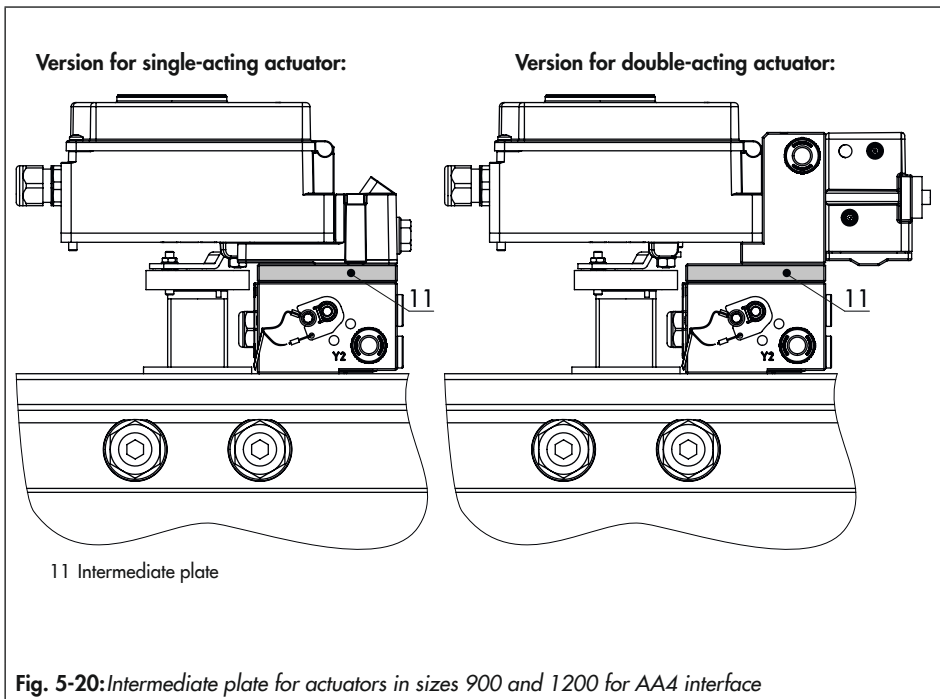

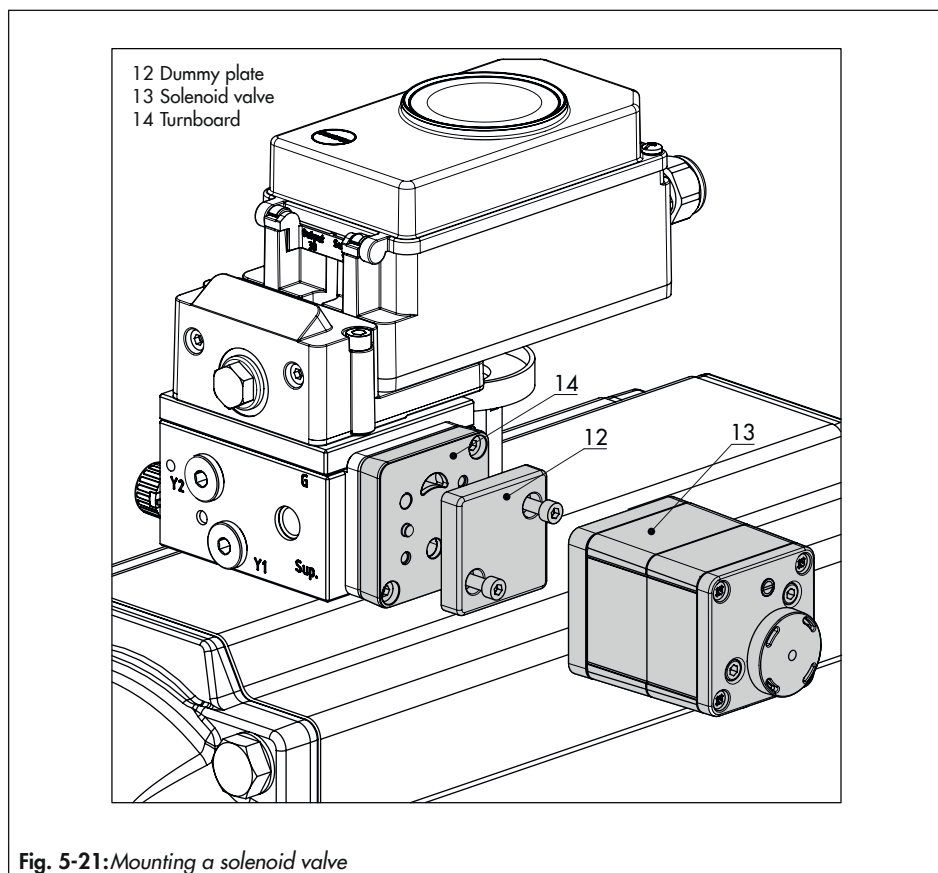

Fig. 5-21: Mounting a solenoid valve

5.6.6 Attachment according to VDI/VDE 3845

- See Fig. 5-23
- Required mounting parts and accessories: Table 5-10 on page 5-52.
- Observe travel tables on page 5-4.

The positioner is mounted to the rotary actuator using two pairs of brackets.

Prior to attaching the positioner to the SAMSON Type 3278 Rotary Actuator, mount the associated adapter (5) to the free end of the rotary actuator shaft.

i Note

On attaching the positioner as described below, it is imperative that the actuator's direction of rotation is observed.

1. Place follower clamp (3) on the slotted actuator shaft or spacer (5).
2. Place coupling wheel (4) with flat side facing the actuator on the follower clamp (3). Align slot so that it matches the direction of rotation when the valve is in its closed position (see Fig. 5-23).
3. Fasten the coupling wheel (4) and follower clamp (3) tightly onto the actuator shaft using screw (4.1) and disk spring (4.2).
4. Fasten the bottom pair of brackets (10.1) with the bends pointing either facing to the inside or to the outside (depending on the actuator size) onto the actuator housing. Position the top pair of brackets (10) and fasten.

5. Mount connecting plate (6) or pressure gauge bracket (7) with pressure gauges on the positioner. Make sure that the two seals (6.1) are seated properly. Double-acting springless rotary actuators require the use of a reversing amplifier on the connection side of the positioner housing (see Chapter 5.6.7).
6. Unscrew the standard follower pin (2) from the positioner's M lever (1). Use the metal follower pin (Ø 5 mm) included in the mounting kit and screw tight into the hole for pin position 90°.
7. Place positioner on the top bracket (10) and fasten tight. Taking the actuator's direction of rotation into account, adjust lever (1) so that it engages in the slot of the coupling wheel (4) with its follower pin (Fig. 5-23). It must be guaranteed that the lever (1) is parallel to the long side of the positioner when the actuator is at half its angle of rotation.

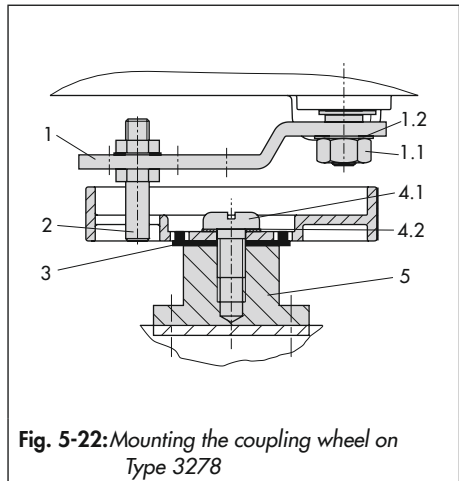
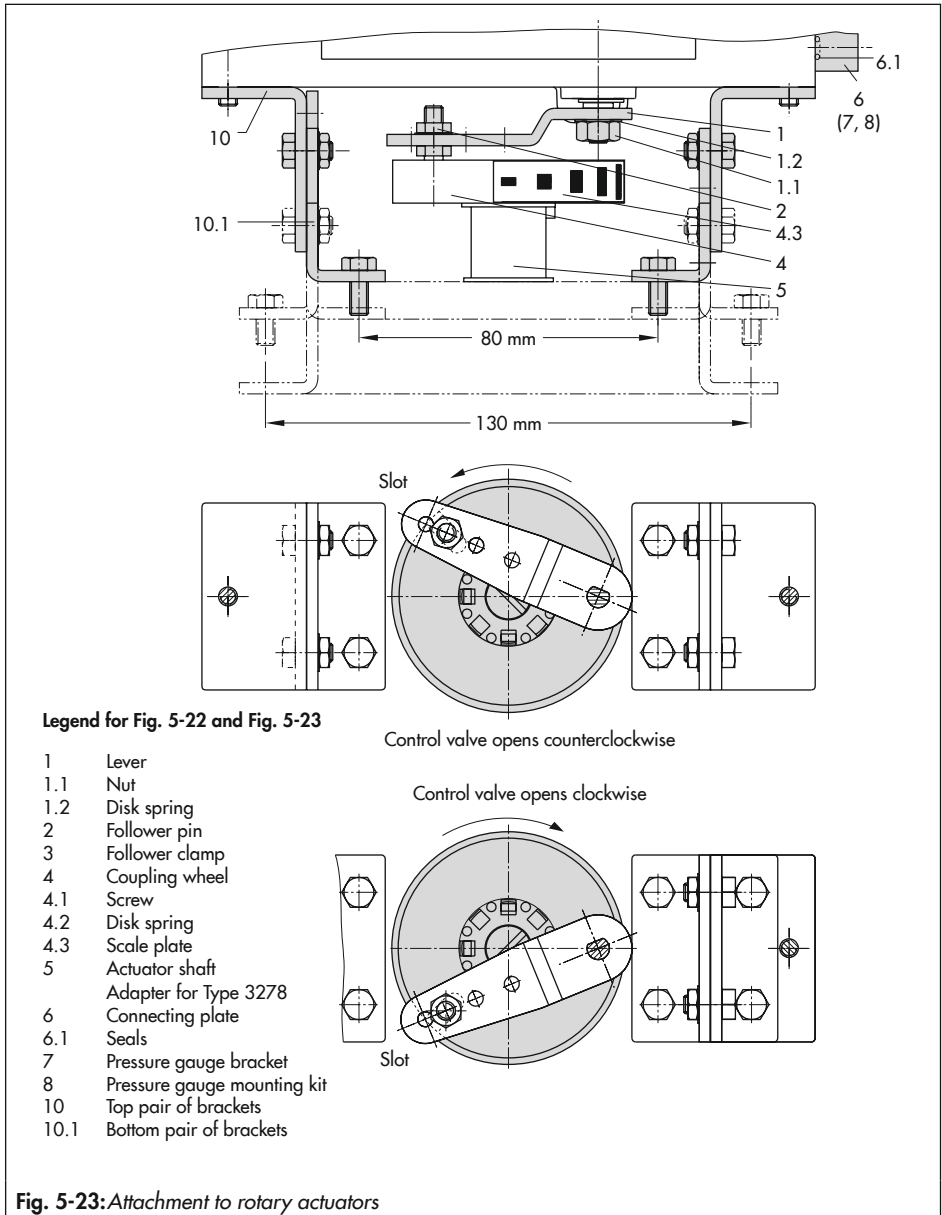

Fig. 5-22: Mounting the coupling wheel on Type 3278



8. Stick the scale plate (4.3) on the coupling wheel so that the arrow tip indicates the closed position and it can be easily read when the valve is installed.

a) Heavy-duty version

i Note

We recommend using a volume restriction (see Chapter 5.5) for actuators with a volume of less than 300 cm³.

- See Fig. 5-25
- Required mounting parts and accessories: Table 5-10 on page 5-52.

Both mounting kits contain all the necessary mounting parts. The parts for the actuator size used must be selected from the mounting kit.

Prepare actuator and mount possibly required adapter supplied by the actuator manufacturer.

1. Seal the signal pressure output at the back of the positioner with the screw plug (4, order no. 0180-1254) and the associated O-ring (order no. 0520-0412) if the screw plug is not yet in place.
2. Mount the housing (10) onto the rotary actuator. In case of VDI/VDE attachment, place spacers (11) underneath, if necessary.

3. For **SAMSON Type 3278 and VETEC S160 Rotary Actuators**, fasten the adapter (5) onto the free end of the shaft and for **VETEC R Actuator**, place on the adapter (5.1). For **Type 3278, VETEC S160 and VETEC R Actuators**, place on the adapter (3). For **Type 3278, VETEC S160 and VETEC R Actuators**, place on the adapter (3). For VDI/VDE version, this step depends on the actuator size.
4. Stick adhesive label (4.3) onto the coupling in such a manner that the yellow part of the sticker is visible in the window of the housing when the valve is OPEN. Adhesive labels with explanatory symbols are enclosed and can be stuck on the housing, if required.
5. Fasten coupling wheel (4) on the slotted actuator shaft or adapter (3) using screw (4.1) and disk spring (4.2).

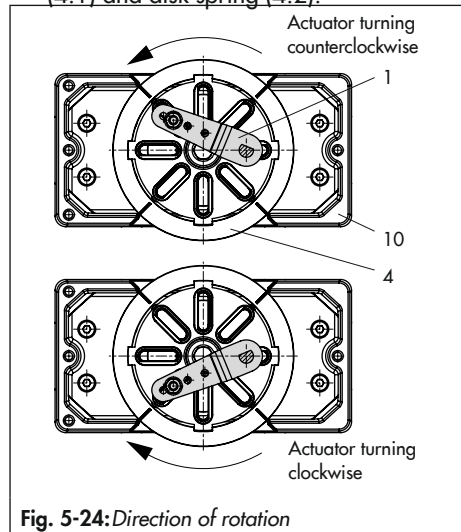

Fig. 5-24: Direction of rotation

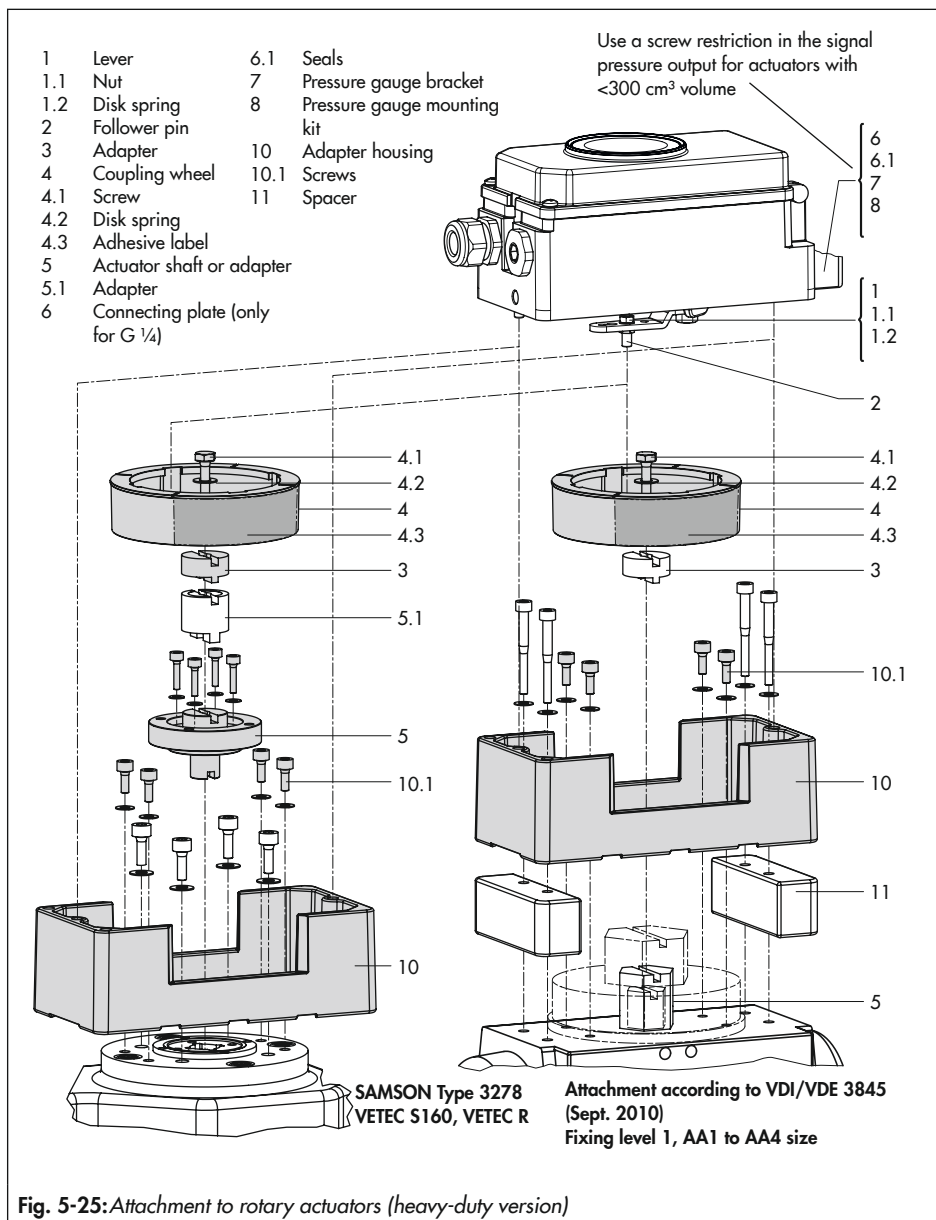

Fig. 5-25: Attachment to rotary actuators (heavy-duty version)

Installation

6. Unscrew the standard follower pin (2) from the positioner's M lever (1). Attach the follower pin (Ø5 mm) included in the mounting kit to pin position 90°.
7. Mount connecting plate (6) for required G ¼ connecting thread or pressure gauge bracket (7) with pressure gauges on the positioner. Make sure that the two seals (6.1) are seated properly. Double-acting springless rotary actuators require the use of a reversing amplifier on the connection side of the positioner housing (see Chapter 5.6.7).
8. Place positioner on housing (10) and screw it tight. Taking the actuator's direction of rotation into account, adjust lever (1) so that it engages in the correct slot with its follower pin (Fig. 5-24).

5.6.7 Reversing amplifier for double-acting actuators

For the use with double-acting actuators, the positioner must be fitted with a reversing amplifier:

- SAMSON Type 3710 Reversing Amplifier,
▶ EB 8392

The following applies to all reversing amplifiers:

The signal pressure of the positioner is supplied at the output 1 of the reversing amplifier. An opposing pressure, which equals the required supply pressure (Z) when added to the pressure at output 1, is applied at output 2.

The following relationship applies:

output 1 + output 2 = Supply pressure (Z).

Connect output 1 to the signal pressure connection on the actuator that causes the valve to open when the pressure rises.

Connect output 2 to the signal pressure connection on the actuator that causes the valve to close when the pressure rises.

5.6.8 Attachment of external position sensor

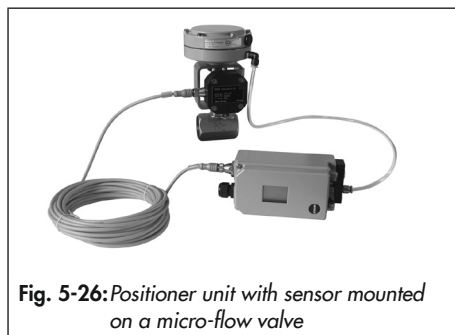

Fig. 5-26: Positioner unit with sensor mounted on a micro-flow valve

- Required mounting parts and accessories: see Table 5-11

In the positioner version with an external position sensor, the sensor located in a separate housing is attached over a plate or bracket to the control valve. The travel pick-off corresponds to that of a standard device.

The positioner can be mounted as required to a wall or a pipe.

For the pneumatic connection either a connecting plate (6) or a pressure gauge bracket (7) must be fixed to the housing, depending on the accessory chosen. Make sure the seals (6.1) are correctly inserted (see Fig. 5-10, bottom right).

For the electrical connection a 10 meter connecting lead with M12x1 connectors is included in the scope of delivery.

i Note

- In addition, the instructions in Chapters 5.7 and 5.8 apply for the pneumatic and electrical connection.
 - Since 2009, the back of the position sensor (20) is fitted with two pins acting as mechanical stops for the lever (1). If this position sensor is mounted using old mounting parts, two corresponding $\varnothing 8$ mm holes must be drilled into the mounting plate/bracket (21). A template is available for this purpose. See Table 5-11.
-

a) Mounting the position sensor with direct attachment

Type 3277-5 Actuator with 120 cm² (Fig. 5-27)

The signal pressure from the positioner is routed over the signal pressure connection of the connecting plate (9, Fig. 5-27 left) to the actuator diaphragm chamber. To proceed, first screw the connecting plate (9) included in the accessories onto the actuator yoke.

- Turn the connecting plate (9) so that the correct symbol for the fail-safe action "actuator stem extends" or "actuator stem retracts" is aligned with the marking (Fig. 5-27, below).
- Make absolutely sure that the gasket for the connecting plate (9) is correctly inserted.
- The connecting plate has threaded holes with NPT and G threads. Seal the threaded connection that is not used with the rubber seal and square plug.

Type 3277 Actuator with 175 to 750 cm²:

The signal pressure is routed to the connection at the side of the actuator yoke for the version with fail-safe action "actuator stem extends". For the fail-safe action "actuator stem retracts" the connection on the top diaphragm case is used. The connection at the side of the yoke must be fitted with a venting plug (accessories).

Mounting the position sensor

1. Place the lever (1) on the sensor in mid-position and hold it in place. Unthread the nut (1.1) and remove the lever together with the disk spring (1.2) from the sensor shaft.
2. Screw the position sensor (20) onto the mounting plate (21).
3. Depending on the actuator size and rated valve travel, determine which lever and position of the follower pin (2) is to be used from the travel table in Chapter 5.4.1. The positioner is delivered with

Installation

- the **M** lever in pin position **35** on the sensor. If necessary, remove the follower pin (2) from its pin position and move it to the hole for the recommended pin position and screw tight.
- Place the lever (1) and disk spring (1.2) on the sensor shaft. Place the lever in **mid-position** and **hold it in place**. Screw on the nut (1.1).
 - Place follower clamp (3) on the actuator stem, align it and screw tight so that the mounting screw is located in the groove of the actuator stem.
 - Place the mounting plate together with the sensor onto the actuator yoke so that the follower pin (2) rests on the top of the follower clamp (3). It must rest on it with spring force. Fasten the mounting plate (21) onto the actuator yoke using both fixing screws.
 - Mount cover (11) on the other side. Make sure that the vent plug is located at the bottom when the control valve is installed to allow any condensed water that collects to drain off.

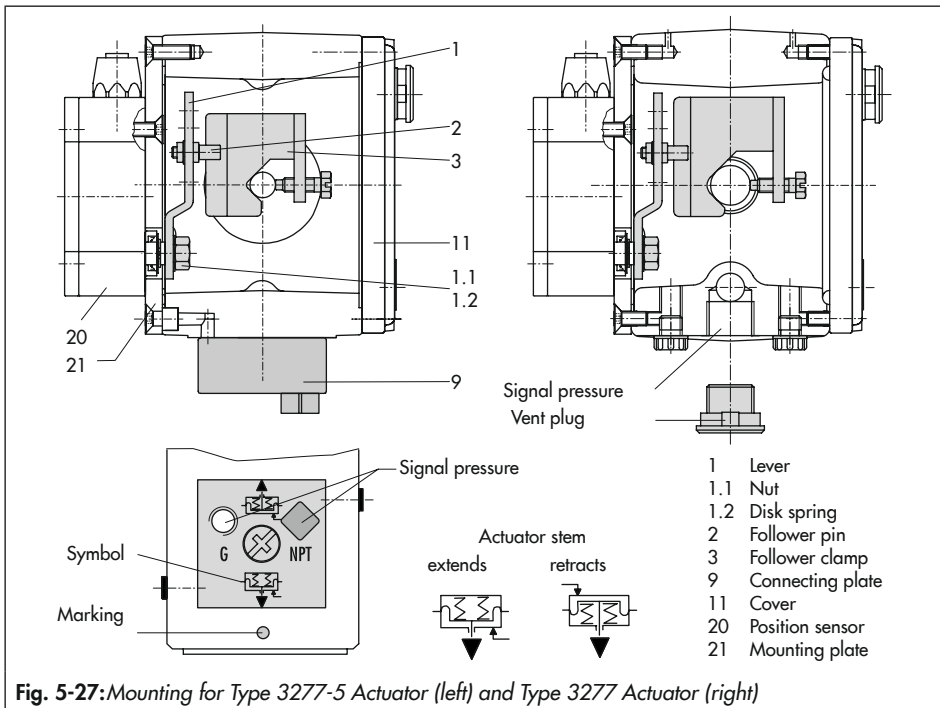

Fig. 5-27: Mounting for Type 3277-5 Actuator (left) and Type 3277 Actuator (right)

b) Mounting the position sensor with attachment according to IEC 60534-6

- Required mounting parts and accessories: see Table 5-11
 - See Fig. 5-28.
1. Place the lever (1) on the position sensor in **mid-position** and **hold it in place**. Unthread the nut (1.1) and remove the lever together with the disk spring (1.2) from the sensor shaft.
 2. Screw the position sensor (20) onto the bracket (21).

The standard attached **M** lever with the follower pin (2) at position **35** is designed for 120 to 350 cm² actuators with 15 mm rated

travel. For other actuator sizes or travels, select the lever and pin position from the travel table in Chapter 5.4.1. L and XL levers are included in the mounting kit.

3. Place the lever (1) and disk spring (1.2) on the sensor shaft. Place the lever in **mid-position** and **hold it in place**. Screw on the nut (1.1).
4. Screw the two bolts (14) to the bracket (9.1) of the stem connector (9), place the follower plate (3) on top and use the screws (14.1) for fastening.
5. Place the bracket with the sensor at the NAMUR rib in such a manner that the follower pin (2) rests in the slot of the follower plate (3), then screw the bracket using its fixing screws onto the valve.

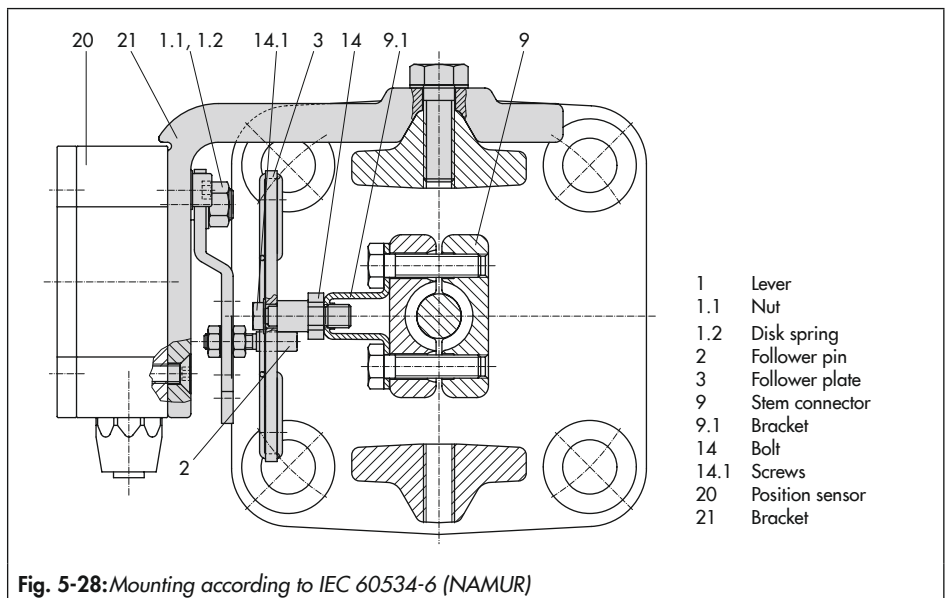

c) Mounting the position sensor to Type 3510 Micro-flow Valve

➔ Required mounting parts and accessories: see Table 5-11

➔ See Fig. 5-29.

1. Place the lever (1) on the position sensor in **mid-position** and **hold it in place**. Unscrew the nut (1.1) and remove the standard attached **M** lever (1) together with the disk spring (1.2) from the sensor shaft.

2. Screw the position sensor (20) onto the bracket (21).
3. Select the **S** lever (1) from the accessories and screw the follower pin (2) into the hole for pin position **17**. Place the lever (1) and disk spring (1.2) on the sensor shaft. Place the lever in mid-position and hold it in place. Screw on the nut (1.1).
4. Place follower clamp (3) on the valve stem connector, align at a right angle and screw tight.
5. Position the bracket (21) with the position sensor on the valve yoke and screw tight, making sure the follower pin (2) slides into the groove of the follower clamp (3).

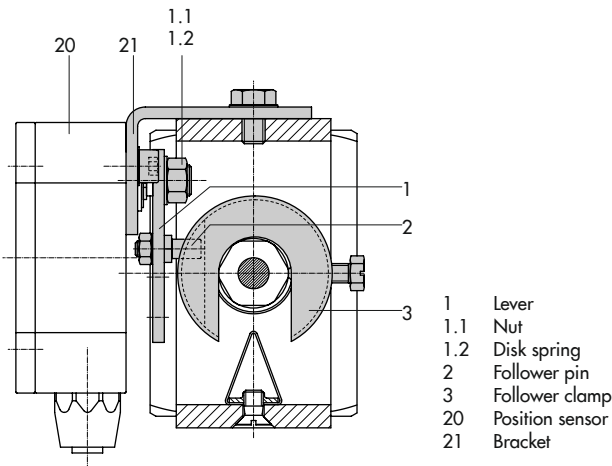

Fig. 5-29: Mounting on a micro-flow valve

d) Mounting on rotary actuators

- Required mounting parts and accessories: see Table 5-11
 - See Fig. 5-30.
1. Place the lever (1) on the position sensor in **mid-position** and **hold it in place**. Unthread the nut (1.1) and remove the lever together with the disk spring (1.2) from the sensor shaft.
 2. Screw the position sensor (20) onto the mounting plate (21).
 3. Replace the follower pin (2) normally attached to the lever (1) with the metal fol-

lower pin ($\varnothing 5$ mm) from the accessories and screw it into the hole for pin position 90° .

4. Place the lever (1) and disk spring (1.2) on the sensor shaft. Place the lever **in mid-position** and **hold it in place**. Screw on the nut (1.1).

Follow the instructions describing attachment to the standard positioner in Chapter 5.6.3.

Instead of the positioner, attach the position sensor (20) with its mounting plate (21).

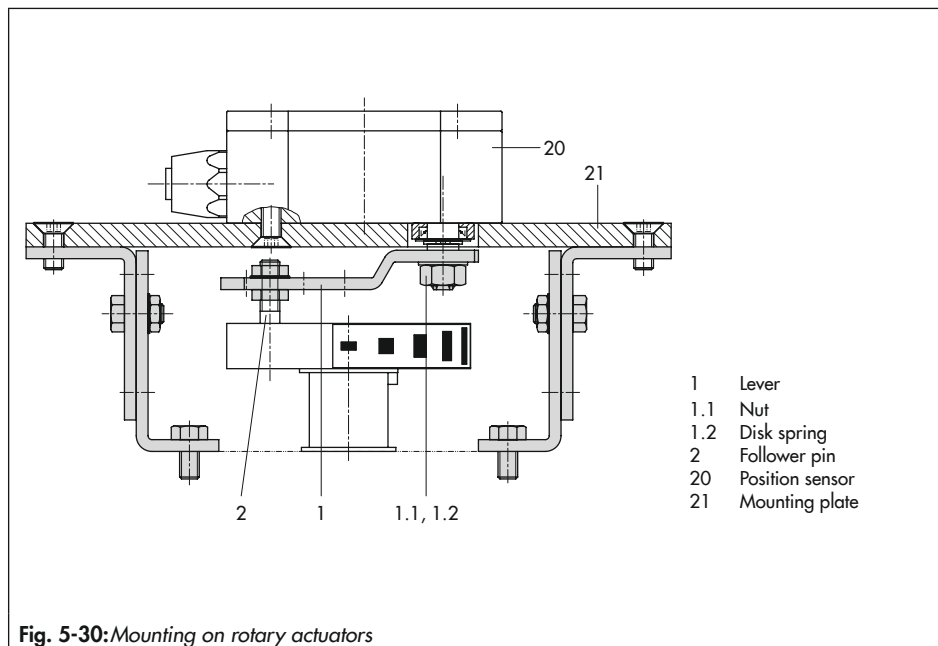

Fig. 5-30: Mounting on rotary actuators

5.6.9 Attaching positioners with stainless steel housings

Positioners with stainless steel housings require mounting parts that are completely made of stainless steel or free of aluminum.

i Note

The pneumatic connecting plate and pressure gauge bracket are available in stainless steel (order numbers listed below). The Type 3710 Pneumatic Reversing Amplifier is also available in stainless steel.

Connecting plate (stainless steel)	G ¼ ¼ NPT	1400-7476 1400-7477
Pressure gauge bracket (stainless steel)	G ¼ ¼ NPT	1402-0265 1400-7108

Table 5-4 to Table 5-10 apply for attaching positioners with stainless steel housings with the following restrictions:

Direct attachment

All mounting kits from Table 5-5 and Table 5-6 can be used. The connection block is not required. The stainless steel version of the pneumatic connecting plate routes the air internally to the actuator.

Attachment according to IEC 60534-6 (NAMUR rib or attachment to rod-type yokes)

All mounting kits from Table 5-7 can be used. Connecting plate in stainless steel.

Attachment to rotary actuators

All mounting kits from Table 5-10 can be used except for the heavy-duty version. Connecting plate in stainless steel.

5.6.10 Air purging function for single-acting actuators

The instrument air leaving the positioner is diverted to the actuator spring chamber to provide corrosion protection inside the actuator. Observe the following:

Direct attachment to Type 3277-5 (stem extends FA/stem retracts FE)

The air purging function is automatically provided.

Direct attachment to Type 3277, 175 to 750 cm²

Stem extends: remove the stopper (12.2, Fig. 5-9) at the black connection block and make a pneumatic connection to the spring chamber on the vented side.

Stem retracts: the air purging function is automatically provided.

Attachment according to IEC 60534-6 (NAMUR rib or attachment to rod-type yokes) and to rotary actuators

The positioner requires an additional port for the exhaust air that can be connected over piping. An adapter available as an accessory is used for this purpose:

Threaded bushing (M20x1.5)	G ¼ ¼ NPT	0310-2619 0310-2550
----------------------------	--------------	------------------------

i Note

The adapter uses one of the M20x1.5 connections in the housing which means **only one** cable gland can be installed.

Should other valve accessories be used which vent the actuator (e.g. solenoid valve, volume booster, quick exhaust valve), this exhaust air must also be included in the purging function. The connection over the adapter at the positioner must be protected with a check valve (e.g. screw fitting with restriction G 1/4, order no. 1991-5777) or 1/4 NPT (order no. 1992-3178) mounted in the piping. Otherwise the pressure in the positioner housing would rise above the ambient pressure and damage the positioner when the exhausting components respond suddenly.

5.7 Establishing pneumatic connections

⚠ WARNING

Risk of injury by possible movement of exposed parts (positioner, actuator or valve) after connecting the signal pressure.

→ Do not touch or block exposed moving parts.

ⓘ NOTICE

Incorrect connection of the supply air will damage the positioner and will lead to malfunction.

→ Screw the screw fittings into the connecting plate, pressure gauge mounting block or connection block from the accessories.

The pneumatic ports are located on the back of the positioner (see Fig. 5-31).

ⓘ NOTICE

Risk of malfunction due to failure to comply with air quality requirements.

- Only use supply air that is dry and free of oil and dust.
- Read the maintenance instructions for upstream pressure reducing stations.
- Blow through all air pipes and hoses thoroughly before connecting them.

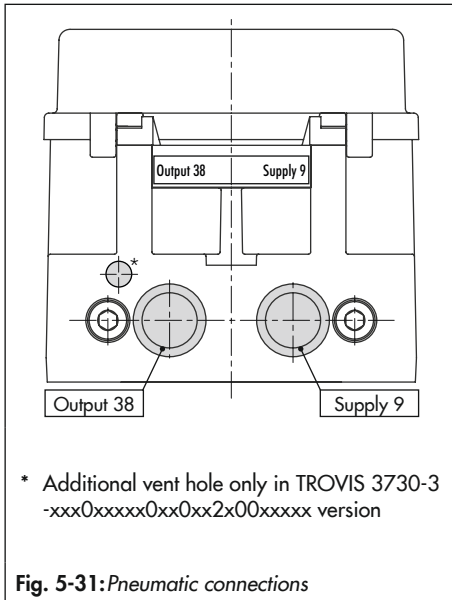

5.7.1 Supply air

⚠ WARNING

Sudden loud noise when the pneumatic actuator vents.

→ Wear hearing protection when working near the valve.

ⓘ NOTICE

Risk of malfunction due to incorrect sequence of mounting, installation and start-up.

- Observe the following sequence.
1. Remove the protective caps from the pneumatic connections.
 2. Mount the positioner on the valve.
 3. Connect the supply air.
 4. Connect the electrical power.
 5. Perform settings.

The pneumatic connections in the connecting plate, pressure gauge mounting block and connection block are optionally designed as a bore with $\frac{1}{4}$ NPT or G $\frac{1}{4}$ thread. Customary fittings for metal or copper tubing or plastic hoses can be used.

→ Read instructions in Chapter 5.7.

5.7.2 Signal pressure connection

The signal pressure connection depends on how the positioner is mounted onto the actuator:

Type 3277 Actuator

→ The signal pressure connection is fixed.

Attachment according to IEC 60534-6 (NAMUR)

- For "actuator stem retracts" fail-safe action: connect the signal pressure to the connection on top of the actuator.
- For "actuator stem extends" fail-safe action: connect the signal pressure to the connection on bottom of the actuator.

Rotary actuators (heavy-duty version)

→ For rotary actuators, the manufacturer's specifications for connection apply.

5.7.3 Signal pressure reading



Tip

To monitor the supply air and signal pressure, we recommend mounting pressure gauges (see accessories in Chapter 5.9).

Mounting the pressure gauges:

→ See Chapter 5.6.2 and Fig. 5-10.

5.7.4 Supply pressure

The required supply air pressure depends on the bench range and the actuator's direction of action (fail-safe action).

The bench range is written on the nameplate either as the bench range or signal pressure range depending on the actuator. The direction of action is marked FA or FE or by a symbol.

Actuator stem extends FA (AIR TO OPEN)

Fail-close (for globe and angle valves):

→ Required supply pressure = Upper bench range value + 0.2 bar, at least 1.4 bar.

Actuator stem retracts FE (AIR TO CLOSE)

Fail-open (for globe and angle valves):

For tight-closing valves, the maximum signal pressure p_{st_max} is roughly estimated as follows:

$$p_{st_max} = F + \frac{d^2 \cdot \pi \cdot \Delta p}{4 \cdot A} \quad [\text{bar}]$$

d = Seat diameter [cm]

Δp = Differential pressure across the valve [bar]

A = Actuator area [cm²]

F = Upper bench range value of the actuator [bar]

If there are no specifications, calculate as follows:

→ Required supply pressure = Upper bench range value + 1 bar

5.8 Establishing electrical connections

⚠ DANGER

Risk of fatal injury due to the formation of an explosive atmosphere.

→ For installation in hazardous areas, observe the relevant standards that apply in the country of use.

Standard applicable in Germany:
EN 60079-14 (VDE 0165, Part 1) Explosive Atmospheres – Electrical Installations Design, Selection and Erection.

⚠ WARNING

Incorrect electrical connection will render the explosion protection unsafe.

- Adhere to the terminal assignment.
- Do not undo the enameled screws.

⚠ WARNING

Intrinsic safety rendered ineffective in intrinsically safe devices.

- Only connect intrinsically safe devices intended for use in intrinsically safe circuits to certified intrinsically safe input-connected units.
- Do not place intrinsically safe devices back into operation that were connected to intrinsically safe input-connected units without certification.
- Do not exceed the maximum permissible electric values specified in the EC type examination certificates when interconnecting intrinsically safe electrical equip-

ment (U_i or U_o , I_i or I_o , P_i or P_o , C_i or C_o and L_i or L_o).

⚠ WARNING

Sudden loud noise when the pneumatic actuator vents.

- Wear hearing protection when working near the valve.

Selecting cables and wires

- Observe the relevant clauses of EN 60079-14 for installation of intrinsically safe circuits.
- Seal cable entries left unused with plugs.
- Fit equipment used in ambient temperatures below -20 °C with metal cable entries.

Equipment with type of protection Ex nA

In equipment operated according to type of protection Ex nA (non-sparking equipment), circuits may be connected, interrupted or switched while energized only during installation, maintenance or repair.

Use certified cable glands and blanking plugs with appropriate type of protection and IP rating $\geq 6X$ and suitable for the certified temperature range.

The signal circuit is connected using screw terminals (terminal 11/12) for electrical conductors with a wire cross-section from 0.2 to 2.5 mm². The tightening torque is 0.5 to 0.6 Nm.

Equipment with type of protection Ex t

In equipment operated according to type of protection Ex t (protection by enclosure), circuits may be connected, interrupted or switched while energized only during installation, maintenance or repair.

Opening the enclosure cover in potentially explosive dust atmospheres during operation may cause the explosion protection to become ineffective.

Use certified cable glands and blanking plugs with appropriate type of protection and IP rating $\geq 6X$ and suitable for the certified temperature range.

The signal circuit is connected using screw terminals (terminal 11/12) for electrical conductors with a wire cross-section from 0.2 to 2.5 mm². The tightening torque is 0.5 to 0.6 Nm.

In general, it is not necessary to connect the positioner to a bonding conductor. Should this be required, however, this conductor can be connected inside or outside of the device.

5.8.1 Cable entry with cable gland

The housing of the TROVIS 3730-3 Positioner has two threaded boreholes, which can be fitted with cable glands as required.

- The cable gland version depends on the ambient temperature range (see technical data in the 'Design and principle of operation' chapter).
- The screw terminals are designed for wire cross-sections of 0.2 to 2.5 mm² (tightening torque 0.5 Nm).
- Connect **one** current source at the maximum.

5.8.2 Electrical power

NOTICE

Risk of malfunction due to incorrect sequence of mounting, installation and start-up.

- Observe the following sequence.
1. Remove the protective caps from the pneumatic connections.
 2. Mount the positioner on the valve.
 3. Connect the supply air.
 4. Connect the electrical power.
 5. Perform settings.
-
- Connect options as shown in Fig. 5-32 to Fig. 5-37, if necessary.
- Connect the electrical power (mA signal) as shown in Fig. 5-38.

Accessories

Cable glands M20x1.5	Order no.
Black plastic (6 to 12 mm clamping range)	8808-1011
Blue plastic (6 to 12 mm clamping range)	8808-1012
Nickel-plated brass (6 to 12 mm clamping range)	1890-4875
Nickel-plated brass (10 to 14 mm clamping range)	1992-8395
Stainless steel 1.4305 (8 to 14.5 mm clamping range)	8808-0160
Adapter M20x1.5 to ½ NPT	
Powder-coated aluminum	0310-2149
Stainless steel	1400-7114

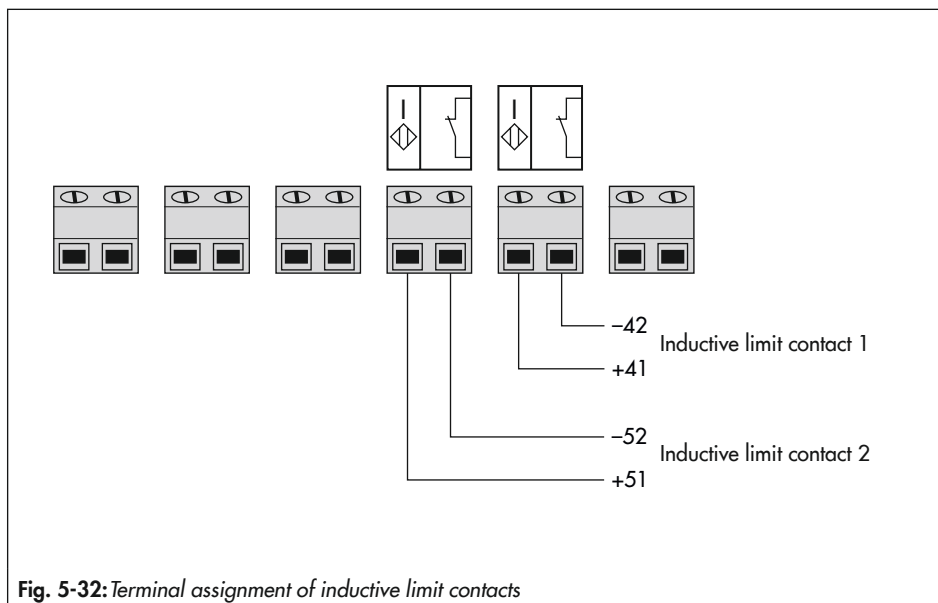

Fig. 5-32: Terminal assignment of inductive limit contacts

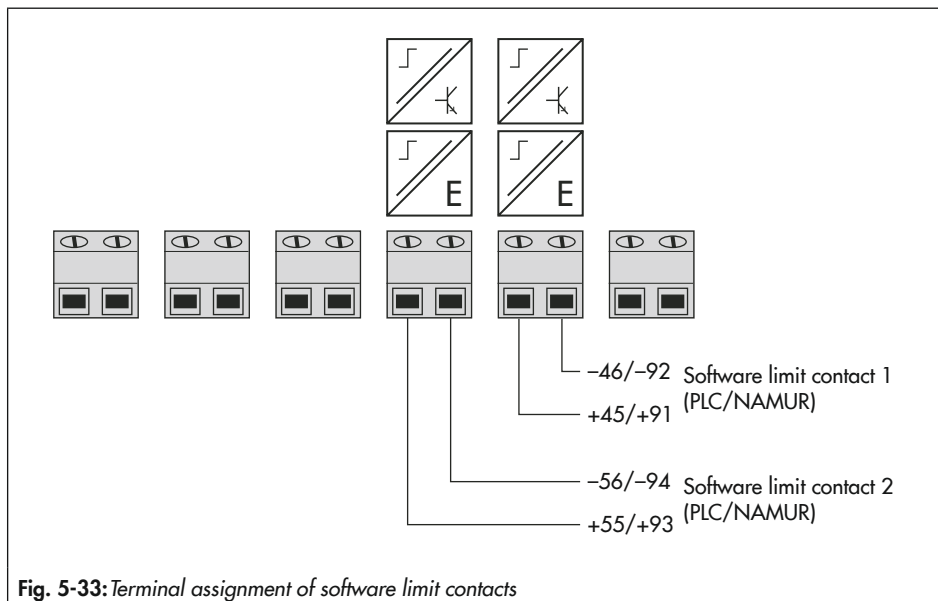

Fig. 5-33: Terminal assignment of software limit contacts

Installation

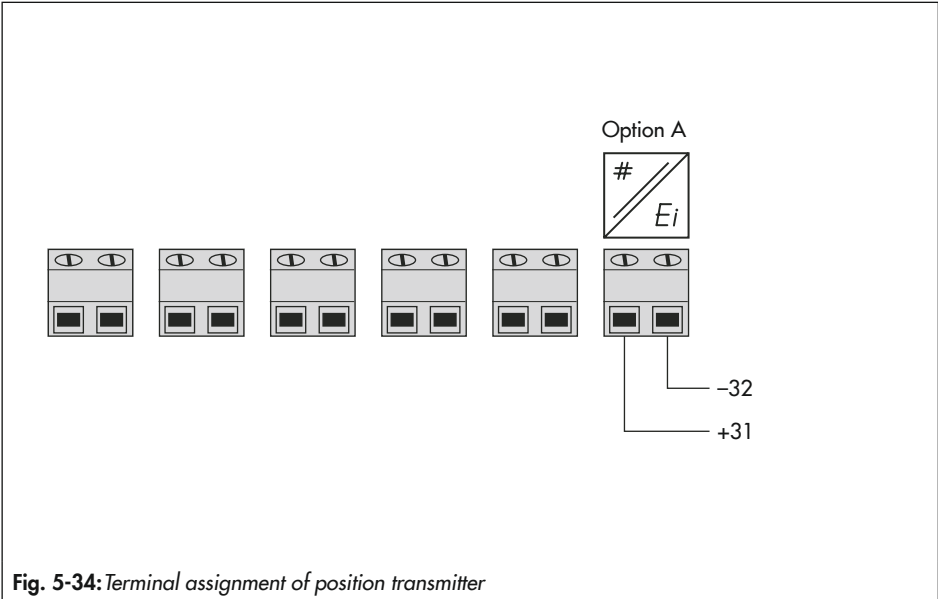

Fig. 5-34: Terminal assignment of position transmitter

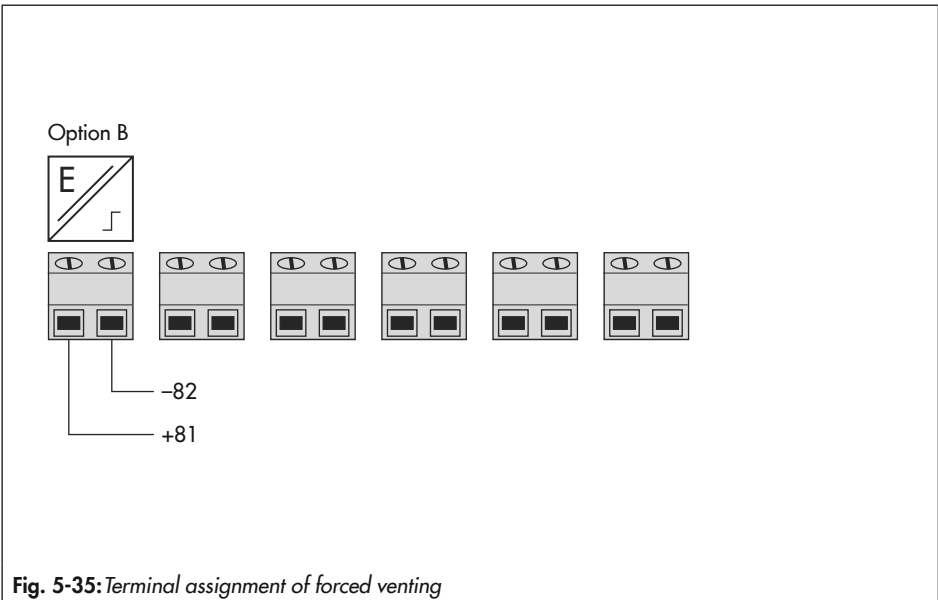

Fig. 5-35: Terminal assignment of forced venting

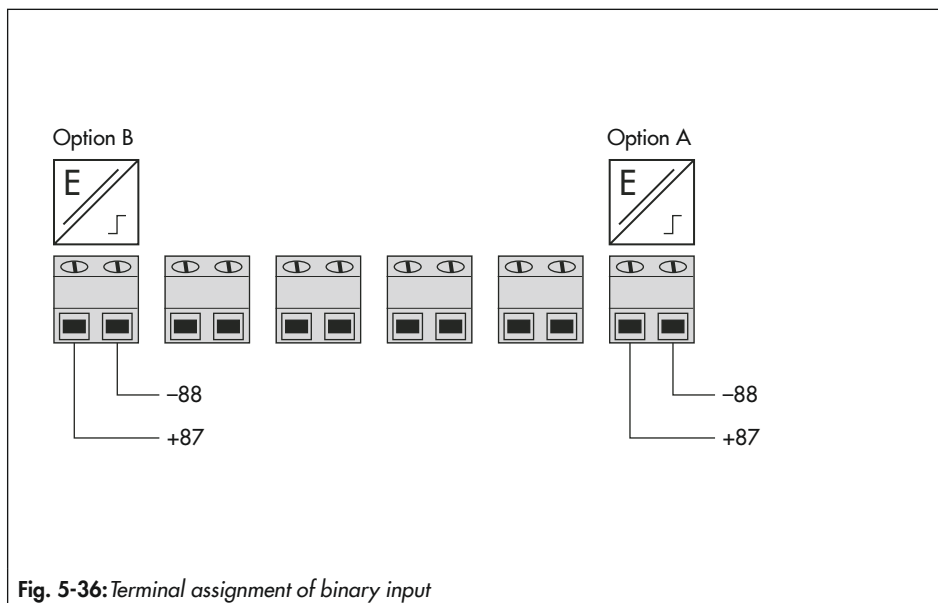

Fig. 5-36: Terminal assignment of binary input

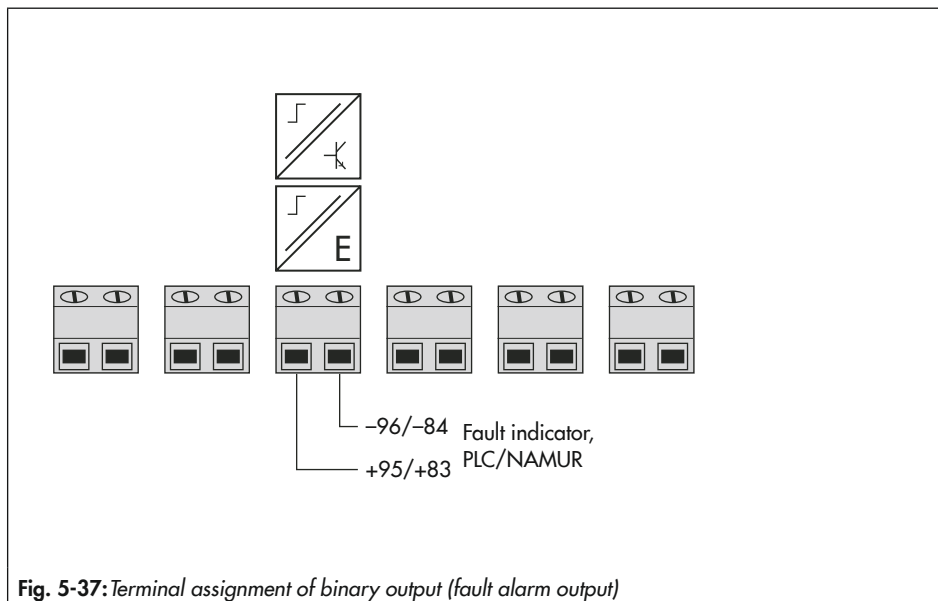

Fig. 5-37: Terminal assignment of binary output (fault alarm output)

Installation

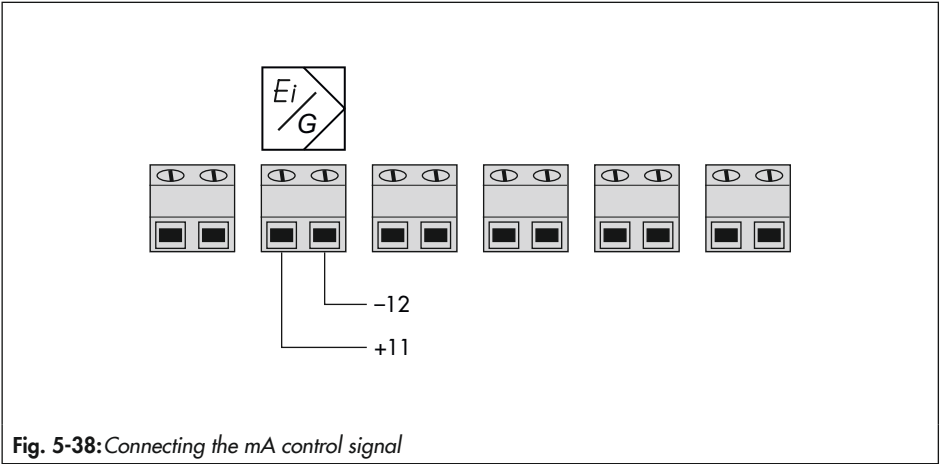

Fig. 5-38: Connecting the mA control signal

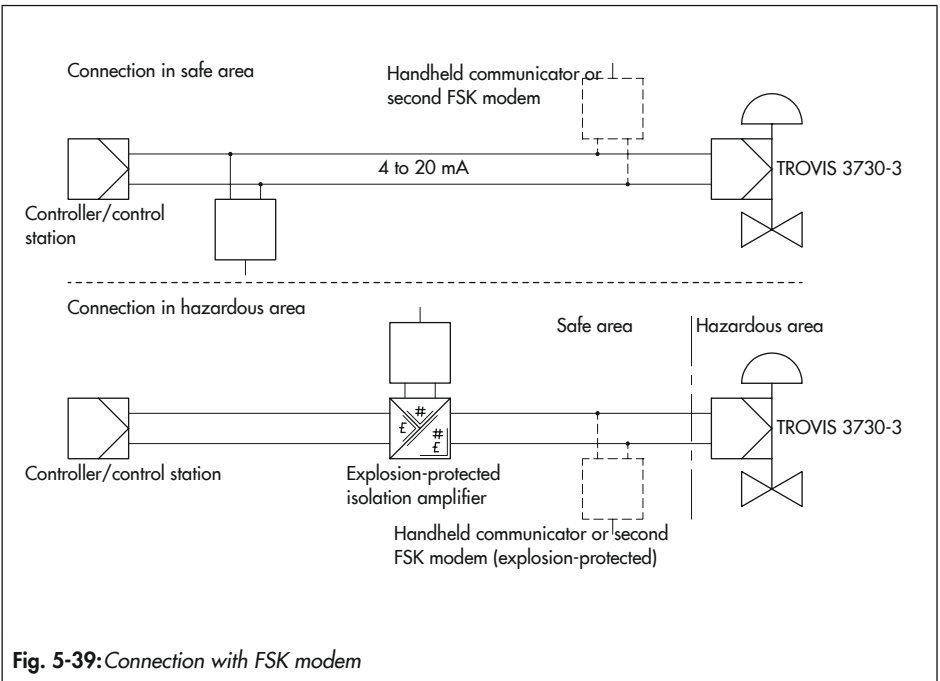

Fig. 5-39: Connection with FSK modem

5.8.3 Establishing HART® communication

Communication between computer and positioner using an FSK modem or handheld communicator (if necessary, using an isolation amplifier) is based on the HART® protocol.

Viator FSK modem

- RS-232 Not ex Order no. 8812-0130
- USB Not ex Order no. 8812-0132

If the load impedance of the controller or control station is too low, an isolation amplifier must be connected between controller and positioner (interfacing as for positioner connected in hazardous areas). See Fig. 5-39.

If the positioner is used in hazardous areas, an explosion-protected isolation amplifier must be used.

Using the HART® protocol, all connected control room and field units can be addressed individually with their address using a standard bus.

Standard bus:

In the standard bus mode, the positioner follows the analog set point. The bus address/polling address has to be within a range of 1 to 15.

When communication errors occur:

Communication errors may occur when the process controller/control station output is not HART®-compatible.

Alternatively, a $250\ \Omega$ resistor can be connected in series and a $22\ \mu\text{F}$ capacitor can be connected in parallel to the analog output of positioners without explosion protection and positioners with type of protection Ex tb (Fig. 5-40). The load for the controller output will increase as a result.

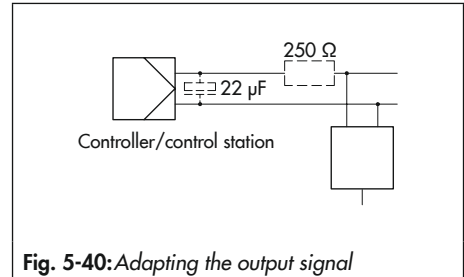

Fig. 5-40: Adapting the output signal

5.8.4 Switching amplifier according to EN 60947-5-6

For operation of the limit contacts, switching amplifiers must be connected in the output circuit. They must comply with the limit values of the output circuits conforming to EN 60947-5-6.

➔ Observe the relevant regulations for installation in hazardous areas.

For applications in safe areas (non-hazardous areas), software limit contacts can be directly interconnected to the binary input of the PLC in accordance with IEC 61131. This applies to the standard operating range for digital inputs according to Clause 5.2.1.2 of IEC 61131-2 with the rated voltage of 24 V DC.

5.9 Accessories

Table 5-4: *General accessories*

Designation	Order no.	
Reversing amplifier for double-acting actuators	Type 3710	
Cable gland M20x1.5	Black plastic (6 to 12 mm clamping range)	8808-1011
	Blue plastic (6 to 12 mm clamping range)	8808-1012
	Nickel-plated brass (6 to 12 mm clamping range)	1890-4875
	Nickel-plated brass (10 to 14 mm clamping range)	1992-8395
	Stainless steel 1.4305 (8 to 14.5 mm clamping range)	8808-0160
Adapter M20x1.5 to ½ NPT	Powder-coated aluminum	0310-2149
	Stainless steel	1400-7114
M lever	0510-0510	
L lever	0510-0511	
XL lever	0510-0512	
XXL lever	0510-0525	
Volume restriction	For mounting on the connection block	100041955
	For mounting on the connecting plate/pressure gauge bracket	100041162
Isolated USB interface adapter (SSP interface to USB port on a computer)	1400-9740	
TROVIS-VIEW 6661 (www.samsongroup.com > SERVICE & SUPPORT > Downloads > TROVIS-VIEW)		

Table 5-5: Direct attachment to Type 3277-5 (see Chapter 5.6.1 a))

Designation		Order no.	
Mounting parts	Standard version for actuators 120 cm ² or smaller	1400-7452	
	Version compatible with paint for actuators 120 cm ² or smaller	1402-0940	
Accessories for actuator	Old switchover plate for Type 3277-5xxxxxx. 00 Actuator (old)	1400-6819	
	New switchover plate for Type 3277-5xxxxxx. 01 Actuator (new) ¹⁾	1400-6822	
	New connecting plate for Type 3277-5xxxxxx. 01 Actuator (new) ¹⁾ , G 1/8 and 1/8 NPT	1400-6823	
	Old connecting plate for Type 3277-5xxxxxx. 00 Actuator (old); G 1/8	1400-6820	
	Old connecting plate for Type 3277-5xxxxxx. 00 (old); 1/8 NPT	1400-6821	
Accessories for positioner	Connecting plate (6)	G 1/4	1400-7461
		1/4 NPT	1400-7462
	Pressure gauge bracket (7)	G 1/4	1400-7458
		1/4 NPT	1400-7459
	Pressure gauge mounting kit (8) up to max. 6 bar	Stainless steel/brass	1402-1637
		Stainless steel/stainless steel	1402-1638

¹⁾ Only new switchover and connecting plates can be used with new actuators (Index 01). Old and new plates are not interchangeable.

Installation

Table 5-6: Direct attachment to Type 3277 (see Chapter 5.6.1 b))

Mounting parts/accessories		Order no.
Standard version for actuators 175, 240, 350, 355, 700, 750 cm ²		1400-7453
Version compatible with paint for actuators 175, 240, 350, 355, 700, 750 cm ²		1402-0941
Connection block with seals and screw	G ¼	1400-8819
	¼ NPT	1402-0901
Pressure gauge mounting kit up to max. 6 bar	Stainless steel/brass	1402-1637
	Stainless steel/stainless steel	1402-1638
Volume restriction for connection block (recommended for <240 cm ²)		100041955
Piping with screw fittings ¹⁾		Order no.
Actuator (175 cm ²), steel	G ¼/G ¾	1402-0970
	¼ NPT/¾ NPT	1402-0976
Actuator (175 cm ²), stainless steel	G ¼/G ¾	1402-0971
	¼ NPT/¾ NPT	1402-0978
Actuator (240 cm ²), steel	G ¼/G ¾	1400-6444
	¼ NPT/¾ NPT	1402-0911
Actuator (240 cm ²), stainless steel	G ¼/G ¾	1400-6445
	¼ NPT/¾ NPT	1402-0912
Actuator (350 cm ²), steel	G ¼/G ¾	1400-6446
	¼ NPT/¾ NPT	1402-0913
Actuator (350 cm ²), stainless steel	G ¼/G ¾	1400-6447
	¼ NPT/¾ NPT	1402-0914
Actuator (355 cm ²), steel	G ¼/G ¾	1402-0972
	¼ NPT/¾ NPT	1402-0979
Actuator (355 cm ²), stainless steel	G ¼/G ¾	1402-0973
	¼ NPT/¾ NPT	1402-0980
Actuator (700 cm ²), steel	G ¼/G ¾	1400-6448
	¼ NPT/¾ NPT	1402-0915
Actuator (700 cm ²), stainless steel	G ¼/G ¾	1400-6449
	¼ NPT/¾ NPT	1402-0916
Actuator (750 cm ²), steel	G ¼/G ¾	1402-0974
	¼ NPT/¾ NPT	1402-0981
Actuator (750 cm ²), stainless steel	G ¼/G ¾	1402-0975
	¼ NPT/¾ NPT	1402-0982

¹⁾ For "actuator stem retracts" direction of action;
with air purging of the top diaphragm chamber;
air purging of the diaphragm chamber for "actuator stem extends" direction of action

Table 5-7: Attachment to NAMUR rib or attachment to rod-type yokes ¹⁾ according to IEC 60534-6 (Chapter 5.6.2)

Travel (mm)	Lever	For actuator	Order no.
7.5	S	Type 3271-5 with 60/120 cm ² on Type 3510 Micro-flow Valve	1402-0478
5 to 50	M ²⁾	Actuators from other manufacturers and Type 3271 with 120 to 750 cm ² areas	1400-7454
14 to 100	L	Actuators from other manufacturers and Type 3271 with 1000 and 1400-60 cm ²	1400-7455
30 or 60	L	Type 3271, 1400-120 and 2800 cm ² versions with 30/60 mm travel ³⁾	1400-7466
		Mounting brackets for Emerson and Masoneilan linear actuators (in addition, a mounting kit according to IEC 60534-6 is required depending on the travel). See rows above.	1400-6771
		Valtek Type 25/50	1400-9554
40 to 200	XL	Actuators from other manufacturers and Type 3271 with 1400-120 and 2800 cm ² and with 120 mm travel	1400-7456
Accessories			Order no.
Connecting plate	G ¼		1400-7461
	¼ NPT		1400-7462
Pressure gauge bracket	G ¼		1400-7458
	¼ NPT		1400-7459
Pressure gauge mounting kit up to max. 6 bar	Stainless steel/brass		1402-1637
	Stainless steel/stainless steel		1402-1638

¹⁾ 20 to 35 mm rod diameter

²⁾ M lever is mounted on basic device (included in the scope of delivery)

³⁾ In conjunction with Type 3273 Side-mounted Handwheel with 120 mm rated travel, additionally one bracket (0300-1162) and two countersunk screws (8330-0919) are required.

Table 5-8: Attachment according to VDI/VDE 3847-1 (see Chapter 5.6.4)

Mounting parts			Order no.
VDI/VDE 3847 interface adapter			1402-0257
Connecting plate, including connection for air purging of actuator spring chamber	Aluminum	ISO 228/1-G ¼	1402-0268
		¼-18 NPT	1402-0269
	Stainless steel	ISO 228/1-G ¼	1402-0270
		¼-18 NPT	1402-0271
Mounting kit for attachment to SAMSON Type 3277 Actuator with 175 to 750 cm ²			1402-0868
Mounting kit for attachment to SAMSON Type 3271 Actuator or third-party actuators			1402-0869
Travel pick-off for valve travel up to 100 mm			1402-0177
Travel pick-off for 100 to 200 mm valve travel (SAMSON Type 3271 Actuator only)			1402-0178

Table 5-9: Attachment according to VDI/VDE 3847-2 (see Chapter 5.6.5)

Designation		Order no.
Mounting parts	Mounting block for PFEIFFER Type 31a (edition 2020+) Rotary Actuators with blank plate for solenoid valve interface	1402-1645
	Blank plate for solenoid valve interface (sold individually)	1402-1290
	Adapter bracket for Series 3730 (VDI/VDE 3847)	1402-0257
	Adapter bracket for Series 3730 and Type 3710 (DAP/PST)	1402-1590
Accessories for actuator	Shaft adapter AA1	1402-1617
	Shaft adapter AA2	1402-1616
	Shaft adapter AA4	1402-1888

Table 5-10: Attachment to rotary actuators (see Chapter 5.6.6)

Mounting parts/accessories		Order no.	
Attachment according to VDI/VDE 3845 (September 2010), actuator surface corresponds to fixing level 1			
Size AA1 to AA4, version with CrNiMo steel bracket		1400-7448	
Size AA1 to AA4, heavy-duty version		1400-9244	
Size AA5, heavy-duty version (e.g. Air Torque 10 000)		1400-9542	
Bracket surface corresponds to fixing level 2, heavy-duty version		1400-9526	
Attachment for rotary actuators with max. 180° opening angle, fixing level 2		1400-8815 and 1400-9837	
Attachment to SAMSON Type 3278 with 160/320 cm ² , CrNiMo steel bracket		1400-7614	
Attachment to SAMSON Type 3278 with 160 cm ² and to VETEC Type S160, Type R and Type M, heavy-duty version		1400-9245	
Attachment to SAMSON Type 3278 with 320 cm ² and to VETEC Type S320, heavy-duty version		1400-5891 and 1400-9526	
Attachment to Camflex II		1400-9120	
Accessories	Connecting plate	G ¼	1400-7461
		¼ NPT	1400-7462
	Pressure gauge bracket	G ¼	1400-7458
		¼ NPT	1400-7459
	Pressure gauge mounting kit up to max. 6 bar	Stainless steel/brass	1402-1637
		Stainless steel/stainless steel	1402-1638
	Volume restriction for connection block (recommended for actuators with <300 cm ³ volume)		100041162

Table 5-11: Attachment of external position sensor (see Chapter 5.6.8)

Mounting parts/accessories		Order no.	
Template for mounting position sensor on older mounting parts		1060-0784	
Direct attachment	Mounting parts for actuator with 120 cm ²	1400-7472	
	Connecting plate (9, old) with Type 3277-5xxxxxx.00 Actuator	G 1/8	1400-6820
		1/8 NPT	1400-6821
	Connecting plate (new) with Type 3277-5xxxxxx.01 Actuator (new) ¹⁾	1400-6823	
Mounting parts for actuators with 175, 240, 350, 355 and 750 cm ²		1400-7471	
NAMUR attachment	Mounting parts for attachment to NAMUR rib using L or XL lever	1400-7468	
Attachment to Type 3510 Micro-flow Valve	Mounting parts for Type 3271 Actuator with 60 cm ²	1400-7469	
Attachment to rotary actuators	VDI/VDE 3845 (September 2010)		
	Actuator surface corresponds to fixing level 1		
	Size AA1 to AA4 with follower clamp and coupling wheel, version with CrNiMo steel bracket	1400-7473	
	Size AA1 to AA4, heavy-duty version	1400-9384	
	Size AA5, heavy-duty version (e.g. Air Torque 10 000)	1400-9992	
	Bracket surface corresponds to fixing level 2, heavy-duty version		1400-9974
SAMSON Type 3278 with 160 cm ² and VETEC Type S160 and Type R, heavy-duty version		1400-9385	
SAMSON Type 3278 with 320 cm ² and VETEC Type S320, heavy-duty version		1400-5891 and 1400-9974	
Accessories for positioner	Connecting plate (6)	G 1/4	1400-7461
		1/4 NPT	1400-7462
	Pressure gauge bracket (7)	G 1/4	1400-7458
		1/4 NPT	1400-7459
	Pressure gauge mounting kit up to max. 6 bar (output/supply)	Stainless steel/brass	1402-0938
		Stainless steel/stainless steel	1402-0939
Bracket to mount the positioner on a wall (Note: The other fastening parts are to be provided at the site of installation as wall foundations vary from site to site).		0309-0184	

¹⁾ Only new connecting plates can be used with new actuators (Index 01). Old and new plates are not interchangeable.

6 Operation

⚠ WARNING

Sudden loud noise when the pneumatic actuator vents.

→ Wear hearing protection when working near the valve.

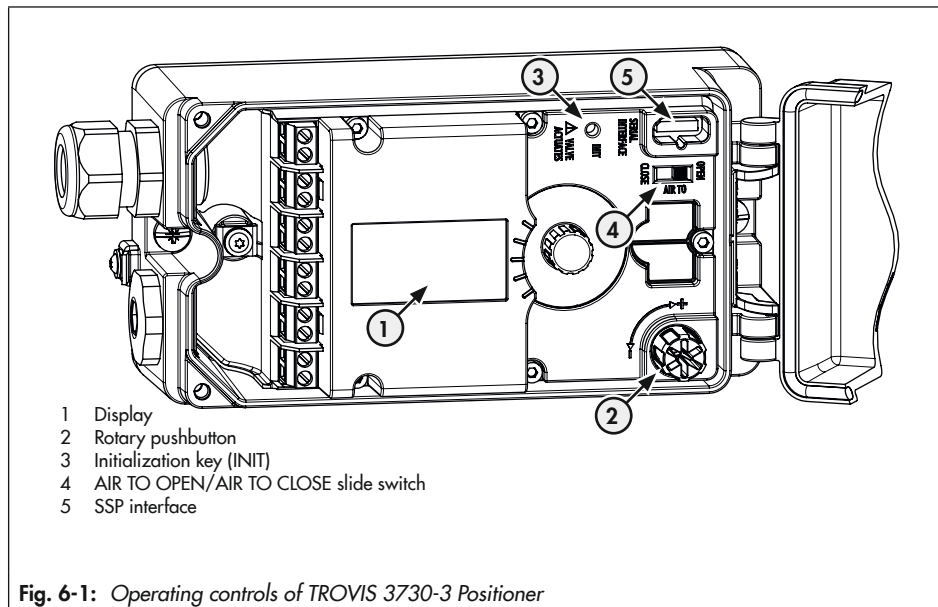

6.1 Rotary pushbutton

The rotary pushbutton for on-site operation is located next to the display (bottom right or top left, depending on the mounting position).

- ⊗ Turn: select menu item, parameters or values.
- ⊗ Press: confirm setting.
- ⊗ Keep pressed down for two seconds: return to menu level (**ESC** with progress bar appears).

6.2 AIR TO OPEN/AIR TO CLOSE slide switch

→ See the 'Start-up and configuration' chapter.

6.3 Initialization key (INIT)

⚠ WARNING

Risk of injury by exposed moving parts on the positioner, actuator or valve.

→ *Do not touch or block exposed moving parts.*

ⓘ NOTICE

The process is disturbed by the movement of the actuator or valve.

→ *Do not perform the initialization while the process is running. First isolate the plant by closing the shut-off valves.*

For normal operation, simply start initialization by pressing the INIT key after mounting the positioner on the valve. In this case, the initialization is performed using the MAX initialization mode (see the 'Start-up and configuration' chapter). Additionally, the default settings in the parameter list (see Appendix A) apply.

Proceed as follows for fast initialization:

1. Mount the positioner on the valve.
2. Connect the supply air.
3. Connect the electrical power.
→ During the first start-up, the wizard is displayed (see the 'Start-up and configuration' chapter).
4. Set the ATO/ATC slider switch to match the valve's fail-safe position as described in Chapter 6.2.
5. Use a thin object to press the initialization key (INIT).

6.4 Display

i Note

The display's operating range is from -20 to $+65$ °C. The readability of the display is restricted outside this temperature range.

As soon as the electrical power (mA control signal) is connected, the **wizard** is displayed during the first start-up (see the 'Start-up and configuration' chapter) and, in all other cases, the **main display** (Fig. 6-2, left) appears, which is marked by the display numbering **0-0** to **0-10** (at the top right-hand corner of the display). Displayed icons provide information on the operating mode, status etc. (see Chapter 6.4.1). Press the **⊗** key to go from the main display to the **menu level** (Fig. 6-2, right). All settings can be made and functions executed in the menu level. The 'Start-up and configuration' chapter contains a description of the basic start-up settings. A list of the menu structure and parameters for on-site operation is included in Appendix A.

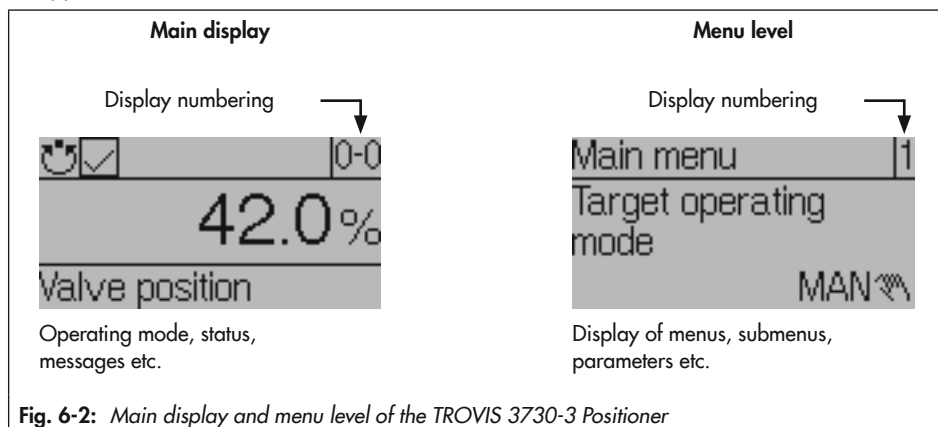

Fig. 6-2: Main display and menu level of the TROVIS 3730-3 Positioner

- ➔ Turn **⊗** clockwise to scroll through from display 0-0 to 0-4. Displays 0-0 to 0-4 are hidden or shown depending on the positioner's operating mode, configuration, status etc.
- ➔ Press **⊗** to go from the **main display** to the **menu level**.

Operation

Table 6-1: Summary of readings in the main display

View	Description
0-0	Start screen: Valve position in %
0-1	Valve position in degrees
0-2	Set point in %
0-3	Set point deviation in %
0-4	Messages

i Note





Some of the messages (display 0-9) can be confirmed: in this case, select the message and press  (only possible when the configuration is enabled, see the 'Start-up and configuration' chapter).

Readings in the menu level

→ See Appendix A for the menu structure and parameters for on-site operation.

6.4.1 Display icons

Table 6-2: Operating modes

Icon	Operating mode	Description
	Automatic mode	The positioner is in closed-loop operation and follows the mA signal.
	Manual mode	The positioner follows the manual set point instead of the mA signal.
	SAFE (fail-safe position)	The positioner vents the pneumatic actuator at its pneumatic output.
	Open-loop control mode ¹⁾	The open-loop control mode allows the valve position to be adjusted manually (even when the positioner has not been initialized).
	Function mode	The positioner initialization or a test is in progress.

¹⁾ The open-loop control mode cannot be directly selected and is the same as the manual mode when the positioner has not yet been initialized.

Table 6-3: *NAMUR status*











Icon	Meaning
	Failure
	Function check
	Out of specification
	Maintenance demanded
	OK (no message)

Table 6-4: *Other icons*

Icon	Meaning
	Write protection, configuration not enabled
	Option installed in Slot C
	Option installed in Slot D
	Binary contact 1 active
	Binary contact 2 active
	Binary contact 3 active

7 Start-up and configuration

The work described in this chapter is only to be performed by personnel appropriately qualified to carry out such tasks.

DANGER

Risk of fatal injury due to the ignition of an explosive atmosphere.

- Observe EN 60079-14 (VDE 0165, Part 1) for work on the positioner in potentially explosive atmospheres.
 - Work in potentially explosive atmospheres must only be performed by personnel who has undergone special training or instructions or who is authorized to work on explosion-protected devices in hazardous areas.
-

WARNING

Crush hazard arising from moving parts on the valve.

- Do not touch any moving valve parts while the control valve is in operation.
 - Before performing any mounting or installation work on the positioner, put the control valve out of operation by disconnecting and locking the supply air and control signal.
 - Do not impede the movement of the actuator and plug stem by inserting objects into the yoke.
-

WARNING

Sudden loud noise when the pneumatic actuator vents.

- Wear hearing protection when working near the valve.
-

Before start-up, make sure the following conditions are met:

- The positioner is properly mounted according to the instructions.
- The pneumatic and electrical connections have been performed according to the instructions.

NOTICE

Risk of malfunction due to incorrect sequence of mounting, installation and start-up.





→ Observe the following sequence.

1. Remove the protective caps from the pneumatic connections.
2. Mount the positioner on the valve.
3. Connect the supply air.
4. Connect the electrical power.
5. Perform settings.

Once the mounting and start-up activities have been completed, you can start with the settings (see Chapter 7.2). The positioner can be operated immediately after the electrical power supply (mA control signal) has been connected.

7.1 First start-up

After the TROVIS 3730-3 Positioner is put into operation for the first time after shipment, the wizard starts automatically after the electrical power is connected. It assists users to set the display's reading direction and the menu language (English upon first start-up). The reading direction of the display depends on the mounting position (position of the rotary pushbutton, right or left of the display).

1. Turn : determine the display's reading direction.
2. Press  twice: confirm reading direction.
3. Turn : select language.
4. Press  three times: confirm language.

→ Afterwards, the display automatically changes to the main display (see the 'Operation' chapter).

→ When **ESC** is selected in the wizard, you can navigate through the displays of the wizard 1/3 (mounting position), 2/3 (language) and 3/3 (exit wizard) by selecting forward (➤) and back (◀).

→ If no settings are entered within five minutes, the positioner automatically returns to the main display.

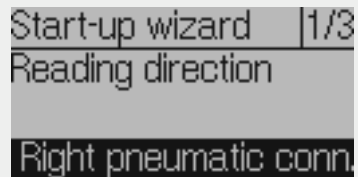







7.2 Start-up settings

→ Perform the start-up settings, keeping the following sequence:

Action	Chapter
1. Enable configuration	7.3
2. Select 'Start-up' menu	7.4
3. Set the actuator type	7.4.1
4. Determining the fail-safe position	7.4.2
5. Specify pin position	7.4.3
6. Setting the nominal range	7.4.4
7. Select initialization mode	7.4.5
8. Set initialization mode	7.4.6
9. Initialize the positioner	7.5



7.3 Enabling configuration to change parameters

1. Press  (in start screen) to change to the **main menu**.
 2. Turn  until **User level [6]** appears
(**On-site: read**) appears in this case when the enable configuration function is deactivated).
 3. Press and turn  until **On-site: write** appears.
 4. Press  to confirm.
 5. Keep  pressed down for two seconds to return to the start screen.
- Configuration is enabled. The write protection icon  is not displayed.

i Note

Configuration is locked again if no settings are entered within 5 min.



7.4 Start-up menu

1. Press  (in start screen) to change to the **main menu**.
2. Turn  until **Start-up [7]** appears.
3. Press  to go to the **Start-up** menu.

7.4.1 Setting the actuator type

Three different parameters are available for selection:

- Linear actuator
- Rotary actuator
- Linear actuator (expert) with separate setting options for pin position and nominal range

1. Turn  (within **Start-up [7]** menu) until **Actuator [7.1]** appears.
2. Press and turn  to set the actuator type.
3. Press  to confirm the setting.

7.4.2 Determining the fail-safe position

Define the fail-safe position of the valve taking the valve type and the actuator's direction of action into account. Position the AIR TO OPEN/AIR TO CLOSE slide switch accordingly:



Fail-safe position	Description
Switch setting: AIR TO OPEN	Signal pressure opens the valve, e.g. for a fail-close valve
Switch setting: AIR TO CLOSE	Signal pressure closes the valve, e.g. for a fail-open valve

For checking purposes: after initialization is completed, the positioner display must read 0 % when the valve is closed. If this is not the case, change the slide switch position and re-initialize the positioner.

7.4.3 Specifying the pin position

The setting options depend on the entered actuator type:

- For linear actuator: **Pin position [7.2]** 'None', 17, 25, 35, 50, 70, 100, 200 or 300 mm
- For rotary actuator: **Pin position [7.3]**: 90°
- For linear actuator (expert): **Pin position [7.4]**: 10 to 655 mm



1. Turn  (within **Start-up [7]** menu) until **Pin position [7.2/7.3/7.4]** appears.
2. Press and turn  to enter the pin position to match how the actuator is mounted.
3. Press  to confirm the setting.

i Note

A pin position needs to be entered for the **NOM** and **SUB** initialization modes. See Chapter 7.4.6.

7.4.4 Setting the nominal range

The possible adjustment range depends on the entered pin position.

1. Turn  (within **Start-up [7]** menu) until **Nominal range [7.5/7.6/7.7]** appears.
2. Press and turn  to set the nominal range.
3. Press  to confirm the setting.

i Note

If no pin position has been entered, **Nominal range** is only available for the **Linear actuator (expert)** actuator type.

7.4.5 Selecting the initialization mode

During initialization the positioner adapts itself optimally to the friction conditions and the signal pressure required by the control valve. The type and extent of autotuning depends on the initialization mode selected. The following initialization modes are available:

MAX: Maximum range

The positioner determines travel/angle of rotation of the closing member from the CLOSED position to the opposite travel stop and adopts this travel/angle of rotation as the operating range from 0 to 100 %.

NOM: Nominal range · Initialization mode for all globe valves

The calibrated sensor allows the exact valve travel to be measured very accurately. During initialization, the positioner checks whether the control valve can move through the indicated nominal range (travel or angle) without collision. If this is the case, the indicated nominal range is adopted as the operating range.

MAN: Manually selected end positions · Initialization mode for globe valves

Before starting initialization, move the control valve manually to the end positions. The positioner calculates the travel/angle difference from the two positions that the valve moved to and adopts it as the operating range. This initialization mode can only be started when the valve position differs in the end positions and the positioner has not yet been initialized.

SUB: Substitute calibration · To replace a positioner while the plant is running

A complete initialization procedure takes several minutes and requires the valve to move through its entire travel range several times. In the SUB initialization mode, the control parameters are estimated and not determined by an initialization procedure. As a result, a high level of accuracy cannot be expected. A different initialization mode should be selected if the plant allows it.

The substitute calibration is used to replace a positioner while the process is running. For this purpose, the control valve is usually blocked mechanically in a certain position or pneumatically by means of a pressure signal which is routed to the actuator externally. The blocking position ensures that the plant continues to operate with this valve position. The blocking position can also be the fail-safe position when this condition is beneficial for the temporary phase.



Perform a reset before re-initializing the positioner if the substitute positioner has already been initialized (see the 'Operation' chapter).

7.4.6 Setting the initialization mode

i Note

Configuration is locked again if no settings are entered within 5 min. Enable configuration: see 7.3.

Setting the **MAX** and **NOM** initialization modes:

1. Turn  (within **Start-up [7]** menu) until **Initialization mode [7.10]** appears.
2. Press and turn  to set the **MAX** or **NOM** initialization mode.
3. Press  to confirm the setting.







i Note

A pin position needs to be entered for the **NOM** initialization mode. See Chapter 7.4.3.







Setting the **MAN** initialization mode

i Note

The **MAN** initialization mode can only be started when the valve position differs in the end positions and the positioner has not yet been initialized.

1. Turn  (within **Start-up [7]** menu) until **Initialization mode [7.10]** appears.
2. Press and turn  to set the **MAN** initialization mode.
3. Press  to confirm the setting.
4. Turn  until **Set point (open-loop control) [7.14]** appears.
5. Press and turn  to move the valve to the first end position. Enter a value from -34.0 to $+34.0^\circ$.
6. Press  to confirm the value (first end position).







Start-up and configuration







7. Turn  until **Adopt valve position 1 [7.15]** appears.
8. Press  to confirm the entered first valve position as valve position 1.
9. Turn  until **Set point (open-loop control) [7.14]** appears.
10. Press and turn  to move the valve to the second end position. Enter a value from -34.0 to $+34.0^\circ$.
11. Press  to confirm the value (second end position).
12. Turn  until **Adopt valve position 2 [7.17]** appears.
13. Press  to confirm the entered second valve position as valve position 2.

Setting the SUB initialization mode

Note

The **SUB** initialization mode is a substitute calibration, which can be selected to replace a positioner while the process is running. In this mode, the control parameters are estimated and not determined by an initialization procedure. As a result, a high level of accuracy cannot be expected. A different initialization mode should be selected if the plant allows it. The **SUB** initialization mode can only be started when the positioner has not yet been initialized.

1. Write down the current valve position in %.
2. Turn  (within **Start-up [7]** menu) until **Initialization mode [7.10]** appears.
3. Press and turn  to set the **SUB** initialization mode.
4. Press  to confirm the setting.
5. Turn  until **Pin position [7.2/7.3/7.4]** appears.
6. Press and turn  to enter the pin position to match how the actuator is mounted.
7. Press  to confirm the setting.

8. Turn  until **Nominal range [7.5/7.6/7.7]** appears.
9. Press and turn  to set the actuator's nominal range.
10. Press  to confirm the setting.
11. Turn  until **Current valve position [7.19]** appears.
12. Press and turn  to set the current valve position in % (see step 1), at which the valve is currently blocked.
13. Turn  until **Direction of rotation [7.20]** appears.
14. Press and turn  to set the direction of rotation so that the lever's direction of rotation matches the valve's closing direction.

Example:

The valve closes when the plug stem moves downward. This action causes the positioner's lever to turn counterclockwise (when looking at the display).

→ Setting: Counterclockwise

i Note

After performing the SUB initialization, the control parameters can be changed (**Configuration [8]/Control parameters [8.4]**, see Appendix A).

7.5 Initializing the positioner

→ For positioners with optional limit contacts, read Chapter 7.6 before initializing the positioner.

Once all settings have been made according to Chapter 7.4, the positioner initialization can be started.

WARNING

Risk of injury by exposed moving parts on the positioner, actuator or valve.

→ Do not touch or block exposed moving parts.



NOTICE

The process is disturbed by the movement of the actuator or valve.

→ Do not perform the initialization while the process is running. First isolate the plant by closing the shut-off valves.

Note

The initialization can only be started over the menu after configuration has been enabled.

1. Turn  (within **Start-up [7] menu**) until **Start initialization [7.21]** appears.
2. Press  to start initialization.
3. Confirm warning with OK.
4. Wait until the initialization process is completed.

After initialization, the positioner remains in the **Start initialization [7.21]** menu item.

→ Keep  pressed down for two seconds to return to the **main menu**.

→ Keep  pressed down again for two seconds to return to the start screen.

→ **The positioner is ready for use.**

Tip

Initialization can also be started by pressing the initialization key (INIT). See the 'Operation' chapter.

7.6 Adjusting the switching points

The switching points of the limit switches are usually adjusted so that a signal is issued in the travel/angle end positions. Optionally, the switching point can also be adjusted to any position within the travel/angle range, e.g. if an intermediate position is to be indicated.

Both switching points are adjusted at two adjustment screws on the top of the rotary knob:

- Limit contact 1: adjustment screw 1
- Limit contact 2: adjustment screw 2

The adjustment screws are marked: **I** for adjustment screw 1 and **II** for adjustment screw 2.

The following applies to all adjustments:

- Always move the valve to the switching point from the mid-position (50 %) on adjusting or checking the switching point.
- To guarantee the switching under all ambient conditions, adjust the switching point approx. 5 % before the mechanical stop (OPEN/CLOSED).
- Contact functions:
 - Tag leaving the field: contact is closed
 - Tag entering the field: contact is opened

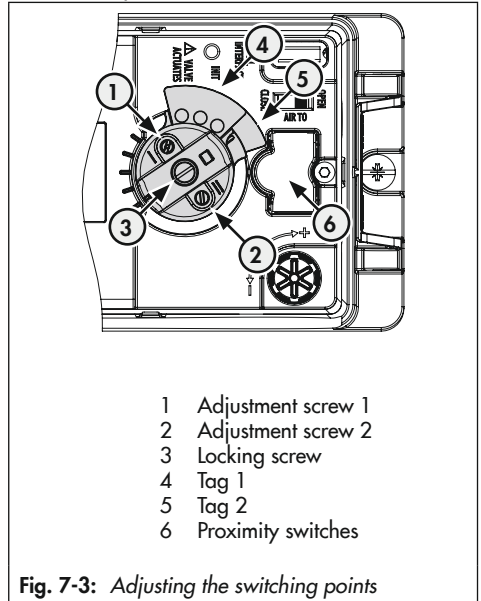

Fig. 7-3: Adjusting the switching points

7.6.1 Adjusting the CLOSED position

1. Initialize the positioner (see Chapter 7.5).
2. Move the valve using the manual mode (see the 'Operation' chapter) to 5 % (read the value off the display).
3. Undo the locking screw (3).
4. Turn the adjustment screws to adjust the tags until they leave or enter the field causing the switching amplifier to respond. You can measure the switching voltage for checking purposes.
5. Keep hold of the rotary knob and tighten the locking screw (3) (tightening torque 1.1 ± 0.1 Nm).
6. Move the valve away from the switching position and check whether the output signal changes.
7. Move the valve back to the switching position and check the switching point.

7.6.2 Adjusting the OPEN position

1. Initialize the positioner (see Chapter 7.5).
2. Move the valve using the manual mode (see the 'Operation' chapter) to 95 % (read the value off the display).
3. Undo the locking screw (3).
4. Turn the adjustment screws to adjust the tags until they leave or enter the field causing the switching amplifier to respond. You can measure the switching voltage for checking purposes.
5. Keep hold of the rotary knob and tighten the locking screw (3) (tightening torque 1.1 ± 0.1 Nm).
6. Move the valve away from the switching position and check whether the output signal changes.
7. Move the valve back to the switching position and check the switching point.

8 Operation

The work described in this chapter is only to be performed by personnel appropriately qualified to carry out such tasks.

⚠ DANGER

Risk of fatal injury due to the ignition of an explosive atmosphere.

- Observe EN 60079-14 (VDE 0165, Part 1) for work on the positioner in potentially explosive atmospheres.
- Work in potentially explosive atmospheres must only be performed by personnel who has undergone special training or instructions or who is authorized to work on explosion-protected devices in hazardous areas.



⚠ WARNING

Crush hazard arising from moving parts on the valve.

- Do not touch any moving valve parts while the control valve is in operation.
- Before performing any mounting or installation work on the positioner, put the control valve out of operation by disconnecting and locking the supply air and control signal.
- Do not impede the movement of the actuator and plug stem by inserting objects into the yoke.

8.1 Changing the reading direction of the display

The reading direction of the display can be adapted to the mounting situation (turned 180°) at any time.

1. Press  (in start screen) to change to the **main menu**.
2. Turn  until **Change reading direction [5]** appears.
3. Press  to change reading direction.

8.2 HART® communication

Conditions for HART® communication:

- Supply the positioner with at least 3.6 mA.
- Connect the FSK modem in parallel to the current loop.

A DTM file (Device Type Manager) conforming to the Specification 1.2 is available for communication. This allows the device, for example to be run with the PACTware user interface. All the positioner's parameters are accessible over the DTM and the user interface.

- For start-up, first proceed as described in the 'Start-up and configuration' chapter.

i Note

*If complex functions are started in the positioner, which require a long calculation time or lead to a large quantity of data being saved in the volatile memory of the positioner, the alert 'busy' is issued by the DTM file. This alert is **not an error message** and can be simply confirmed.*

Locking HART® communication

The write access for HART® communication can be locked. This function can be enabled or disabled locally at the positioner (**Configuration [8]/HART communication [8.3]/Locked [8.3.1]**) (setting options: Yes/No, default setting: No, see parameter list in Appendix A).

Locking on-site operation

The on-site operation can be locked over HART® communication. This locking function can only be disabled over HART® communication. On-site operation is enabled by default.

i Note

The access over TROVIS-VIEW is also locked through the locking of on-site operation over HART® communication.

8.2.1 Dynamic HART® variables

The HART® specification defines four dynamic variables consisting of a value and an engineering unit. These variables can be assigned to device parameters as required. The universal HART® command 3 reads the dynamic variables out of the device. This allows manufacturer-specific parameters to also be transferred using a universal command.

In the TROVIS 3730-3 Positioner, the dynamic variables can be assigned as follows in the Configuration folder (> HART communication):



Table 8-1: *Dynamic HART® variables assignment*

Variable	Unit, description
Set point at the input	%
Valve position	%
Error signal	%
Status messages	Current state active/not active
Option A: binary input	Current state active/not active ¹⁾
Option B: binary input	Current state active/not active ¹⁾
Total valve travel	Current total valve travel
PST outcome	Not performed/successful/test-specific error message
FST outcome	Not performed/successful/test-specific error message
Discrete valve position	Positioner not initialized, Closed, Open, Intermediate position
Current temperature	Reading of current temperature

¹⁾ Parameter assessment depends on the optional equipment used in the positioner

8.3 Changing operating mode

After initialization has been completed successfully, the positioner is in automatic mode (**AUTO**). Switchover from automatic to manual mode (**MAN**) is buttonless.

1. Press  (in start screen) to change to the **main menu** (**Target mode** menu is displayed).
2. Press  again. Turn to set the target mode (**AUTO/SAFE/MAN**).
3. Press  to confirm.

8.4 Performing zero calibration

WARNING

Risk of personal injury due to moving parts on the valve.

- *During zero calibration, do not insert hands or fingers into the valve yoke and do not touch any moving valve parts.*
- *Do not block the actuator stem.*

In case of inconsistencies in the closed position of the valve, e.g. with soft-seated plugs, it might be necessary to recalibrate zero. During zero calibration, the valve moves once to the closed position.

WARNING

Risk of injury by exposed moving parts on the positioner, actuator or valve.

- *Do not touch or block exposed moving parts.*



NOTICE

The process is disturbed by the movement of the actuator or valve.

- *Do not perform the zero calibration while the process is running. First isolate the plant by closing the shut-off valves.*

i Note

A zero calibration is not possible if there is zero point shift of more than 5 %.

1. Turn  (within **Start-up [7]** menu) until **Start zero calibration [7.22]** appears.
2. Press  to start zero calibration.
3. Confirm warning with OK.
4. Wait until zero calibration is completed.

After zero calibration, the positioner remains in the **Start zero calibration [7.22]** menu item.

→ Keep  pressed down for two seconds to return to the **main menu**.

→ Keep  pressed down again for two seconds to return to the start screen.

8.5 Resetting the positioner

! NOTICE

The process is disturbed by the movement of the actuator stem.

→ *Do not reset the positioner while the process is running. First isolate the plant by closing the shut-off valves.*

A reset allows the positioner to be reset to the default settings. The TROVIS 3730-3 Positioner has the reset options listed in Table 8-2:





1. Turn  (within **main menu**) until **Reset functions [11]** appears.
2. Press  to go to the menu.
3. Turn  to select a reset function.
4. Press  to perform the reset function.
5. Confirm warning with OK.
6. Wait until the reset function is completed.

Table 8-2: Reset function

Reset function	Description	Example
Reset diagnosis	Resets all diagnostic functions including graphs and histograms.	Diagnosis analyses of operating hours in the past are no longer relevant.
Reset (standard)	Resets the positioner to the state as upon delivery. Actuator and valve-specific settings remain unchanged. Configuration settings of the diagnostics are reset.	The attachment situation has changed. The valve has been repaired or modified. The positioner diagnosis data are no longer relevant. The positioner must be re-initialized.
Reset (advanced)	All parameters will be reset to their defaults adjusted upon delivery.	Positioner is mounted on another actuator/valve.
Restart	The positioner is shut down and restarted.	Putting the valve back into operation after a malfunction
Reset initialization	All parameters for the start-up settings are reset. The positioner needs to be re-initialized afterwards.	Changes to the start-up settings are necessary.

9 Malfunctions

⚠ DANGER

Risk of fatal injury due to the ignition of an explosive atmosphere.

- Observe EN 60079-14 (VDE 0165, Part 1) for work on the positioner in potentially explosive atmospheres.
- Work in potentially explosive atmospheres must only be performed by personnel who has undergone special training or instructions or who is authorized to work on explosion-protected devices in hazardous areas.

⚠ DANGER

Risk of bursting in the pneumatic actuator due to the use of fail-in-place module.

Before working on the positioner, actuator or any other valve accessories:

- Depressurize all plant sections concerned and the actuator. Release any stored energy.

⚠ WARNING

Crush hazard arising from actuator and plug stem moving.

- Do not insert hands or finger into the yoke while the air supply is connected to the positioner.
- Before working on the positioner, disconnect and lock the pneumatic air supply.
- Do not impede the movement of the actuator and plug stem by inserting objects into the yoke.

⚠ WARNING

Intrinsic safety rendered ineffective in intrinsically safe devices.

- Only connect intrinsically safe devices intended for use in intrinsically safe circuits to certified intrinsically safe input-connected units.
- Do not place intrinsically safe devices back into operation that were connected to intrinsically safe input-connected units without certification.
- Do not exceed the maximum permissible electric values specified in the EC type examination certificates when interconnecting intrinsically safe electrical equipment (U_i or U_0 , I_i or I_0 , P_i or P_0 , C_i or C_0 and L_i or L_0).

⚠ WARNING

Sudden loud noise when the pneumatic actuator vents.

- Wear hearing protection when working near the valve.

Malfunctions are indicated on the display by error messages in conjunction with an icon for status classification (see Table 9-1) and an error ID. Table 9-2 lists possible error messages and recommended action.

i Note

Contact SAMSON's After-sales Service for malfunctions not listed in the table. The status classification of error messages can be changed in SAMSON's TROVIS-VIEW software.

Table 9-1: Icon showing status classification

















































Icon	Meaning
	Failure
	Function check
	Out of specification
	Maintenance demanded
	No message

Table 9-2: Troubleshooting



Error ID	Status	Message	Recommended action/description
1		Init: rated travel not achieved	→ Check positioner attachment, pin position and supply pressure.
2		Init: travel too small	→ Check positioner attachment, pin position and supply pressure.
3		Init: no movement	→ Check positioner mounting, pin position and supply air. Check piping and configuration of the mounting parts. Move the positioner out of the fail-safe position.
21		Init: pin position	→ Check pin position.
26		Timeout for detection of zero	→ Zero calibration took too long. Check supply pressure and positioner attachment.
27		Positioner not initialized	→ Perform an initialization.
29		Fail-safe position mode	→ Change operating mode if no error exists.
32		Init: canceled externally	→ Check power supply/electrical signal.
36		Zero shift too large	→ The difference to the previous zero point is too large. Check the supply pressure and positioner attachment.
50		PST: start criteria not met	→ Check the positioner configuration.
51		PST: cancellation criteria met	→ Positioner configuration. Check valve and positioner attachment.
56		FST: start criteria not met	→ Check the positioner configuration.
57		FST: cancellation criteria met	→ Positioner configuration. Check valve and positioner attachment.
144		Temperature inside device below min. limit	→ Check the ambient temperature.
145		Temperature inside device above max. limit	→ Check the ambient temperature.

Malfunctions

Error ID	Status	Message	Recommended action/description
146		Test in progress	The positioner is in the test mode (e.g. initializing process, step response test etc.). → Wait until the test is completed or cancel it.
148		IP shutdown	→ Check power supply/electrical signal.
149		Brownout	→ Check power supply/electrical signal.
150		Operating mode not AUTO	The positioner is in an operating mode other than AUTO. An error does not exist.
153		Current too low	→ Check power supply/electrical signal.
154		Current too high	→ Check power supply/electrical signal.
155		Dynamic stress factor exhausted.	→ We advise ordering the spare part soon.
156		Limit for total valve travel exceeded	→ Check the control valve to ensure it functions properly.
157		Forced venting function	→ Check supply voltage. Search for the reason why the forced venting was triggered.
160		Binary input option A active	→ Reading matches the configuration of optional additional function.
161		Binary input option B active	→ Reading matches the configuration of optional additional function.
162		Combination of options invalid	→ Remove or exchange option, if necessary.
194		Set point deviation	→ Check positioner attachment and supply pressure.
195		Lower end position shifted	→ Check seat and plug.
196		Upper end position shifted	→ Check seat and plug.
198		AMR signal outside range	→ Check positioner attachment. An external malfunction or a hardware error may possibly exist.
201		Switch position for forced venting function incorrect	→ Set correct switch position.

Error ID	Status	Message	Recommended action/description
211		Emergency mode active	→ Check travel measurement.
215		Logging suspended	→ Briefly, the data volume was too high to process.
221		External position sensor error	→ Check sensor and sensor lead for possible defects.
222		Working range in closed position	→ Check positioner attachment and valve. The working range may have shifted and is close to the end position.
223		Working range in max. OPEN position	→ Check positioner attachment and valve. The working range may have shifted and is close to the end position.
224		Shifting working range: operating range is shifting towards the minimum OPEN position	→ Check positioner attachment and valve. The operating range may have shifted.
225		Shifting working range: operating range is shifting towards the maximum OPEN position	→ Check positioner attachment and valve. The operating range may have shifted.
226		Limited working range: lower range	→ Check supply pressure, positioner attachment and valve. There may be leakage or a blockage.
227		Limited working range: upper range	→ Check supply pressure, positioner attachment and valve. There may be leakage or a blockage.
2641		Init: canceled (control accuracy)	→ Check positioner attachment, pin position and supply air. Re-initialize the positioner. Possibly use a screw restriction.
2644		Init: low control accuracy	→ Check positioner attachment, pin position and supply air. Re-initialize the positioner. Possibly use a screw restriction.

Malfunctions

Error ID	Status	Message	Recommended action/description
2643		Init: angle limitation	→ Check positioner attachment, lever and pin position.
2645		Init.: timeout	→ Check positioner mounting, pin position and supply air. Check piping and configuration of the mounting parts.

Further troubleshooting

Description of fault	Measures
No reading on the display	<ul style="list-style-type: none">→ Check electrical connection and power supply.→ Check the ambient temperature (the display's operating range is from -30 to +65 °C).
Actuator moves too slowly	<ul style="list-style-type: none">→ Check the supply pressure.→ Correct setting for filter (transit time).→ Check the cross-section of the piping and screw fittings.→ Check the configuration of the mounting parts.
Actuator moves in the wrong direction.	<ul style="list-style-type: none">→ Check the characteristic setting.→ Check piping.→ Check the configuration of the mounting parts.
Air leaks from the positioner.	<ul style="list-style-type: none">→ Check seals.
Limit switch does not work properly	<ul style="list-style-type: none">→ Check the mounting and cabling.→ Check polarity of signal wires.

9.1 Emergency action

Upon failure of the air supply or electric signal, the positioner vents the actuator, causing the valve to move to the fail-safe position determined by the actuator. Plant operators are responsible for emergency action to be taken in the plant.



Tip

Emergency action in the event of valve failure is described in the associated valve documentation.

10 Servicing

The work described in this chapter is only to be performed by personnel appropriately qualified to carry out such tasks.

⚠ DANGER

Risk of fatal injury due to the ignition of an explosive atmosphere.

- Observe EN 60079-14 (VDE 0165, Part 1) for work on the positioner in potentially explosive atmospheres.
- Work in potentially explosive atmospheres must only be performed by personnel who has undergone special training or instructions or who is authorized to work on explosion-protected devices in hazardous areas.

⚠ WARNING

Crush hazard arising from actuator and plug stem moving.

- Do not insert hands or finger into the yoke while the air supply is connected to the positioner.
- Before working on the positioner, disconnect and lock the pneumatic air supply.
- Do not impede the movement of the actuator and plug stem by inserting objects into the yoke.

⚠ WARNING

Intrinsic safety rendered ineffective in intrinsically safe devices.

- Only connect intrinsically safe devices intended for use in intrinsically safe circuits to certified intrinsically safe input-connected units.
- Do not place intrinsically safe devices back into operation that were connected to intrinsically safe input-connected units without certification.
- Do not exceed the maximum permissible electric values specified in the EC type examination certificates when interconnecting intrinsically safe electrical equipment (U_i or U_{0i} , I_i or I_{0i} , P_i or P_{0i} , C_i or C_0 and L_i or L_0).

⚠ WARNING

Sudden loud noise when the pneumatic actuator vents.

- Wear hearing protection when working near the valve.

The positioner was checked by SAMSON before it left the factory.

- The product warranty becomes void if service or repair work not described in these instructions is performed without prior agreement by SAMSON's After-sales Service.
- Only use original spare parts by SAMSON, which comply with the original specifications.

10.1 Cleaning the cover window

The window is made of Makrolon® and will be damaged when cleaned with abrasive cleaning agents or agents containing solvents. To avoid damage:

- Do not rub the window dry.
- Do not use any cleaning agents containing chlorine or alcohol or abrasive cleaning agents.
- Use a non-abrasive, soft cloth for cleaning.

10.2 Firmware updates





Contact your local SAMSON engineering and sales office or subsidiary (▶ www.samsongroup.com > About SAMSON > Sales offices) to request a firmware update.

Required specifications

Please submit the following details on requesting a firmware update:

- Type
- Serial number
- Configuration ID
- Current firmware version
- Required firmware version

Table 10-1: *Recommended inspection and testing*

Inspection and testing	Action to be taken in the event of a negative result
Check the markings, labels and nameplates on the positioner for their readability and completeness.	Contact SAMSON when nameplates or labels are damaged, missing or incorrect to renew them.
	Clean any inscriptions that are covered with dirt and are illegible.
Check the positioner to ensure that it is mounted firmly.	Tighten the any loose mounting screws.
Check the pneumatic connections.	Tighten any loose male connectors of the screw fittings.
	Renew any air pipes or hoses that leak.
Check the power supply wires.	Tighten any loose cable glands.
	Make sure that the stranded wires are pushed into the terminals and tighten any loose screws on the the terminals.
	Renew damaged lines.
Check error messages on the display (indicated by the  ,  ,  and  icons).	Troubleshooting (see the 'Malfunctions' chapter).

10.3 Periodic inspection and testing of the positioner

We recommend inspection and testing according to Table 10-1 at the minimum.

11 Decommissioning

The work described in this chapter is only to be performed by personnel appropriately qualified to carry out such tasks.

⚠ DANGER

Risk of fatal injury due to the ignition of an explosive atmosphere.

- *Observe EN 60079-14 (VDE 0165, Part 1) for work on the positioner in potentially explosive atmospheres.*
 - *Work in potentially explosive atmospheres must only be performed by personnel who has undergone special training or instructions or who is authorized to work on explosion-protected devices in hazardous areas.*
-

⚠ WARNING

Sudden loud noise when the pneumatic actuator vents.

- *Wear hearing protection when working near the valve.*
-

ⓘ NOTICE

The process is disturbed by interrupting closed-loop control.

- *Do not mount or service the positioner while the process is running and only after isolating the plant by closing the shut-off valves.*
-

To decommission the positioner, proceed as follows:

1. Disconnect and lock the air supply and signal pressure.
2. Open the positioner cover and disconnect the wires for the control signal.

12 Removal

The work described in this chapter is only to be performed by personnel appropriately qualified to carry out such tasks.

DANGER

Risk of fatal injury due to the ignition of an explosive atmosphere.

- *Observe EN 60079-14 (VDE 0165, Part 1) for work on the positioner in potentially explosive atmospheres.*
 - *Work in potentially explosive atmospheres must only be performed by personnel who has undergone special training or instructions or who is authorized to work on explosion-protected devices in hazardous areas.*
-

1. Put the positioner out of operation (see the 'Decommissioning' chapter).
2. Disconnect the wires for the control signal from the positioner.
3. Disconnect the lines for supply air and signal pressure (not required for direct attachment using a connection block).
4. To remove the positioner, loosen the two fastening screws on the positioner.

13 Repairs

A defective positioner must be repaired or replaced.

⚠ NOTICE

Risk of positioner damage due to incorrect service or repair work.

- Do not perform any repair work on your own.
- Contact SAMSON's After-sales Service for repair work.

13.1 Servicing explosion-protected devices

If a part of the device on which the explosion protection is based needs to be serviced, the device must not be put back into operation until a qualified inspector has assessed it according to explosion protection requirements, has issued an inspection certificate, or given the device a mark of conformity. Inspection by a qualified inspector is not required if the manufacturer performs a routine test on the device before putting it back into operation and the passing of the routine test is documented by attaching a mark of conformity to the device. Replace explosion-protected components only with original, routine-tested components by the manufacturer.

Devices that have already been operated outside hazardous areas and are intended for future use inside hazardous areas must comply with the safety requirements placed on serviced devices. Before being operated inside hazardous areas, test the devices according to the specifications for servicing explosion-protected devices.

13.2 Returning devices to SAMSON

Defective positioners can be returned to SAMSON for repair.

Proceed as follows to return devices to SAMSON:

1. Put the positioner out of operation (see the 'Decommissioning' chapter).
2. Remove the positioner (see the 'Removal' chapter).
3. Proceed as described on the Returning goods page of our website
▶ www.samsongroup.com > Service > After-sales Service > Returning goods

14 Disposal



We are registered with the German national register for waste electric equipment (stiftung ear) as a producer of electrical and electronic equipment, WEEE reg. no.: DE 62194439

- Observe local, national and international refuse regulations.
- Do not dispose of components, lubricants and hazardous substances together with your other household waste.

**Tip**

On request, we can appoint a service provider to dismantle and recycle the product.

15 Certificates

The following certificates are included on the next pages:

- EU declaration of conformity for TROVIS 3730-3
- EU declaration of conformity for TROVIS 3730-3-110, -510, -810
- EU declaration of conformity for TROVIS 3730-3-850
- TR CU certificate for TROVIS 3730-3
- Declaration according to TR CU 020/2011 for TROVIS 3730-3
- EU type examination certificate for TROVIS 3730-3-110, -510, -810
- Statement of conformity for TROVIS 3730-3-850
- FM approvals
- IECEx certificate for TROVIS 3730-1-111, -511, -811, -851
- TR-CU Ex certificate for TROVIS 3730-3-113
- UKEX certificate for TROVIS 3730-1-118, -518
- UKEX certificate for TROVIS 3730-1-858

The certificates shown were up to date at the time of publishing. The latest certificates can be found on our website:

▶ www.samsunggroup.com > Products > Valve accessories > TROVIS 3730-3



EU Konformitätserklärung / EU Declaration of Conformity / Déclaration UE de conformité

Die alleinige Verantwortung für die Ausstellung dieser Konformitätserklärung trägt der Hersteller/
This declaration of conformity is issued under the sole responsibility of the manufacturer/
La présente déclaration de conformité est établie sous la seule responsabilité du fabricant.
Für das folgende Produkt / For the following product / Nous certifions que le produit

Elektropneumatischer Stellungsregler mit HART Kommunikation / Electropneumatic Positioner with HART communication / Positionneur électropneumatique avec communication HART TROVIS 3730-3-...

wird die Konformität mit den einschlägigen Harmonisierungsrechtsvorschriften der Union bestätigt/
the conformity with the relevant Union harmonisation legislation is declared with/
est conforme à la législation d'harmonisation de l'Union applicable selon les normes:

EMC 2014/30/EU	EN 61000-6-2:2005, EN 61000-6-3:2007 +A1:2011, EN 61326-1:2013
RoHS 2011/65/EU	EN 50581:2012

Hersteller / Manufacturer / Fabricant:

SAMSON AKTIENGESELLSCHAFT
Weismüllerstraße 3
D-60314 Frankfurt am Main
Deutschland/Germany/Allemagne

Frankfurt / Francfort, 2018-11-21

Im Namen des Herstellers/ On behalf of the Manufacturer/ Au nom du fabricant.

Dr. Julian Fuchs
Zentralabteilungsleiter/Head of Department/Chef du département
Entwicklung Ventilanbaugeräte und Messtechnik
Development Valve Attachments and Measurement Technologies

Dipl.-Ing. Silke Bianca Schäfer
Total Quality Management/
Management par la qualité totale



EU Konformitätserklärung / EU Declaration of Conformity / Déclaration UE de conformité

Die alleinige Verantwortung für die Ausstellung dieser Konformitätserklärung trägt der Hersteller/
This declaration of conformity is issued under the sole responsibility of the manufacturer/
La présente déclaration de conformité est établie sous la seule responsabilité du fabricant.
Für das folgende Produkt / For the following product / Nous certifions que le produit

Elektropneumatischer Stellungsregler mit HART Kommunikation / Electropneumatic Positioner with HART communication / Positionneur électropneumatique avec communication HART TROVIS 3730-3-110..., -510..., -810...

entsprechend der EU-Baumusterprüfbescheinigung BVS 18 ATEX E 044 X ausgestellt von der/
according to the EU Type Examination BVS 18 ATEX E 044 X issued by/
établi selon le certificat CE d'essais sur échantillons BVS 18 ATEX E 044 X émis par:

DEKRA EXAM GmbH
Dinnendahlstraße 9
D-44809 Bochum

Benannte Stelle/Notified Body/Organisme notifié 0158

wird die Konformität mit den einschlägigen Harmonisierungsrechtsvorschriften der Union bestätigt/
the conformity with the relevant Union harmonisation legislation is declared with/
est conforme à la législation d'harmonisation de l'Union applicable selon les normes:

EMC 2014/30/EU	EN 61000-6-2:2005, EN 61000-6-3:2007 +A1:2011, EN 61326-1:2013
Explosion Protection 2014/34/EU	EN 60079-0:2012+A11:2013, EN 60079-11:2012, EN 60079-15:2010, EN 60079-31:2014
RoHS 2011/65/EU	EN 50581:2012

Hersteller / Manufacturer / Fabricant:

SAMSON AKTIENGESELLSCHAFT
Weismüllerstraße 3
D-60314 Frankfurt am Main
Deutschland/Germany/Allemagne

Frankfurt / Francfort, 2018-11-22

Im Namen des Herstellers/ On behalf of the Manufacturer/ Au nom du fabricant.

Dr. Julian Fuchs
Zentralabteilungsleiter/Head of Department/Chef du département
Entwicklung Ventilanbaugeräte und Messtechnik
Development Valve Attachments and Measurement Technologies

Dipl.-Ing. Silke Bianca Schäfer
Total Quality Management/
Management par la qualité totale



EU Konformitätserklärung / EU Declaration of Conformity / Déclaration UE de conformité

Die alleinige Verantwortung für die Ausstellung dieser Konformitätserklärung trägt der Hersteller/
This declaration of conformity is issued under the sole responsibility of the manufacturer/
La présente déclaration de conformité est établie sous la seule responsabilité du fabricant.
Für das folgende Produkt / For the following product / Nous certifions que le produit

Elektropneumatischer Stellungsregler mit HART Kommunikation / Electropneumatic Positioner with HART communication / Positionneur électropneumatique avec communication HART TROVIS 3730-3-850...

entsprechend der EU-Baumusterprüfbescheinigung BVS 18 ATEX E 045 ausgestellt von der/
according to the EU Type Examination BVS 18 ATEX E 045 issued by/
établi selon le certificat CE d'essais sur échantillons BVS 18 ATEX E 045 émis par:

DEKRA EXAM GmbH
Dinnendahlstraße 9
D-44809 Bochum

Benannte Stelle/Notified Body/Organisme notifié 0158

wird die Konformität mit den einschlägigen Harmonisierungsrechtsvorschriften der Union bestätigt/
the conformity with the relevant Union harmonisation legislation is declared with/
est conforme à la législation d'harmonisation de l'Union applicable selon les normes:

EMC 2014/30/EU	EN 61000-6-2:2005, EN 61000-6-3:2007 +A1:2011, EN 61326-1:2013
Explosion Protection 2014/34/EU	EN 60079-0:2012+A11:2013, EN 60079-15:2010
RoHS 2011/65/EU	EN 50581:2012

Hersteller / Manufacturer / Fabricant:

SAMSON AKTIENGESELLSCHAFT
Weismüllerstraße 3
D-60314 Frankfurt am Main
Deutschland/Germany/Allemagne

Frankfurt / Francfort, 2018-11-22

Im Namen des Herstellers/ On behalf of the Manufacturer/ Au nom du fabricant.

Dr. Julian Fuchs
Zentralabteilungsleiter/Head of Department/Chef de département
Entwicklung Ventilanbaugeräte und Messtechnik
Development Valve Attachments and Measurement Technologies

Dipl.-Ing. Silke Bianca Schäfer
Total Quality Management/
Management par la qualité totale



ЕВРАЗИЙСКИЙ ЭКОНОМИЧЕСКИЙ СОЮЗ ДЕКЛАРАЦИЯ О СООТВЕТСТВИИ

Заявитель Общество с ограниченной ответственностью "САМСОН КОНТРОЛС".

Основной государственный регистрационный номер: 1037700041026. Место нахождения и адрес места осуществления деятельности: 109544, город Москва, бульвар Энтузиастов, дом 2, этаж 5, комната 11, Российская Федерация. Телефон: +7 (495) 777-4545, адрес электронной почты: samson@samson.ru.

в лице Генерального директора Крымшамхалова Азрета Индрисовича, действующего на основании Устава.

заявляет, что **Позиционеры электропневматические с маркировкой SAMSON типов TROVIS 3730-1, TROVIS 3730-3.**

Изготовитель "SAMSON AG Mess- und Regeltechnik".

Место нахождения и адрес места осуществления деятельности по изготовлению продукции: Weismüllerstrasse 3, 60314 Frankfurt am Main, Федеративная Республика Германия.

Продукция изготовлена в соответствии с 2014/30/EU "Electromagnetic compatibility directive" (2014/30/EU "Директива по электромагнитной совместимости").

Код ТН ВЭД ЕАЭС: 9032 89 000 0.

Серийный выпуск.

соответствует требованиям ТР ТС 020/2011 "Электромагнитная совместимость технических средств".

Декларация о соответствии принята на основании эксплуатационной документации (инструкции по монтажу и эксплуатации ЕВ 8484-1 RU); протокола испытаний № 10-08-2020 от 04.08.2020, выданного Испытательной лабораторией Общества с ограниченной ответственностью "Испытательный центр".

Схема декларирования соответствия: 1д.

Дополнительная информация разделы 5 и 7 ГОСТ 30804.3.2-2013 (IEC 61000-3-2:2009) "Совместимость технических средств электромагнитная. Эмиссия гармонических составляющих тока техническими средствами с потребляемым током не более 16 А (в одной фазе). Нормы и методы испытаний", раздел 5 ГОСТ 30804.3.3-2013 (IEC 61000-3-3:2008) "Совместимость технических средств электромагнитная. Ограничение изменений напряжения, колебаний напряжения и фликера в низковольтных системах электроснабжения общего назначения. Технические средства с потребляемым током не более 16 А (в одной фазе), подключаемые к электрической сети при несоблюдении определенных условий подключения. Нормы и методы испытаний".

Условия хранения: под навесами при температуре окружающего воздуха от минус 60 °С до плюс 60 °С и относительной влажности до 70%. Назначенный срок хранения: 24 месяца. Назначенный срок службы: 15 лет.

Декларация о соответствии действительна с даты регистрации по 04.08.2020 включительно.

(подпись)



Крымшамхалов Азрет Индрисович
(Ф.И.О. заявителя)

Регистрационный номер декларации о соответствии:

ЕАЭС N RU Д-ДЕ.МХ24.В.01219/20

Дата регистрации декларации о соответствии: 05.08.2020



ЕВРАЗИЙСКИЙ ЭКОНОМИЧЕСКИЙ СОЮЗ ДЕКЛАРАЦИЯ О СООТВЕТСТВИИ

Заявитель Общество с ограниченной ответственностью "САМСОН КОНТРОЛС".
 Основной государственный регистрационный номер: 1037700041026. Место нахождения и адрес места осуществления деятельности: 109544, город Москва, бульвар Энтузиастов, дом 2, этаж 5, комната 11, Российская Федерация. Телефон: +7 (495) 777-4545, адрес электронной почты: samson@samson.ru.

в лице Генерального директора Крымшамхалова Азрета Индрисовича, действующего на основании Устава.

заявляет, что **Позиционеры электропневматические с маркировкой SAMSON типов TROVIS 3730-1, TROVIS 3730-3.**

Изготовитель "SAMSON AG Mess- und Regeltechnik".
 Место нахождения и адрес места осуществления деятельности по изготовлению продукции: Weismüllerstrasse 3, 60314 Frankfurt am Main, Федеративная Республика Германия.

Продукция изготовлена в соответствии с 2014/30/EU "Electromagnetic compatibility directive" (2014/30/EU "Директива по электромагнитной совместимости").

Код ТН ВЭД ЕАЭС: 9032 89 000 0.
 Серийный выпуск.



соответствует требованиям ТР ТС 020/2011 "Электромагнитная совместимость технических средств".

Декларация о соответствии принята на основании эксплуатационной документации (инструкции по монтажу и эксплуатации EB 8484-1 RU); протокола испытаний № 10-08-2020 от 04.08.2020, выданного Испытательной лабораторией Общества с ограниченной ответственностью "Испытательный центр".

Схема декларирования соответствия: Дд.

Дополнительная информация разделы 5 и 7 ГОСТ 30804.3.2-2013 (IEC 61000-3-2:2009) "Совместимость технических средств электромагнитная. Эмиссия гармонических составляющих тока техническими средствами с потребляемым током не более 16 А (в одной фазе). Нормы и методы испытаний", раздел 5 ГОСТ 30804.3.3-2013 (IEC 61000-3-3:2008) "Совместимость технических средств электромагнитная. Ограничение изменений напряжения, колебаний напряжения и фликера в низковольтных системах электроснабжения общего назначения. Технические средства с потребляемым током не более 16 А (в одной фазе), подключаемые к электрической сети при несоблюдении определенных условий подключения. Нормы и методы испытаний".
 Условия хранения: под навесами при температуре окружающего воздуха от минус 60 °С до плюс 60 °С и относительной влажности до 70%. Назначенный срок хранения: 24 месяца.
 Назначенный срок службы: 15 лет.

Декларация о соответствии действительна с даты регистрации по 04.08.2025 включительно.

 (подпись)  Крымшамхалов Азрет Индрисович (Ф.И.О. заявителя)

Регистрационный номер декларации о соответствии:

ЕАЭС N RU Д-ДЕ.МХ24.В.01219/20

Дата регистрации декларации о соответствии: 05.08.2020

Translation

1 **EU-Type Examination Certificate**

2 **Equipment intended for use in potentially explosive atmospheres**
Directive 2014/34/EU

3 EU-Type Examination Certificate Number: **BVS 18 ATEX E 044 X**

4 Product: **Positioner with HART® communication TROVIS 3730-3-...**

5 Manufacturer: **SAMSON AG**

6 Address: **Weismüllerstraße 3, 60314 Frankfurt am Main, Germany**

7 This product and any acceptable variations thereto are specified in the appendix to this certificate and the documents referred to therein.

8 DEKRA EXAM GmbH, Notified Body number 0158, in accordance with Article 17 of Directive 2014/34/EU of the European Parliament and of the Council, dated 26 February 2014, certifies that this product has been found to comply with the Essential Health and Safety Requirements relating to the design and construction of products intended for use in potentially explosive atmospheres given in Annex II to the Directive.

The examination and test results are recorded in the confidential Report No. BVS PP 18.2081 EU.

9 The Essential Health and Safety Requirements are assured in consideration of:

EN 60079-0:2012 + A11:2013	General requirements
EN 60079-11:2012	Intrinsic safety "i"
EN 60079-15:2010	Type of protection "n"
EN 60079-31:2014	Protection by enclosures "t"

10 If the sign "X" is placed after the certificate number, it indicates that the product is subject to the Special Conditions for Use specified in the appendix to this certificate.

11 This EU-Type Examination Certificate relates only to the design and construction of the specified product. Further requirements of the Directive apply to the manufacturing process and supply of this product. These are not covered by this certificate.

12 The marking of the product shall include the following:

-  **II 2G Ex ia IIC T4/T6 Gb** for TROVIS 3730-3-110...
-  **II 2D Ex ia IIIC T85°C Db**
-  **II 2D Ex tb IIIC T85°C Db** for TROVIS 3730-3-510...
-  **II 3G Ex nA IIC T4/T6 Gc** for TROVIS 3730-3-810...
-  **II 2D Ex tb IIIC T85°C Db**

DEKRA EXAM GmbH
 Bochum, 2018-06-07

Signed: Ralf Leiendecker

Certifier

Signed: Dr Michael Wittler

Approver



13 Appendix

14 EU-Type Examination Certificate
BVS 18 ATEX E 044 X

15 Product description

15.1 Subject and type

Positioner with HART® communication TROVIS 3730-3-*****

TROVIS 3730-3-	a	b	c	d	e	f	g	h	i	j	k	l	m	n	o	p	q	r	s	t
	a	b	c	Explosion protection																
	1	1	0	II 2G Ex ia IIC T4/T6 Gb / II 2G Ex ia IIIC T85°C Db																
	5	1	0	II 2D Ex tb IIIC T85°C Db																
	8	1	0	II 3G Ex nA IIC T4/T6 Gc / II 2D Ex tb IIIC T85°C Db																
				d Function																
				- Not relevant																
				e Slot A Option																
				0 Without																
				1 Position transmitter 4 to 20 mA																
				2 Binary input 24 V DC																
				f Slot B Option																
				0 Without																
				1 Position transmitter 4 to 20 mA																
				2 Binary input 24 V DC																
				3 Forced venting																
				g Slot C Option																
				0 Without																
				2 Software limit switches + Binary output (NAMUR)																
				3 1 x Inductive limit switches + Binary output (NAMUR)																
				4 2 x Inductive limit switches + Binary output (NAMUR)																
				5 1 x Software limit switches + 1 x Inductive limit switches + Binary output (NAMUR)																
				h Slot D Option																
				0 Without																
				1 External travel sensor with M12x1 connector, with 10 m connecting cable																
				2 External travel sensor with M12x1 connector, ready mounted																
				3 External travel sensor, 3712 housing with connector, ready mounted																
				4 External travel sensor, 3712 housing with connector with 10 m connecting cable																
				5 External travel sensor, 3712 housing with cable gland, ready mounted																
				6 External travel sensor, 3712 housing with 10 m connecting cable																
				i Reserved																
				- Not relevant																
				- Reserved																
				- Not relevant																
				k Emergency shutdown																
				- Not relevant																
				l Electrical connection																
				0 Without																
				1 Two M20x1.5, one plastic cable gland																
				2 Two M20x1.5, two metal cable glands																
				m Reserved																
				- Not relevant																
				n Housing material																
				0 Aluminium EN AC-44300DF																
				1 Stainless steel 1.4408																
				o Cover																
				1 With round window																
				2 Closed (without window)																
				p q Housing version																
				- - Not relevant																
				r Additional approval																
				- Not relevant																
				s Ship approval																
				- Not relevant																
				t Permissible ambient temperature																
				- Not relevant																

- If Slot D option 5 or 6 is configured only Slot A option 0 is permitted.
- For TROVIS 3730-3-510...: For Slot D, only options 0, 5 and 6 are permitted.
- For TROVIS 3730-3-810...: For Slot D, only option 0 is permitted.

Page 2 of 5 of BVS 18 ATEX E 044 X

This certificate may only be reproduced in its entirety and without any change.



DEKRA EXAM GmbH, Dinnendahlstrasse 9, 44809 Bochum, Germany,
telephone +49.234.3696-105, fax +49.234.3696-110, zs-exam@dekra.com

15.2 Description

The Positioner with HART® communication TROVIS 3730-3-... is a single acting positioner for attachment to pneumatic control valves.
The positioner ensures a predetermined assignment of the valve position (controlled variable x) to the input signal (reference variable w). It compares the input signal received from a control system to the travel or rotational angle of the control valve and issues a corresponding output signal pressure (output variable y) for the pneumatic actuator.

The apparatus consists of an enclosure with several fixed mounted PCBs. In addition to the power supply terminals +11 / -12 the device contains slots for different options modules. The options modules provide additional connection terminals for external circuits. The serial interface (5 pin socket) for performing a firmware update may only be used by the manufacturer.

Depending on the type of the apparatus there are different types of protection:
TROVIS 3730-3-110... has type of protection "ia" and may be used for Category 2G and 2D (Zone 1 and Zone 21).
TROVIS 3730-3-510... has type of protection "tb" and may be used for Category 2D in Zone 21.
TROVIS 3730-3-810... has type of protection "nA" and "tb" and may be used for Category 3G and 2D in Zone 2 and Zone 21.

The Options Module Code C includes a Pepperl+Fuchs inductive limit switch type S.J2-SN (Certificate: PTB 00 ATEX 2049X; standard EN 60079-0:2012-A11:2013, EN 60079-11:2012).

For TROVIS 3730-3-110... (type of protection "ia"): when using the options module Code C: Two different sets of input parameters are permissible (supply variant type 2 and type 3), if the options module is supplied with parameters type 3, the ambient temperature is limited.

15.3 Parameters

15.3.1 Electrical Parameters for TROVIS 3730-3-110

Type of protection "ia"

15.3.1.1 Signal Circuit Terminal +11 / -12

Maximum input voltage	U_i	DC	28	V
Maximum input current	I_i		115	mA
Maximum input power	P_i		1	W
Maximum internal capacitance	C_i		14.6	nF
Maximum internal inductance	L_i		negligible	

15.3.1.2 Software Limit Switches (NAMUR) Terminals +45 / -46 and +55 / -56

Maximum input voltage	U_i	DC	16	V
Maximum input current	I_i		52	mA
Maximum input power	P_i		169	mW
Maximum internal capacitance	C_i		11.1	nF
Maximum internal inductance	L_i		negligible	

15.3.1.3 Binary Output (NAMUR) Terminal +83 / -84

Maximum input voltage	U_i	DC	16	V
Maximum input current	I_i		52	mA
Maximum input power	P_i		169	mW
Maximum internal capacitance	C_i		11.1	nF
Maximum internal inductance	L_i		negligible	

15.3.1.4 Binary Input (24 V DC) Terminal +87 / -88

Maximum input voltage	U_i	DC	28	V
Maximum input current	I_i		115	mA
Maximum input power	P_i		1	W
Maximum internal capacitance	C_i		37.1	nF
Maximum internal inductance	L_i		negligible	

15.3.1.5 Position Transmitter Terminal +31 / -32

Maximum input voltage	U_i	DC	28	V
Maximum input current	I_i		115	mA
Maximum input power	P_i		1	W
Maximum internal capacitance	C_i		11.1	nF
Maximum internal inductance	L_i		negligible	

15.3.1.6 Forced Venting Terminal +81 / -82

Maximum input voltage	U_i	DC	28	V
Maximum input current	I_i		115	mA
Maximum input power	P_i		1	W
Maximum internal capacitance	C_i		11.1	nF
Maximum internal inductance	L_i		negligible	

15.3.1.7 Inductive Limit Switches Terminals +41 / -42 and +51 / -52

		Type 2	Type 3
Maximum input voltage	U_i	16 V	16 V
Maximum input current	I_i	25 mA	52 mA
Maximum input power	P_i	64 mW	169 mW
Maximum internal capacitance	C_i	41.1 nF	41.1 nF
Maximum internal inductance	L_i	100 μ H	100 μ H

15.3.2 Electrical Parameters for type of protection "Ib" and "nA"

15.3.2.1 Signal Circuit Terminal +11 / -12

Nominal input current	I_N	4	20	mA
Nominal input voltage	U_N		9.8	V
Nominal input power	P_N		212	mW

15.3.2.2 Software Limit Switches (NAMUR) Terminals +45 / -46 and +55 / -56

Nominal input voltage	U_N		8.2	V
Nominal input power	P_N		17	mW

15.3.2.3 Binary Output (NAMUR) Terminal +83 / -84

Nominal input voltage	U_N		8.2	V
Nominal input power	P_N		17	mW

15.3.2.4 Binary Input (24 V DC) Terminal +87 / -88

Nominal input voltage	U_N		24	V
Nominal input power	P_N		12	mW

15.3.2.5 Position Transmitter Terminal +31 / -32

Nominal input voltage	U_N		24	V
Nominal input power	P_N		518	mW

15.3.2.6 Forced Venting Terminal +81 / -82

Nominal input voltage	U_N		24	V
Nominal input power	P_N		173	mW

15.3.2.7 Inductive Limit Switches Terminals +41 / -42 and +51 / -52

Nominal input voltage	U_N		8.2	V
Nominal input power	P_N		17	mW

- 15.3.3 Thermal Parameters
- 15.3.3.1 For TROVIS 3730-3-110... Group II application (type of protection "ia")
- | | | |
|-------------------|----|--|
| Temperature Class | T4 | $-40\text{ }^{\circ}\text{C} \leq T_{\text{amb}} \leq +80\text{ }^{\circ}\text{C}$ |
| Temperature Class | T6 | $-40\text{ }^{\circ}\text{C} \leq T_{\text{amb}} \leq +55\text{ }^{\circ}\text{C}$ |
- Operation with Inductive Limit Switches supply variant type 3
- | | | |
|-------------------|----|--|
| Temperature Class | T4 | $-40\text{ }^{\circ}\text{C} \leq T_{\text{amb}} \leq +70\text{ }^{\circ}\text{C}$ |
| Temperature Class | T6 | $-40\text{ }^{\circ}\text{C} \leq T_{\text{amb}} \leq +45\text{ }^{\circ}\text{C}$ |
- Operation with external position sensor
- | | | |
|-------------------|----|--|
| Temperature Class | T4 | $-30\text{ }^{\circ}\text{C} \leq T_{\text{amb}} \leq +80\text{ }^{\circ}\text{C}$ |
| Temperature Class | T6 | $-30\text{ }^{\circ}\text{C} \leq T_{\text{amb}} \leq +55\text{ }^{\circ}\text{C}$ |
- 15.3.3.2 For TROVIS 3730-3-110... Group III application (type of protection "ia")
- | | | |
|-----------------------------|---------|--|
| Maximum surface temperature | T 85 °C | $-40\text{ }^{\circ}\text{C} \leq T_{\text{amb}} \leq +55\text{ }^{\circ}\text{C}$ |
|-----------------------------|---------|--|
- Operation with external position sensor
- | | | |
|-----------------------------|---------|--|
| Maximum surface temperature | T 85 °C | $-30\text{ }^{\circ}\text{C} \leq T_{\text{amb}} \leq +55\text{ }^{\circ}\text{C}$ |
|-----------------------------|---------|--|
- 15.3.3.3 For TROVIS 3730-3-510... and TROVIS 3730-3-810... (type of protection "nA" and "tb")
- | | | |
|-----------------------------|---------|--|
| Temperature Class | T4 | $-40\text{ }^{\circ}\text{C} \leq T_{\text{amb}} \leq +80\text{ }^{\circ}\text{C}$ |
| Temperature Class | T6 | $-40\text{ }^{\circ}\text{C} \leq T_{\text{amb}} \leq +55\text{ }^{\circ}\text{C}$ |
| Maximum surface temperature | T 85 °C | $-40\text{ }^{\circ}\text{C} \leq T_{\text{amb}} \leq +70\text{ }^{\circ}\text{C}$ |

16 **Report Number**

BVS PP 18.2081 EU, as of 2018-06-07

17 **Special Conditions for Use**

For TROVIS 3730-3-110...

For applications in dust group III C, the cable glands and blanking plugs supplied must be replaced with certified ones. The cable glands and blanking plugs must be suitable for the corresponding ambient temperatures and have a degree of protection of at least IP54.

18 **Essential Health and Safety Requirements**

The Essential Health and Safety Requirements are covered by the standards listed under item 9.

19 **Drawings and Documents**

Drawings and documents are listed in the confidential report.

We confirm the correctness of the translation from the German original.
In the case of arbitration only the German wording shall be valid and binding.

DEKRA EXAM GmbH
Bochum, dated 2018-06-07
BVS-Su/Nu A 20170879



Certifier



Approver

Page 5 of 5 of BVS 18 ATEX E 044 X

This certificate may only be reproduced in its entirety and without any change.



DEKRA EXAM GmbH, Dinnendahlstrasse 9, 44809 Bochum, Germany,
telephone +49.234.3696-105, fax +49.234.3696-110, zs-exam@dekra.com

Translation

1 **Type Examination Certificate**

2 Equipment intended for use in potentially explosive atmospheres
Directive 2014/34/EU

3 Type Examination Certificate Number: **BVS 18 ATEX E 045**

4 Product: **Positioner with HART® communication TROVIS 3730-3-850...**

5 Manufacturer: **SAMSON AG**

6 Address: **Weismüllerstraße 3, 60314 Frankfurt am Main, Germany**

7 This product and any acceptable variations thereto are specified in the appendix to this certificate and the documents referred to therein.

8 DEKRA EXAM GmbH certifies that this product has been found to comply with the Essential Health and Safety Requirements relating to the design and construction of products intended for use in potentially explosive atmospheres given in Annex II to the Directive.
The examination and test results are recorded in the confidential Report No. BVS PP 18 2083 EU.

9 The Essential Health and Safety Requirements are assured in consideration of:

EN 60079-0:2012 + A11:2013 General requirements
EN 60079-15:2010 Type of Protection "n"

10 If the sign "X" is placed after the certificate number, it indicates that the product is subject to the Special Conditions for Use specified in the appendix to this certificate.

11 This Type Examination Certificate relates only to the design and construction of the specified product. Further requirements of the Directive apply to the manufacturing process and supply of this product. These are not covered by this certificate.

12 The marking of the product shall include the following:

 **II 3G Ex nA IIC T4/T6 Gc**

DEKRA EXAM GmbH
Bochum, 2018-06-07

Signed: Ralf Leiendecker

Certifier

Signed: Dr Michael Wittler

Approver

Page 1 of 4 of BVS 18 ATEX E 045
This certificate may only be reproduced in its entirety and without any change.



DEKRA EXAM GmbH, Dinnendahlstrasse 9, 44809 Bochum, Germany,
telephone +49.234.3696-105, fax +49.234.3696-110, zs-exam@dekra.com

13 **Appendix**

14 **Type Examination Certificate**
BVS 18 ATEX E 045

15 **Product description**

15.1 **Subject and type**

Positioner with HART® communication TROVIS 3730-3-850*****

TROVIS 3730-3-	a	b	c	d	e	f	g	h	i	j	k	l	m	n	o	p	q	r	s	t
	a	b	c	Explosion protection																
	8	5	0	II 3G Ex nA IIC T4/T6 Gc																
				d	Function															
				-	Not relevant															
				e	Slot A Option															
				0	Without															
				1	Position transmitter 4 to 20 mA															
				2	Binary input 24 V DC															
				f	Slot B Option															
				0	Without															
				1	Position transmitter 4 to 20 mA															
				2	Binary input 24 V DC															
				3	Forced venting															
				g	Slot C Option															
				0	Without															
				2	Software limit switches + Binary output (NAMUR)															
				3	1 x Inductive limit switches + Binary output (NAMUR)															
				4	2 x Inductive limit switches + Binary output (NAMUR)															
				5	1 x Software limit switches + 1 x Inductive limit switches + Binary output (NAMUR)															
				h	Slot D Option															
				0	Without															
				1	Reserved															
				-	Not relevant															
				1	Reserved															
				-	Not relevant															
				k	Emergency shutdown															
				-	Not relevant															
				l	Electrical connection															
				0	Without															
				1	Two M20x1.5, one plastic cable gland															
				2	Two M20x1.5, two metal cable glands															
				m	Reserved															
				-	Not relevant															
				n	Housing material															
				0	Aluminium EN-AC-44300DF															
				1	Stainless steel 1.4408															
				o	Cover															
				1	With round window															
				2	Closed (without window)															
				p	Housing version															
				-	Not relevant															
				r	Additional approval															
				-	Not relevant															
				s	Ship approval															
				-	Not relevant															
				t	Permissible ambient temperature															
				-	Not relevant															

15.2 Description

The Positioner with HART® communication TROVIS 3730-3-850... is a single acting positioner for attachment to pneumatic control valves. The Positioner mainly consists of the electronics part and one pneumatic module. The parts are assembled in an enclosure made of aluminum die cast or stainless steel die cast. The enclosure has a cover with a polymeric inspection window. As an alternative to the polymeric material the lid can be made completely solid from aluminium or stainless steel. The rating of the enclosure construction is IP66. The device is built in type of protection "nA".

15.3 Parameters

Signal Circuit Terminal +11 / -12

Nominal input current	I_N	4 ... 20	mA
Nominal input voltage	U_N	9.8	V
Nominal input power	P_N	212	mW

Software Limit Switches (NAMUR) Terminals +45 / -46 and +55 / -56

Nominal input voltage	U_N	8.2	V
Nominal input power	P_N	17	mW

Binary Output (NAMUR) Terminal +83 / -84

Nominal input voltage	U_N	8.2	V
Nominal input power	P_N	17	mW

Binary Input (24 V DC) Terminal +87 / -88

Nominal input voltage	U_N	24	V
Nominal input power	P_N	12	mW

Position Transmitter Terminal +31 / -32

Nominal input voltage	U_N	24	V
Nominal input power	P_N	518	mW

Forced Venting Terminal +81 / -82

Nominal input voltage	U_N	24	V
Nominal input power	P_N	173	mW

Inductive Limit Switches Terminals +41 / -42 and +51 / -52

Nominal input voltage	U_N	8.2	V
Nominal input power	P_N	17	mW

15.3.2 Thermal Parameters

Temperature Class	T4	$-40\text{ °C} \leq T_{\text{amb}} \leq +80\text{ °C}$
Temperature Class	T6	$-40\text{ °C} \leq T_{\text{amb}} \leq +55\text{ °C}$

- 16 **Report Number**
BVS PP 18.2083 EU, as of 2018-06-07
- 17 **Special Conditions for Use**
None
- 18 **Essential Health and Safety Requirements**
The Essential Health and Safety Requirements are covered by the standards listed under item 9.
- 19 **Drawings and Documents**
Drawings and documents are listed in the confidential report.

We confirm the correctness of the translation from the German original.
In the case of arbitration only the German wording shall be valid and binding.

DEKRA EXAM GmbH
Bochum, dated 2018-06-07
BVS-Ref/Su/Nu A 20170881



Certifier



Approver

CERTIFICATE OF CONFORMITY



1. **HAZARDOUS (CLASSIFIED) LOCATION ELECTRICAL EQUIPMENT PER US REQUIREMENTS**
2. **Certificate No:** FM21US0097
3. **Equipment:** Type 3730-3 series TROVIS HART Positioner
(Type Reference and Name)
4. **Name of Listing Company:** Samson AG
5. **Address of Listing Company:** Weismuellerstrasse 3
Postfach 101901
Frankfurt D60314
Germany
6. The examination and test results are recorded in confidential report number:
PR459607 dated 18th October 2022
7. FM Approvals LLC, certifies that the equipment described has been found to comply with the following Approval standards and other documents:
FM Class 3600:2022, FM Class 3610:2021, FM Class 3611:2021, FM Class 3810:2021,
ANSI/ISA 60079-0:2020, ANSI/UL 60079-11:2018, ANSI/UL 60079-31:2015, ANSI/ISA 61010-1:2012,
ANSI/UL 121201:2019, ANSI/IEC 60529:2020, NEMA 250:2008
8. If the sign 'X' is placed after the certificate number, it indicates that the equipment is subject to specific conditions of use specified in the schedule to this certificate.

Certificate issued by:

J.E. Marquedant

J.E. Marquedant
VP, Manager - Electrical Systems

18 January 2023

Date

To verify the availability of the Approved product, please refer to www.approvalguide.com

THIS CERTIFICATE MAY ONLY BE REPRODUCED IN ITS ENTIRETY AND WITHOUT CHANGE

FM Approvals LLC, 1151 Boston-Providence Turnpike, Norwood, MA 02062 USA
T: +1 (1) 781 762 4300 F: +1 (1) 781 762 9375 E-mail: information@fmapprovals.com www.fmapprovals.com

F 347 (Apr 21)



Page 1 of 5

SCHEDULE



US Certificate Of Conformity No: FM21US0097

9. This certificate relates to the design, examination and testing of the products specified herein. The FM Approvals surveillance audit program has further determined that the manufacturing processes and quality control procedures in place are satisfactory to manufacture the product as examined, tested and Approved.

10. Equipment Ratings:

Intrinsically Safe for Class I, II, III Division 1, Groups A, B, C, D, E, F, and G hazardous (classified) locations in accordance with drawing EB 8484-3, Intrinsically Safe for Class I, Zone 1, Group IIC hazardous (classified) locations in accordance with drawing EB 8484-3; Nonincendive for Class I, II, III Division 2, Groups A, B, C, D, F and G hazardous locations, indoors and outdoors (Type 4X, IP66) with an ambient temperature rating per the table in Section 12 below

11. The marking of the equipment shall include:

IS Class I, II, III, Division 1, Groups A, B, C, D, E, F, G; T* Ta*

IS Class I, Zone 1, AEx ia IIC T* Gb

NI Class I, II, III Division 2, Groups A, B, C, D, F, G; T* Ta*

Type 4X; IP66

For Entity and NIFW parameters – refer to document no. EB8484-3

T* - See below

12. **Description of Equipment:**

General - The Type TROVIS 3730-3 HART Positioner is a single acting positioner for attachment to pneumatic control valves. The positioner ensures a predetermined assignment of the valve position (controlled variable x) to the input signal (reference variable w). It compares the input signal received from a control system to the travel or rotational angle of the control valve and issues a corresponding output signal pressure (output variable y) for the pneumatic actuator.

Construction - The Type TROVIS 3730-3 HART Positioner mainly consists of the electronics part and one pneumatic module. The parts are assembled in an enclosure made of aluminium die cast or stainless-steel die cast. The enclosure has a cover with a polymeric inspection window. As an alternative to the polymeric material the window can be made from aluminium. The enclosure has an ingress protection rating of Type 4X and IP66

THIS CERTIFICATE MAY ONLY BE REPRODUCED IN ITS ENTIRETY AND WITHOUT CHANGE

FM Approvals LLC, 1151 Boston-Providence Turnpike, Norwood, MA 02062 USA
T: +1 (1) 781 762 4300 F: +1 (1) 781 762 9375 E-mail: information@fmapprovals.com www.fmapprovals.com

F 347 (Apr 21)

Page 2 of 5

SCHEDULE



US Certificate Of Conformity No: FM21US0097

Thermal Ratings:

The correlation between temperature class and permissible ambient temperature range T_a is shown in Table 2.

Table 2:

Temperature class	Permissible ambient temperature T_a
T4	$-40\text{ °C} \leq T_a \leq +80\text{ °C}$
T6	$-40\text{ °C} \leq T_a \leq +55\text{ °C}$

For operation with inductive limit switches used with $I_{max}/I_i = 52\text{ mA}$ and $P_i = 169\text{ mW}$, the correlation between temperature class and permissible ambient temperature range is shown in Table 3.

Table 3:

Temperature class	Permissible ambient temperature T_a
T4	$-40\text{ °C} \leq T_a \leq +70\text{ °C}$
T6	$-40\text{ °C} \leq T_a \leq +45\text{ °C}$

Electrical Ratings:

Circuit	Signal circuit	Position transmitter	Inductive limit switches	Software limit switches
Circuit no.	1	2	3 and 4	5 and 6
Terminal no.	+11 / -12	+31 / -32	+41 / -42 and +51 / -52	+45 / -46 and +55 / -56
V_{max} or U_i	28 V	28 V	16 V	16 V
I_{max} or I_i	115 mA	115 mA	25 mA or 52 mA	52 mA
P_i	1 W	1 W	64 mW or 169 mW	169 mW
C_i	16.3 nF	11.1 nF	71.1 nF	12.2 nF
L_i	negligible	negligible	100 μ H	negligible
Rated values	$I_N = 4\text{ mA} \dots 20\text{ mA}$	$U_N = 24\text{ V DC}$	* $U_N = 8.2\text{ V}$ $R_i = 1\text{ k}\Omega$	* $U_N = 8.2\text{ V}$ $R_i = 1\text{ k}\Omega$
Circuit	External position sensor	Forced venting	Binary output (NAMUR)	Binary input (24 V DC)
Circuit no.	7	8	9	10
Terminal no.	V_REF / PISTE / GND	+81 / -82	+83 / -84	+87 / -88
V_{max} or U_i	4.8 V	28 V	16 V	28 V
I_{max} or I_i	64 mA	115 mA	52 mA	115 mA

THIS CERTIFICATE MAY ONLY BE REPRODUCED IN ITS ENTIRETY AND WITHOUT CHANGE

FM Approvals LLC, 1151 Boston-Providence Turnpike, Norwood, MA 02062 USA
 T: +1 (1) 781 762 4300 F: +1 (1) 781 762 9375 E-mail: information@fmaprovals.com www.fmaprovals.com

SCHEDULE



US Certificate Of Conformity No: FM21US0097

P_i	74 mW	1 W	169 mW	1 W
C_i		11.1 nF	12.2 nF	11.1 nF
L_i		Negligible	Negligible	Negligible
Rated values		$U_N = 24 \text{ V DC}$	* $U_N = 8.2 \text{ V}$ $R_i = 1 \text{ k}\Omega$	$U_N = 24 \text{ V DC}$

TROVIS 3730-3-1300efghijklmnopqrst

e = Slot A Options: 0, 1 or 2
f = Slot B Options: 0, 1, 2 or 3
g = Slot C Options: 0, 2, 3, 4 or 5
h = Slot D Options: 0, 1, 2, 3, 4, 5 or 6
i = reserved: not safety relevant
j = reserved: not safety relevant
k = Emergency shutdown: not safety relevant
l = Electrical Connection: 0, 1 or 2
m = reserved: not safety relevant
n = Housing material: 0 or 1
o = Cover: 1 or 2
pq = Housing version: not safety relevant
r = Additional Approval: not safety relevant
s = Ship Approval: not safety relevant
t = Permissible ambient temperature: not safety relevant

13. **Specific Conditions of Use:**

None

14. **Test and Assessment Procedure and Conditions:**

This Certificate has been issued in accordance with FM Approvals US Certification Requirements.

15. **Schedule Drawings**

A copy of the technical documentation has been kept by FM Approvals.

THIS CERTIFICATE MAY ONLY BE REPRODUCED IN ITS ENTIRETY AND WITHOUT CHANGE

FM Approvals LLC, 1151 Boston-Providence Turnpike, Norwood, MA 02062 USA
T: +1 (1) 781 762 4300 F: +1 (1) 781 762 9375 E-mail: information@fmapprovals.com www.fmapprovals.com

F 347 (Apr 21)

Page 4 of 5

SCHEDULE



US Certificate Of Conformity No: FM21US0097

16. Certificate History

Details of the supplements to this certificate are described below:

Date	Description
18 th October 2022	Original Issue.
18 th January 2023	<u>Supplement 1:</u> Report Reference: RR235223 dated 18 th January 2023. Description of the Change: Typos corrected in Section 12 (Description of Equipment)

THIS CERTIFICATE MAY ONLY BE REPRODUCED IN ITS ENTIRETY AND WITHOUT CHANGE

FM Approvals LLC, 1151 Boston-Providence Turnpike, Norwood, MA 02062 USA
T: +1 (1) 781 762 4300 F: +1 (1) 781 762 9375 E-mail: information@fmaprovals.com www.fmaprovals.com

F 347 (Apr 21)

Page 5 of 5

CERTIFICATE OF CONFORMITY



- HAZARDOUS LOCATION ELECTRICAL EQUIPMENT PER CANADIAN REQUIREMENTS
- Certificate No:** FM21CA0064
- Equipment:** Type 3730-3 series TROVIS HART Positioner
(Type Reference and Name)
- Name of Listing Company:** Samson AG
- Address of Listing Company:** Weismuellerstrasse 3
Postfach 101901
Frankfurt D60314
Germany
- The examination and test results are recorded in confidential report number:
PR459607 dated 18th October 2022
- FM Approvals LLC, certifies that the equipment described has been found to comply with the following Approval standards and other documents:
CAN/CSA C22.2 No. 94-R2011, CAN/CSA-C22.2 No. 213:2017, CAN/CSA-C22.2 No. 60079-0:2019,
CAN/CSA-C22.2 No. 60079-11:2014, CAN/CSA C22.2 No. 60079-31:2015,
CAN/CSA-C22.2 No. 60529:2016, CAN/CSA-C22.2 No. 61010-1:2012
- If the sign 'X' is placed after the certificate number, it indicates that the equipment is subject to specific conditions of use specified in the schedule to this certificate.

Certificate issued by:



J/E. Marquedant
VP, Manager - Electrical Systems

18 January 2023

Date

To verify the availability of the Approved product, please refer to www.approvalguide.com

THIS CERTIFICATE MAY ONLY BE REPRODUCED IN ITS ENTIRETY AND WITHOUT CHANGE

FM Approvals LLC, 1151 Boston-Providence Turnpike, Norwood, MA 02062 USA
T: +1 (1) 781 762 4300 F: +1 (1) 781 762 9375 E-mail: information@fmapprovals.com www.fmapprovals.com

F 348 (Apr 21)



SCHEDULE



Canadian Certificate Of Conformity No: FM21CA0064

9. This certificate relates to the design, examination and testing of the products specified herein. The FM Approvals surveillance audit program has further determined that the manufacturing processes and quality control procedures in place are satisfactory to manufacture the product as examined, tested and Approved.

10. Equipment Ratings:

Intrinsically Safe for Class I, II, III Division 1, Groups A, B, C, D, E, F, and G hazardous (classified) locations in accordance with drawing EB 8484-3, Intrinsically Safe for Class I, Zone 1, Group IIC hazardous (classified) locations in accordance with drawing EB 8484-3; Nonincendive for Class I, II, III Division 2, Groups A, B, C, D, F, and G hazardous locations, indoors and outdoors (Type 4X, IP66) with an ambient temperature rating per the table in Section 11 below

11. The marking of the equipment shall include:

IS Class I, II, III, Division 1, Groups A, B, C, D, E, F, G; T* Ta*

Ex ia IIC T* Gb

NI Class I, II, III Division 2, Groups A, B, C, D, F, G; T* Ta*

Type 4X; IP66

For Entity and NIFW parameters – refer to document no. EB8484-3

T* - See below

12. Description of Equipment:

General - The Type TROVIS 3730-3 HART Positioner is a single acting positioner for attachment to pneumatic control valves. The positioner ensures a predetermined assignment of the valve position (controlled variable x) to the input signal (reference variable w). It compares the input signal received from a control system to the travel or rotational angle of the control valve and issues a corresponding output signal pressure (output variable y) for the pneumatic actuator.

Construction - The Type TROVIS 3730-3 HART Positioner mainly consists of the electronics part and one pneumatic module. The parts are assembled in an enclosure made of aluminium die cast or stainless-steel die cast. The enclosure has a cover with a polymeric inspection window. As an alternative to the polymeric material the window can be made from aluminium. The enclosure has an ingress protection rating of Type 4X and IP66

Thermal Ratings:

The correlation between temperature class and permissible ambient temperature range T_a is shown in Table 2.

Table 2:

Temperature class	Permissible ambient temperature T_a
T4	$-40\text{ °C} \leq T_a \leq +80\text{ °C}$
T6	$-40\text{ °C} \leq T_a \leq +55\text{ °C}$

THIS CERTIFICATE MAY ONLY BE REPRODUCED IN ITS ENTIRETY AND WITHOUT CHANGE

FM Approvals LLC, 1151 Boston-Providence Turnpike, Norwood, MA 02062 USA
T: +1 (1) 781 762 4300 F: +1 (1) 781 762 9375 E-mail: information@fmaprovals.com www.fmaprovals.com

F 348 (Apr 21)

Page 2 of 4

SCHEDULE



Canadian Certificate Of Conformity No: FM21CA0064

For operation with inductive limit switches used with $I_{max}/I_i = 52$ mA and $P_i = 169$ mW, the correlation between temperature class and permissible ambient temperature range is shown in Table 3.

Table 3:

Temperature class	Permissible ambient temperature T_a
T4	$-40\text{ °C} \leq T_a \leq +70\text{ °C}$
T6	$-40\text{ °C} \leq T_a \leq +45\text{ °C}$

Operation with External position sensor I

Table 3:

Temperature class	Permissible ambient temperature T_a
T4	$-30\text{ °C} \leq T_a \leq +80\text{ °C}$
T6	$-30\text{ °C} \leq T_a \leq +55\text{ °C}$

Electrical Ratings:

Circuit	Signal circuit	Position transmitter	Inductive limit switches	Software limit switches
Circuit no.	1	2	3 and 4	5 and 6
Terminal no.	+11 / -12	+31 / -32	+41 / -42 and +51 / -52	+45 / -46 and +55 / -56
V_{max} or U_i	28 V	28 V	16 V	16 V
I_{max} or I_i	115 mA	115 mA	25 mA or 52 mA	52 mA
P_i	1 W	1 W	64 mW or 169 mW	169 mW
C_i	16.3 nF	11.1 nF	71.1 nF	12.2 nF
L_i	negligible	negligible	100 μ H	negligible
Rated values	$I_N = 4$ mA...20 mA	$U_N = 24$ V DC	* $U_N = 8.2$ V $R_i = 1$ k Ω	* $U_N = 8.2$ V $R_i = 1$ k Ω
Circuit	External position sensor	Forced venting	Binary output (NAMUR)	Binary input (24 V DC)
Circuit no.	7	8	9	10
Terminal no.	V_REF / PISTE / GND	+81 / -82	+83 / -84	+87 / -88
V_{max} or U_i	4.8 V	28 V	16 V	28 V
I_{max} or I_i	64 mA	115 mA	52 mA	115 mA
P_i	74 mW	1 W	169 mW	1 W
C_i		11.1 nF	12.2 nF	11.1 nF

THIS CERTIFICATE MAY ONLY BE REPRODUCED IN ITS ENTIRETY AND WITHOUT CHANGE

FM Approvals LLC, 1151 Boston-Providence Turnpike, Norwood, MA 02062 USA
 T: +1 (1) 781 762 4300 F: +1 (1) 781 762 9375 E-mail: information@fmapprovals.com www.fmapprovals.com

SCHEDULE



Canadian Certificate Of Conformity No: FM21CA0064

L_i		Negligible	Negligible	Negligible
Rated values		$U_N = 24 \text{ V DC}$	* $U_N = 8.2 \text{ V}$ $R_i = 1 \text{ k}\Omega$	$U_N = 24 \text{ V DC}$

TROVIS 3730-3-1300efghijklmnopqrst

- e = Slot A Options: 0, 1 or 2
- f = Slot B Options: 0, 1, 2 or 3
- g = Slot C Options: 0, 2, 3, 4 or 5
- h = Slot D Options: 0, 1, 2, 3, 4, 5 or 6
- i = reserved: not safety relevant
- j = reserved: not safety relevant
- k = Emergency shutdown: not safety relevant
- l = Electrical Connection: 0, 1 or 2
- m = reserved: not safety relevant
- n = Housing material: 0 or 1
- o = Cover: 1 or 2
- pq = Housing version: not safety relevant
- r = Additional Approval: not safety relevant
- s = Ship Approval: not safety relevant
- t = Permissible ambient temperature: not safety relevant

13. **Specific Conditions of Use:**

None

14. **Test and Assessment Procedure and Conditions:**

This Certificate has been issued in accordance with FM Approvals Canadian Certification Scheme.

15. **Schedule Drawings**

A copy of the technical documentation has been kept by FM Approvals.

16. **Certificate History**

Details of the supplements to this certificate are described below:

Date	Description
18 th October 2022	Original Issue.
18 th January 2023	<u>Supplement 1:</u> Report Reference: RR235223 dated 18 th January 2023. Description of the Change: Typos corrected in Section 12 (Description of Equipment)

THIS CERTIFICATE MAY ONLY BE REPRODUCED IN ITS ENTIRETY AND WITHOUT CHANGE

FM Approvals LLC. 1151 Boston-Providence Turnpike, Norwood, MA 02062 USA
T: +1 (1) 781 762 4300 F: +1 (1) 781 762 9375 E-mail: information@fmaprovals.com www.fmaprovals.com

F 348 (Apr 21)

Page 4 of 4

Installation Manual for Apparatus certified by FM Approvals for use in Hazardous Classified Locations

Electrical rating of Intrinsically Safe / Non-Incendive Apparatus for installation in Hazardous Locations

Table 1: Maximum values

Circuit	Signal Circuit	Position Transmitter	Limit Switches Inductive	Limit Switches Software
Circuit No.	1	2	3 and 4	5 and 6
Terminal No.	+11 / -12	+31 / -32	+41 / -42 and +51 / -52	+45 / -46 and +55 / -56
V_{max} or U_i	28 V	28 V	16 V	16 V
I_{max} or I_i	115 mA	115 mA	25 mA or 52 mA	52 mA
P_i	1 W	1 W	64 mW or 169 mW	169 mW
C_i	16.3 nF	11.1 nF	71.1 nF	12.2 nF
L_i	negligible	negligible	100 µH	negligible
Rated values	I _N = 4 mA...20 mA	U _N = 24 V DC	* U _N = 8.2 V R _i = 1 kΩ	* U _N = 8.2 V R _i = 1 kΩ
Circuit	External Position Sensor	Forced Venting	Binary Output (NAMUR)	Binary Input (24 V DC)
Circuit No.	7	8	9	10
Terminal No.	V_REF / PISTE / GND	+81 / -82	+83 / -84	+87 / -88
V_{max} or U_i	4.8 V	28 V	16 V	28 V
I_{max} or I_i	64 mA	115 mA	52 mA	115 mA
P_i	74 mW	1 W	169 mW	1 W
C_i		11.1 nF	12.2 nF	11.1 nF
L_i		negligible	negligible	negligible
Rated values		U _N = 24 V DC	* U _N = 8.2 V R _i = 1 kΩ	U _N = 24 V DC

* For connection to NAMUR switching amplifier acc. to IEC 60947-5-6

Note: Entity / Nonincendive Field Wiring Parameters must meet the following requirements:

$$U_0 \text{ or } V_{oc} \leq U_i \text{ or } V_{max} / I_0 \text{ or } I_{sc} \leq I_i \text{ or } I_{max} / P_0 \leq P_i \text{ or } P_{max}$$

$$C_a \text{ or } C_0 \geq C_i + C_{cable} / L_a \text{ or } L_0 \geq L_i + L_{cable}$$

The correlation between Temperature Class and permissible ambient temperature range T_a is shown in Table 2.

Table 2:

Temperature Class	Permissible ambient temperature T _a
T4	-40 °C ≤ T _a ≤ + 80 °C
T6	-40 °C ≤ T _a ≤ + 55 °C

For operation with Inductive Limit Switches (3730-3-130.....3 or 3730-3-130.....4) used with I_{max}/I_i = 52 mA and P_i = 169 mW the correlation between Temperature Class and permissible ambient temperature range is shown in Table 3.

Table 3:

Temperature Class	Permissible ambient temperature T _a
T4	-40 °C ≤ T _a ≤ + 70 °C
T6	-40 °C ≤ T _a ≤ + 45 °C

Intrinsically Safe when installed as specified in manufacturer’s Installation Manual.

FM approved for Hazardous Locations

Class I, Division 1 and 2, Groups A, B, C, D

Class II, Division 1, Groups E, F, G

Class III, Division 1

Class I, Zone 1, AEx ia IIC T4/T6

Enclosure Type 4X / IP 66

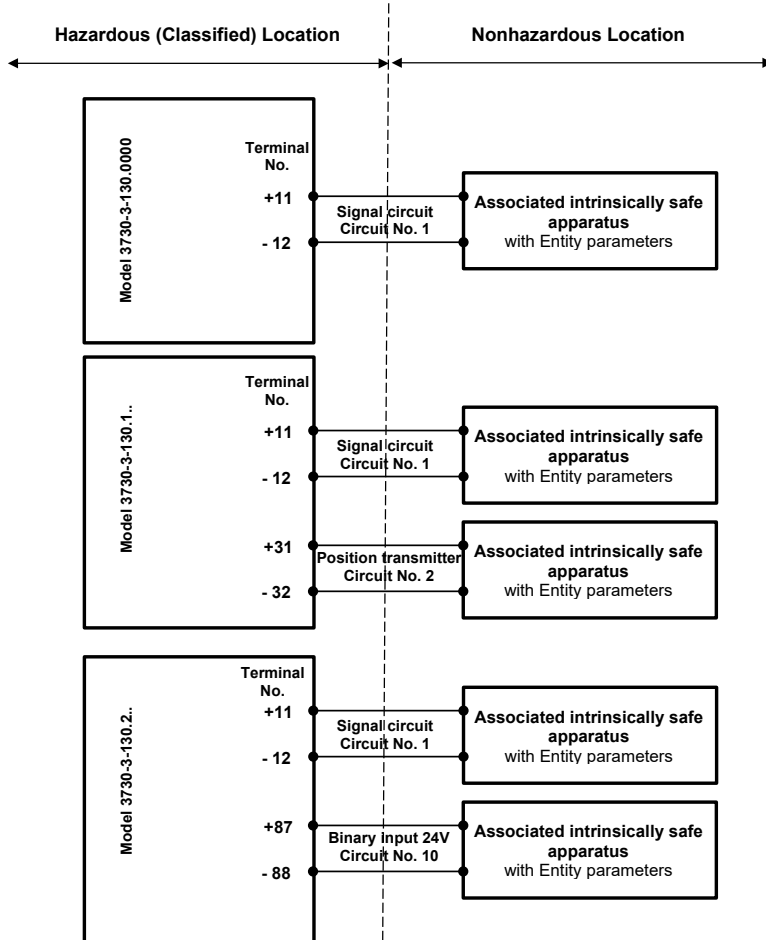

Revision Control Number: 0 / August 2022

Addendum to EB 8484-3 EN

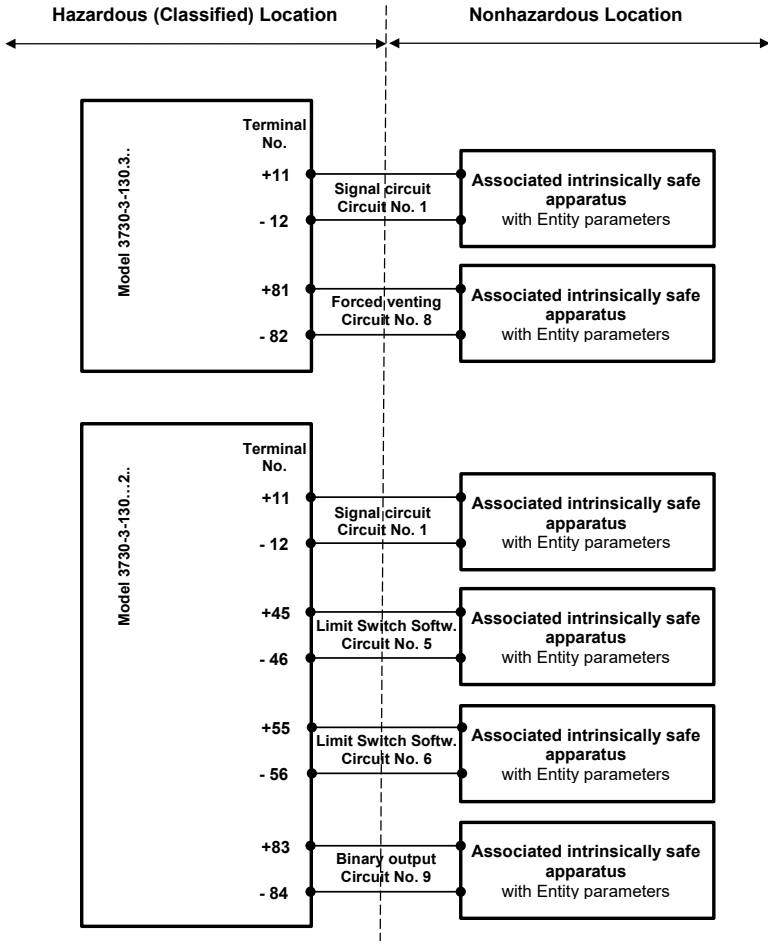

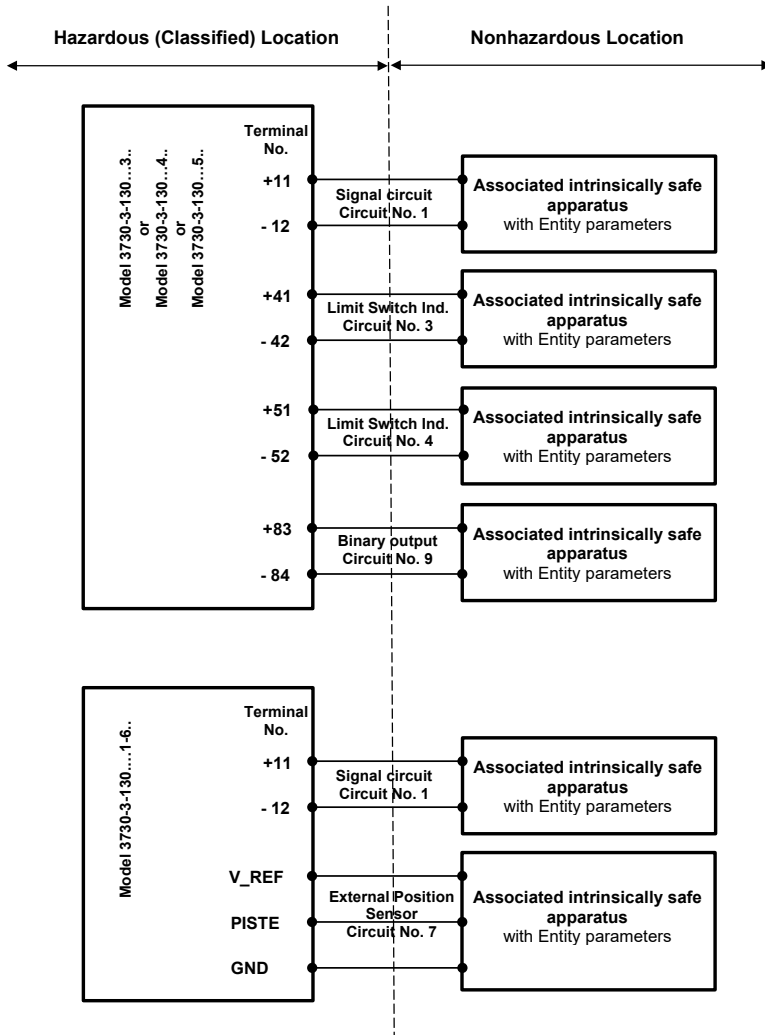

Notes:

1. The apparatus may be installed in intrinsically safe and non-incendive field wiring circuits only when used in conjunction with certified intrinsically safe or non-incendive associated apparatus. For maximum values see Table 1 on page 1.
2. For the interconnection of intrinsically safe and associated intrinsically safe apparatus not specifically examined in combination as a system, the Entity Parameters must meet following requirements:

$$\begin{array}{rcl}
 V_{OC} \text{ or } U_0 & \leq & U_i \text{ or } V_{\max} \\
 I_{SC} \text{ or } I_0 & \leq & I_i \text{ or } I_{\max} \\
 P_0 & \leq & P_i \text{ or } P_{\max} \\
 C_a \text{ or } C_O & \geq & C_i + C_{\text{Cable}} \\
 L_a \text{ or } L_O & \geq & L_i + L_{\text{Cable}}
 \end{array}$$

3. The installation must be in accordance with Canadian Electrical Code C.E.C. Part 1.
4. The installation must be in accordance with the National Electrical Code NFPA 70 and ANSI/ISA RP 12.06.01.
5. Use only supply wires suitable for 5 °C above surrounding temperature.
6. Substitution of components may impair intrinsic safety.
7. The maximum nonhazardous area voltage must not exceed 250 Vrms.
8. Cable entry M20 x 1.5 or metal conduit



IECEX Certificate of Conformity

INTERNATIONAL ELECTROTECHNICAL COMMISSION IEC Certification Scheme for Explosive Atmospheres

for rules and details of the IECEX Scheme visit www.iecex.com

Certificate No.: IECEX BVS 18.0035X Issue No: 1 Certificate history:
Issue No. 1 (2018-07-27)
Issue No. 0 (2018-06-08)

Status: Current Page 1 of 4

Date of Issue: 2018-07-27

Applicant: SAMSON AG
Weismüllerstraße 3
60314 Frankfurt am Main
Germany

Equipment: Positioner with HART® communication TROVIS 3730-3-...
Optional accessory:

Type of Protection: Equipment protection by intrinsic safety "i", Equipment protection by type of protection "n", Equipment dust ignition protection by enclosure "t"

Marking: See Annex

Approved for issue on behalf of the IECEX
Certification Body:

Ralf Leiendecker

Position:

Deputy Head of Certification Body

Signature:
(for printed version)

Date:

27.07.2018

1. This certificate and schedule may only be reproduced in full.
2. This certificate is not transferable and remains the property of the issuing body.
3. The Status and authenticity of this certificate may be verified by visiting the [Official IECEX Website](http://www.iecex.com).

Certificate issued by:

DEKRA EXAM GmbH
Dinnendahlstrasse 9
44809 Bochum
Germany

 **DEKRA**
On the safe side.



IECEx Certificate of Conformity

Certificate No: IEEx BVS 18.0035X

Issue No: 1

Date of Issue: 2018-07-27

Page 2 of 4

Manufacturer: **SAMSON AG**
Weismüllerstraße 3
60314 Frankfurt am Main
Germany

Additional Manufacturing location(s):

This certificate is issued as verification that a sample(s), representative of production, was assessed and tested and found to comply with the IEC Standard list below and that the manufacturer's quality system, relating to the Ex products covered by this certificate, was assessed and found to comply with the IECEx Quality system requirements. This certificate is granted subject to the conditions as set out in IECEx Scheme Rules, IECEx 02 and Operational Documents as amended.

STANDARDS:

The apparatus and any acceptable variations to it specified in the schedule of this certificate and the identified documents, was found to comply with the following standards:

IEC 60079-0 : 2011 Explosive atmospheres - Part 0: General requirements
Edition:6.0

IEC 60079-11 : 2011 Explosive atmospheres - Part 11: Equipment protection by intrinsic safety "I"
Edition:6.0

*This Certificate **does not** indicate compliance with electrical safety and performance requirements other than those expressly included in the Standards listed above.*

TEST & ASSESSMENT REPORTS:

A sample(s) of the equipment listed has successfully met the examination and test requirements as recorded in

Test Report:

[DE/BVS/ExTR18.0037/01](#)

Quality Assessment Report:

[DE/TUN/QAR06.0011/08](#)



IECEX Certificate of Conformity

Certificate No: IECEX BVS 18.0035X

Issue No: 1

Date of Issue: 2018-07-27

Page 3 of 4

Schedule

EQUIPMENT:

Equipment and systems covered by this certificate are as follows:

General product information:

The Positioner with HART® communication TROVIS 3730-3-... is a single acting positioner for attachment to pneumatic control valves. The positioner ensures a predetermined assignment of the valve position (controlled variable x) to the input signal (reference variable w). It compares the input signal received from a control system to the travel or rotational angle of the control valve and issues a corresponding output signal pressure (output variable y) for the pneumatic actuator.

The apparatus consists of an enclosure with several fixed mounted PCBs. In addition to the power supply terminals +11 / -12 the device contains slots for different options modules. The options modules provide additional connection terminals for external circuits. The serial interface (5 pin socket) for performing a firmware update may only be used by the manufacturer.

Depending on the type of the apparatus there are different types of protection:

TROVIS 3730-3-111... has type of protection "ia" and it may be used for applications requiring EPL Gb or Db

TROVIS 3730-3-511... has type of protection "ib" and it may be used for applications requiring EPL Db.

TROVIS 3730-3-811... has type of protection "nA" and "b" and it may be used for applications requiring EPL Gc or Db.

TROVIS 3730-3-851... has type of protection "nA" and it may be used for applications requiring EPL Gc.

The Options Module Code C includes a Pepperl+Fuchs inductive limit switch type SJ2-SN (Certificate IECEX PTB 11.0092X, standards IEC 60079-0:2011 Ed.6.0, IEC 60079-11:2011 Ed.6.0).

For TROVIS 3730-3-111... (type of protection "ia"), when using the options module Code C: Two different sets of input parameters are permissible (supply variant type 2 and type 3). If the options module is supplied with parameters type 3, the ambient temperature is limited.

Model type code:

See Annex

Ratings:

See Annex

SPECIFIC CONDITIONS OF USE: YES as shown below:

For TROVIS 3730-3-111:

For applications in Dust Group IIC, the cable glands and blanking plugs supplied must be replaced with certified ones. The cable glands and blanking plugs must be suitable for the corresponding ambient temperatures and have a degree of protection of at least IP54.



IECEx Certificate of Conformity

Certificate No: IECEx BVS 18.0035X

Issue No: 1

Date of Issue: 2018-07-27

Page 4 of 4

DETAILS OF CERTIFICATE CHANGES (for issues 1 and above):

The type denomination and model code were changed.

Annex:

[BVS_18_0035X_Samson_Annex_Issue1.pdf](#)



IECEx Certificate of Conformity



Certificate No.: IECEx BVS 18.0035X, Issue No.: 1
Annex
Page 1 of 4

Model type code:

TROVIS 3730-3-*****

a b c d e f g h i j k l m n o p q r s t

- a **Explosion protection**
- 1 1 1 Ex ia IIC T4/T6 Gb / Ex ia IIC T85°C Db
- 5 1 1 Ex tb IIC T85°C Db
- 8 1 1 Ex nA IIC T4/T6 Gc / Ex tb IIC T85°C Db
- 8 5 1 Ex nA IIC T4/T6 Gc
- b **Function**
- Not relevant
- c **Slot A Option**
- 0 Without
- 1 Position transmitter 4 to 20 mA
- 2 Binary input 24 V DC
- d **Slot B Option**
- 0 Without
- 1 Position transmitter 4 to 20 mA
- 2 Binary input 24 V DC
- 3 Forced venting
- e **Slot C Option**
- 0 Without
- 2 Software limit switches + Binary output (NAMUR)
- 3 1 x Inductive limit switches + Binary output (NAMUR)
- 4 2 x Inductive limit switches + Binary output (NAMUR)
- 5 1 x Software limit switches + 1 x Inductive limit switches + Binary output (NAMUR)
- f **Slot D Option**
- 0 Without
- 1 External travel sensor, 1050-0650 housing with M12x1 connector; with 10 m connecting cable
- 2 External travel sensor, 1050-0650 housing with M12x1 connector; ready mounted
- 3 External travel sensor; 3712 housing with connector; ready mounted
- 4 External travel sensor; 3712 housing with connector; with 10 m connecting cable
- 5 External travel sensor; 3712 housing with cable gland; ready mounted
- 6 External travel sensor; 3712 housing with 10 m connecting cable
- g **Reserved**
- Not relevant
- h **Reserved**
- Not relevant
- i **Reserved**
- Not relevant
- j **Reserved**
- Not relevant
- k **Emergency shutdown**
- Not relevant
- l **Electrical connection**
- 0 Without
- 1 Two M20x1.5, one plastic cable gland
- 2 Two M20x1.5, two metal cable glands
- m **Reserved**
- Not relevant
- n **Housing material**
- 0 Aluminium EN AC-44300DF
- 1 Stainless steel 1.4408
- o **Cover**
- 1 With round window
- 2 Closed (without window)
- p **Housing version**
- - Not relevant
- r **Additional approval**
- Not relevant
- s **Ship approval**
- Not relevant
- t **Permissible ambient temperature**
- Not relevant

- If Slot D option 5 or 6 is configured only Slot A option 0 is permitted.
- For TROVIS 3730-3-511...: For Slot D, only options 0, 5 and 6 are permitted.
- For TROVIS 3730-3-811... and TROVIS 3730-3-851...: For Slot D, only option 0 is permitted.



IECEx Certificate of Conformity



Certificate No.: IECEx BVS 18.0035X, Issue No.: 1
Annex
Page 2 of 4

Ratings:

1 Electrical Parameters for type of protection "ia"

1.1 Signal Circuit Terminal +11 / -12

Maximum input voltage	U_i	28	V
Maximum input current	I_i	115	mA
Maximum input power	P_i	1	W
Maximum internal capacitance	C_i	14.6	nF
Maximum internal inductance	L_i		negligible

1.2 Software Limit Switches (NAMUR) Terminals +45 / -46 and +55 / -56

Maximum input voltage	U_i	16	V
Maximum input current	I_i	52	mA
Maximum input power	P_i	169	mW
Maximum internal capacitance	C_i	11.1	nF
Maximum internal inductance	L_i		negligible

1.3 Binary Output (NAMUR) Terminal +83 / -84

Maximum input voltage	U_i	16	V
Maximum input current	I_i	52	mA
Maximum input power	P_i	169	mW
Maximum internal capacitance	C_i	11.1	nF
Maximum internal inductance	L_i		negligible

1.4 Binary Input (24 V DC) Terminal +87 / -88

Maximum input voltage	U_i	28	V
Maximum input current	I_i	115	mA
Maximum input power	P_i	1	W
Maximum internal capacitance	C_i	37.1	nF
Maximum internal inductance	L_i		negligible

1.5 Position Transmitter Terminal +31 / -32

Maximum input voltage	U_i	28	V
Maximum input current	I_i	115	mA
Maximum input power	P_i	1	W
Maximum internal capacitance	C_i	11.1	nF
Maximum internal inductance	L_i		negligible

1.6 Forced Venting Terminal +81 / -82

Maximum input voltage	U_i	28	V
Maximum input current	I_i	115	mA
Maximum input power	P_i	1	W
Maximum internal capacitance	C_i	11.1	nF
Maximum internal inductance	L_i		negligible

Certificate No.: IECEx BVS 18.0035X, Issue No.: 1
Annex
Page 3 of 4

1.7 Inductive Limit Switches Terminals +41 / -42 and +51 / -52

		Type 2	Type 3
Maximum input voltage	U_i	16 V	16 V
Maximum input current	I_i	25 mA	52 mA
Maximum input power	P_i	64 mW	169 mW
Maximum internal capacitance	C_i	41.1 nF	41.1 nF
Maximum internal inductance	L_i	100 μ H	100 μ H

2 Electrical Parameters for type of protection "tb" and "nA"

2.1 Signal Circuit Terminal +11 / -12

Nominal input current	I_N	4 ... 20	mA
Nominal input voltage	U_N	9.8	V
Nominal input power	P_N	212	mW

2.2 Software Limit Switches (NAMUR) Terminals +45 / -46 and +55 / -56

Nominal input voltage	U_N	8.2	V
Nominal input power	P_N	17	mW

2.3 Binary Output (NAMUR) Terminal +83 / -84

Nominal input voltage	U_N	8.2	V
Nominal input power	P_N	17	mW

2.4 Binary Input (24 V DC) Terminal +87 / -88

Nominal input voltage	U_N	24	V
Nominal input power	P_N	12	mW

2.5 Position Transmitter Terminal +31 / -32

Nominal input voltage	U_N	24	V
Nominal input power	P_N	518	mW

2.6 Forced Venting Terminal +81 / -82

Nominal input voltage	U_N	24	V
Nominal input power	P_N	173	mW

2.7 Inductive Limit Switches Terminals +41 / -42 and +51 / -52

Nominal input voltage	U_N	8.2	V
Nominal input power	P_N	17	mW



IECEx Certificate of Conformity



Certificate No.: IECEx BVS 18.0035X, Issue No.: 1
Annex
Page 4 of 4

3 Thermal Parameters

- 3.1 For TROVIS 3730-3-111... Group II application (type of protection "ia")
- | | | |
|-------------------|----|------------------------------------|
| Temperature Class | T4 | -40 °C ≤ T _{amb} ≤ +80 °C |
| Temperature Class | T6 | -40 °C ≤ T _{amb} ≤ +55 °C |
- Operation with Inductive Limit Switches supply variant type 3
- | | | |
|-------------------|----|------------------------------------|
| Temperature Class | T4 | -40 °C ≤ T _{amb} ≤ +70 °C |
| Temperature Class | T6 | -40 °C ≤ T _{amb} ≤ +45 °C |
- Operation with external position sensor
- | | | |
|-------------------|----|------------------------------------|
| Temperature Class | T4 | -30 °C ≤ T _{amb} ≤ +80 °C |
| Temperature Class | T6 | -30 °C ≤ T _{amb} ≤ +55 °C |
- 3.2 For TROVIS 3730-3-111... Group III application (type of protection "ia")
- | | | |
|-----------------------------|---------|------------------------------------|
| Maximum surface temperature | T 85 °C | -40 °C ≤ T _{amb} ≤ +55 °C |
|-----------------------------|---------|------------------------------------|
- Operation with external position sensor
- | | | |
|-----------------------------|---------|------------------------------------|
| Maximum surface temperature | T 85 °C | -30 °C ≤ T _{amb} ≤ +55 °C |
|-----------------------------|---------|------------------------------------|
- 3.3 For TROVIS 3730-3-511... and TROVIS 3730-3-811... and TROVIS 3730-3-851... (type of protection "nA" and "tb")
- | | | |
|-----------------------------|---------|------------------------------------|
| Temperature Class | T4 | -40 °C ≤ T _{amb} ≤ +80 °C |
| Temperature Class | T6 | -40 °C ≤ T _{amb} ≤ +55 °C |
| Maximum surface temperature | T 85 °C | -40 °C ≤ T _{amb} ≤ +70 °C |

Marking

Ex ia IIC T4/T6 Gb Ex ia IIIC T85°C Db	For TROVIS 3730-3-111...
Ex tb IIIC T85°C Db	For TROVIS 3730-3-511...
Ex tb IIIC T85°C Db Ex nA IIC T4/T6 Gc	For TROVIS 3730-3-811...
Ex nA IIC T6 Gc	For TROVIS 3730-3-851...

ПРИЛОЖЕНИЕ

К СЕРТИФИКАТУ СООТВЕТСТВИЯ № БАЭС RU C-DE.HA65.B.00700/20

Серия RU № 0751061

1. Описание конструкции и средств обеспечения взрывозащиты

Электропневматические позиционеры типов TROVIS 3730-1-113, TROVIS 3730-3-113 (далее по тексту – позиционеры) предназначены для установки на регулирующие пневматические клапаны для определения текущего хода или угла поворота относительно управляющего сигнала и управления клапанами. Сигнал, поступающий из системы управления, сравнивается с величиной хода/углом открытия регулирующего клапана, вырабатывая при этом управляющее давление для пневматического привода.

Позиционеры выполнены в корпусах с крышками прямоугольной формы, изготовленных из нержавеющей стали или алюминия со сплава с содержанием магния менее 7,5 %. Крышка позиционера может быть выполнена с круглым смотровым окошком и без него. Поверхность хромирована и покрыта порошковой краской. Внутри корпусов расположены электропневматический преобразователь, электронные схемы управления на платах, элементы для подключения электрических и пневматических линий. На одной боковой стороне поверхности корпуса установлены кабельные вводы, на другой – подключения пневматической системы. Кабельные вводы выполнены из полиамида, никелированной латуни или нержавеющей стали. На корпусе имеются заземляющий зажим и табличка с маркировкой.

Взрывозащищенность позиционеров обеспечивается взрывозащитой вида «искробезопасная электрическая цепь уровня «а» по ГОСТ 31610.11-2014 (IEC 60079-11:2011) и выполнением их конструкции в соответствии с требованиями ГОСТ 31610.0-2014 (IEC 60079-0:2011).

2. Специальные условия применения (если в маркировке взрывозащиты указан знак «Х»)

- 2.1. Соединение позиционеров с аппаратурой, расположенной вне взрывоопасной зоны, должно осуществляться через барьеры искрозащиты, имеющие сертификат соответствия для подключения устройств, находящихся в взрывоопасных зонах помещений и наружных установок, где возможно образование взрывоопасной газовой смеси категории IIC; входные и выходные искробезопасные параметры позиционеров с учетом параметров соединительного кабеля должны соответствовать электрическим параметрам, указанным на барьере безопасности.
- 2.2. Запрещается эксплуатация позиционеров с механическими повреждениями.
- 2.3. При эксплуатации позиционеров во взрывоопасных пылевых средах подгруппы IIIC необходимо взамен поставляемых использовать сертифицированные кабельные вводы и заглушки, учитывая условия окружающей среды. Кабельные вводы и заглушки должны иметь степень защиты от внешних воздействий не ниже IP54.
- 2.4. При установке и техническом обслуживании позиционеров необходимо принимать меры для обеспечения безопасности от статических зарядов, которые могут образоваться на поверхности смотрового окна, согласно инструкции.

3. Спецификация и идентификация продукции

Типы электропневматических позиционеров, на которые распространяется сертификат соответствия, и их маркировки взрывозащиты и защиты от воспламенения горючей пыли приведены в таблице 1.

Таблица 1

Наименование взрывозащищенного электрооборудования	Маркировка взрывозащиты	Маркировка защиты от воспламенения горючей пыли
Электропневматические позиционеры типов TROVIS 3730-1-113, TROVIS 3730-3-113	IEEx ia IIC T6... T4 Gb X	Ex ia IIIC T85 °C Db X

Подробное разъяснение к спецификационным кодам электропневматических позиционеров приводится в технической документации изготовителя.

4. Основные технические данные

- 4.1. Электропневматические позиционеры типов TROVIS 3730-1-113, TROVIS 3730-3-113

4.1.1. Степень защиты оболочки по ГОСТ 14254-2015, не ниже IP66

4.1.2. Параметры искробезопасных цепей позиционеров типа TROVIS 3730-1-113

Таблица 2

Цепь	U ₀ , В	I ₀ , мА	P ₀ , Вт	C ₀ , нФ	L ₀ , мГн
Контакты +11, -12 (цепь питания и сигнала)	28	115	1	5	пренебрежимо мала
Контакты +31, -32 (латчик фактического положения клапана)	28	115	1	5	мала
Контакты +41, -42, +51, -52 (индуктивные конечные выключатели)	16	52 (тип 3) ¹⁾ или 25 (тип 2)	0,169 (тип 3) ¹⁾ или 0,064 (тип 2)	35	100
Контакты +45, -46, +55, -56 (программируемые конечные выключатели NAMUR)	16	52	0,169	15,9	пренебрежимо мала

Руководитель (уполномоченное

лицо) органа по сертификации

Эксперт (эксперт-аудитор)

(эксперты (эксперты-аудиторы))

Пonomarev Михаил Валерьевич

М.П.

Шмелев Антон Андреевич

(Ф.И.О.)

ПРИЛОЖЕНИЕ

К СЕРТИФИКАТУ СООТВЕТСТВИЯ № ЕАЭС RU C-DE.НА65.В.00700/20

Серия **RU** № **0751062**

4.1.3. Параметры искробезопасных цепей позиционеров типа TROVIS 3730-3-113

Таблица 3

Цепь	U, В	I, мА	P, Вт	C _{нФ}	L, мкН
Контакты +11, -12 (цепь питания и сигнала)	28	115	1	14,6	пренебрежимо мала
Контакты +31, -32 (датчик фактического положения клапана)	28	115	1	11,1	
Контакты +41, -42, +51, -52 (индуктивные конечные выключатели)	16	52 (тип 3) ¹⁾ или 25 (тип 2)	0,169 (тип 3) ¹⁾ или 0,064 (тип 2)	41,1	100
Контакты +45, -46, +55, -56 (программируемые конечные выключатели NAMUR)	16	52	0,169	11,1	пренебрежимо мала
Контакты +81, -82 (магнитный клапан)	28	115	1	11,1	
Контакты +83, -84 (дискретный выход NAMUR)	16	52	0,169	11,1	
Контакты +87, -88 (дискретный вход)	28	115	1	37,1	

Примечание: ¹⁾ индуктивный конечный выключатель типа S12-SN.

4.1.4. Допустимые диапазоны температур окружающей среды (взрывоопасные газовые среды) для температурного класса, °С:

T4 минус 55...+80
T6 минус 55...+55

с индуктивными конечными выключателями типа S12-SN:

T4 минус 50...+70
T6 минус 50...+45

с внешним датчиком положения для позиционера типа TROVIS 3730-3-113:

T4 минус 30...+80
T6 минус 30...+55

4.1.5. Допустимые диапазоны температур окружающей среды (взрывоопасные пылевые среды) для температуры поверхности, °С:

T85 °С минус 55...+55

с внешним датчиком положения для позиционера типа TROVIS 3730-3-113:

T85 °С минус 30...+55

4.1.6. Габаритные размеры, масса позиционеров см. техническую документацию изготовителя

5. Техническая документация изготовителя

- 5.1. Инструкция по монтажу и эксплуатации на электропневматический позиционер TROVIS 3730-1 № EB 8484-1 RU (издание: январь 2019) от 27.03.2020
- 5.2. Инструкция по монтажу и эксплуатации на электропневматический позиционер TROVIS 3730-3 с HART® протоколом № EB 8484-3 RU (издание: март 2019) от 16.04.2020
- 5.3. Паспорта: № 4218-1000121630-001-2020.ПС от 10.02.2020, № 4218-1000121630-002-2020.ПС от 10.02.2020, № 4218-1000121630-003-2020.ПС от 10.02.2020, № 4218-1000121630-004-2020.ПС от 10.02.2020
- 5.4. Чертежи: №№ 1050-0623Т (25.06.03), 1050-0790-SWD (01.10.09), 1050-1436-SWD (16.07.15), 1050-1443-SWD (28.08.18), 1050-1444-SWD (28.08.18), 1050-1452-SWD (28.08.18), 1050-1455-SWD (30.11.17), 1050-1482-SWD (19.04.16), 1050-1519-SWD (05.11.15), 1050-1543 (28.09.17), 1050-1544 (28.09.17), 1050-1607-SWD (28.06.17), 1050-1610-SWD (28.08.18), 1050-1611-SWD (19.04.16), 1050-1617-SWD (28.08.18), 1050-1619-SWD (19.04.16), 1050-1709-SWD (28.09.17), 1050-1891-SWD (27.08.18), 1050-1688 (07.09.18), 1050-1689 (30.07.18), 1050-1731-SWD (17.07.17), 1050-1746 (23.11.17), 1050-1747 (23.11.17), 1050-1775-SWD (18.07.17), 1050-1780-SWD (28.08.17), 1050-1802-SWD (13.12.16), 1050-1936-SWD (28.08.17), 1050-2001-SWD (30.05.2018), 1050-1547 (23.05.17), 1050-1548 (29.05.17), 1050-1549 (29.05.17), 1050-1550-SWD (29.05.17), 1050-1658-SWD (18.07.17), 1050-1739 (01.08.17), 1050-1740 (01.08.17), 1050-1798-SWD (18.07.17), 1050-1894-SWD (23.08.17), 1050-1899 (06.04.2020), 1050-1911 (06.04.2020).

При внесении изготовителем или организацией, проводящей эксплуатацию оборудования, в конструкцию и (или) техническую документацию, подтверждающую соответствие оборудования и (или) Ех-компонента требованиям ТР ТС 012/2011, изменений, влияющих на показатели взрывобезопасности оборудования, изготовитель или организация, проводящая эксплуатацию оборудования, должны предоставить в орган по сертификации описание изменений, техническую документацию (чертежи средств обеспечения взрывозащиты) с внесенными изменениями и образец для проведения дополнительных испытаний, если орган по сертификации посчитает недостаточным проведение только экспертизы технической документации с внесенными изменениями для принятия решения о соответствии оборудования и (или) Ех-компонента ТР ТС 012/2011 с внесенными изменениями.

Руководитель (уполномоченное лицо) органа по сертификации

Эксперт (эксперт-аудитор) (эксперты (эксперты-аудиторы))

(подпись)
(подпись)



Пonomарев Михаил Валерьевич

Шмелев Антон Андреевич

16 Appendix A (configuration instructions)

16.1 Code list

16.1.1 Structure of the main display

Display/numbering	Description
0-0	Start screen: Valve position in %
0-1	Valve position in degrees
0-2	Set point in %
0-3	Set point deviation in %
0-4	Messages

16.1.2 Menu structure and parameters (menu level)

i Note

The availability of executed menu items and parameters depends on the positioner's configuration.

Parameters for on-site operation

Menu	Adjustment range/values [default setting]/description
Main menu	
Target operating mode 1	<p>[AUTO]: Automatic mode</p> <p>SAFE: Fail-safe position</p> <p>MAN: Manual mode</p> <p>Switchover from automatic to manual mode is bumpless.</p>
Set point (open-loop control) 2	<p>-34.0 to +34.0° [-30.0°]</p> <p>The valve can be moved manually by a positioner in open-loop control mode (positioner not yet initialized) by determining a set point. The reading in degrees is not absolute and only intended as a guide.</p>

Appendix A (configuration instructions)

Menu		Adjustment range/values [default setting]/description
Manual set point (MAN)	3	-25.0 to 125.0 % [0.0 %] Adjust the manual set point with the rotary pushbutton. The current travel/angle is displayed in % when the positioner is initialized. If the positioner is not initialized, the position of the lever in relation to the longitudinal axis is indicated in degrees (°).
Reason for fail-safe position	4	Reason for change to fail-safe position displayed. The parameter is only displayed in the event of a change to the fail-safe position.
Change reading direction	5	Reading direction / direction direction / Reading direction The reading direction of the display is turned by 180°.
User level	6	[On-site (read only)]/On-site The option to change data is unlocked (revoked if no settings are entered within five minutes).
Start-up	7	
Actuator	7.1	[Linear actuator] Rotary actuator Linear actuator (expert) Select type of actuator: linear actuator (expert) with separate setting options for pin position and nominal range.
Pin position		Follower pin must be mounted in the proper position depending on the valve travel/opening angle (see travel tables in the 'Installation' chapter).
Pin position for linear actuator	7.2	[None]/17/25/35/50/70/100/200/300 mm
Pin position for rotary actuator	7.3	90°
Pin position for linear actuator (expert)	7.4	[10] to 655 mm The pin position is continuously adjustable within the specified range.
Nominal range		The possible adjustment range depends on the selected pin position. If no pin position has been entered, 'Nominal range' is only available for the 'Linear actuator (expert)' actuator type (see travel tables in the 'Installation' chapter).
Nominal range for linear actuator	7.5	60.0 to 300.0 [200.0]

Menu		Adjustment range/values [default setting]/description
Nominal range for rotary actuator	7.6	24.0 to 100.0° [90.0°]
Nominal range for linear actuator (expert)	7.7	[3.6] to 655.0 mm
Max. nom. range	7.8	Maximum possible nominal range displayed, depending on values entered for pin position and nominal range.
Detected nominal range	7.9	Determined nominal range for rotary actuators displayed.
Initialization mode	7.10	[MAX]: Travel/angle of the closure member from the CLOSED position to the opposite stop in the actuator. NOM: Travel/angle of the closure member measured from the CLOSED position to the indicated OPEN position. MAN: Manually selected range SUB: Substitute calibration (without initialization)
Volume booster	7.11	If the positioner is combined with a volume booster, this parameter must be set accordingly. [Not available]/Available
Reversing amplifier	7.12	If a reversing amplifier is connected to the positioner, this parameter must be set accordingly. [Not available]/Available
Fail-safe position	7.13	Reading of the ATO/ATC slider switch position
Set point (open-loop control)	7.14	-90.0 to 90.0° [-30.0°]
Adopt valve position 1	7.15	Manually adjusted first end position of the valve in MAN initialization mode Confirm to adopt.
Valve position 1	7.16	Reading only (lever position in degrees)
Adopt valve position 2	7.17	Manually adjusted second end position of the valve in MAN initialization mode Confirm to adopt.
Valve position 2	7.18	Reading only (lever position in degrees)
Current valve position	7.19	-25.0 to 125.0 % [0.0 %]

Appendix A (configuration instructions)

Menu		Adjustment range/values [default setting]/description
Direction of rotation	7.20	Counterclockwise/[Clockwise] Determine the lever's direction of rotation. For example: The valve closes when the plug stem moves downward. This action causes the positioner's lever to turn counterclockwise (when looking at the display). →Setting: Counterclockwise
Start initialization	7.21	Confirm to start.
Start zero calibration	7.22	Confirm to start.
Valid initialization	7.27	The Valid initialization folder lists parameter values used for the last initialization of the positioner. In the event of a failed initialization, the values of the last successful initialization remain saved in this folder even if the parameters have changed in the mean time. These parameter values are only overwritten when a further initialization has been successfully completed. All listed parameters are set to their default setting on the first start-up of the positioner.
Initialization mode	7.27.1	Reading of initialization mode entered in 7.10.
Actuator	7.27.2	Reading of actuator type entered in 7.1.
Pin position	7.27.3	Reading of pin position entered in 7.2.
Pin position	7.27.4	Reading of pin position entered in 7.3.
Pin position	7.27.5	Reading of pin position entered in 7.4.
Nominal range	7.27.6	Reading of nominal range entered in 7.5/7.7.
Nominal range	7.27.7	Reading of nominal range entered in 7.6.
Volume booster	7.27.8	Reading of volume booster entered in 7.11.
Reversing amplifier	7.27.9	Reading of reversing amplifier entered in 7.11.2.
Fail-safe position	7.27.10	Reading of the ATO/ATC slider switch position
T98 (supply)	7.27.11	Time [ms] required to fill the actuator with air to achieve a step from 0 to 98 %. The value is determined during initialization.
T98 (exhaust)	7.27.12	Time [ms] required to vent the actuator to achieve a step from 0 to 98 %. The value is determined during initialization.
Loop gain (supply)	7.27.13	Reading of loop gain (supply) entered in 8.4.4.
Loop gain (exhaust)	7.27.14	Reading of loop gain (exhaust) entered in 8.4.8.

Menu		Adjustment range/values [default setting]/description
Configuration	8	
Set point processing	8.1	
Lower w-range value	8.1.1	<p>[0.0] to 75.0 %</p> <p>The lower set point range value must be lower than upper range value (w-end), 0 % = 4 mA.</p> <p>The set point range is the difference between w-end and w-start and must be $\Delta w \geq 25 \% = 4 \text{ mA}$.</p> <p>When the set point range of 0 to 100 % = 4 to 20 mA, the valve must move through its entire operating range from 0 to 100 % travel/angle of rotation.</p> <p>In split-range operation, the valves operate with smaller set points. The control signal of the control unit to control two valves is divided such, for instance, that the valves move through their full travel/angle of rotation at only half the input signal (first valve set to 0 to 50 % = 4 to 12 mA and second valve set to 50 to 100 % = 12 to 20 mA).</p>
Upper w-range value	8.1.2	<p>25.0 to [100.0 %]</p> <p>The upper range value of the set point range must be greater than lower range value (w-start).</p>
Direction of action	8.1.3	<p>[Increasing/increasing] or Increasing/decreasing</p> <p>The set point's effect on the valve position is determined as follows:</p> <ul style="list-style-type: none"> – Increasing/increasing: a globe valve opens as the set point increases. – Increasing/decreasing: a globe valve closes as the set point increases.
Characteristic	8.1.4	<p>Select one of the following characteristics:</p> <p>[Linear]</p> <p>Equal percentage</p> <p>Reverse equal percentage</p> <p>Butterfly valve, linear</p> <p>Butterfly valve, equal percentage</p> <p>Rotary plug valve, linear</p> <p>Rotary plug valve, equal percentage</p> <p>Segmented ball valve, linear</p> <p>Segmented ball valve, equal percentage</p> <p>User-defined (setting in TROVIS-VIEW)</p>

Appendix A (configuration instructions)

Menu		Adjustment range/values [default setting]/description
Lower x-range value	8.1.5	<p>[0.0] to 99.0 % Lower range value for travel/angle in nominal or operating range The operating range is the actual travel/angle of the valve and is limited by the lower travel/angle range value and the upper travel/angle range value. Usually, the operating range and the nominal range are identical. The nominal range can be limited to the operating range by the lower and upper x-range values. The value is displayed or must be entered. The characteristic is adapted. The difference between the lower and upper x-range values must be at least 1 %.</p>
Upper x-range value	8.1.6	<p>1.0 to [100.0 %] Upper range value for travel/angle in nominal or operating range The value is displayed or must be entered. The characteristic is adapted. Example: The operating range is modified, for example to limit the range of a control valve which has been sized too large. For this function, the entire resolution range of the set point is converted to the new limits. 0 % on the display corresponds to the adjusted lower limit and 100 % to the adjusted upper limit. The difference between the lower and upper x-range values must be at least 1 %.</p>
Ramp time (rising)	8.1.7	<p>[0.0] to 10000.0 s Time required to move through the operating range when the valve opens. For some applications it is recommendable to limit the transit time of the actuator to prevent it from engaging too fast in the running process.</p>
Ramp time (falling)	8.1.8	<p>[0.0] to 10000.0 s Time required to move through the operating range when the valve closes.</p>
Lower end position	8.1.9	[Activated]/Deactivated
End position $w \leq$ (set point cutoff decrease)	8.1.10	<p>0.0 to 49.0 % [1.0 %] If the set point w reaches up to the entered percentage at the final value that causes the valve to close, the actuator is immediately completely vented (with AIR TO OPEN) or filled with air (with AIR TO CLOSE). This action always lead to maximum tight-closing of the valve.</p>

Menu		Adjustment range/values [default setting]/description
Upper end position	8.1.11	[Deactivated]/Activated
End position w >= (set point cutoff increase)	8.1.12	51.0 to 100.0 % [99.0 %] If the set point w reaches up to the entered percentage at the final value that causes the valve to open, the actuator is immediately filled with air (with AIR TO OPEN) or completely vented (with AIR TO CLOSE). This action always lead to the valve being completely opened. Example: set the cutoff to 99 % for three-way valves.
Identification	8.2	
Positioner	8.2.1	
Firmware version	8.2.1.1	Indicates firmware version.
Hardware version	8.2.1.2	Indicates the hardware version.
Serial number	8.2.1.3	Indicates serial number.
HART® communication	8.3	
Non-conducting	8.3.1	Yes/[No]
Fixed value (communication)	8.3.2	Active/[Not active]
Fixed value (communication)	8.3.3	1.0 to [100.0 %]
Polling address	8.3.4	[0] to 63
Loop current value	8.3.5	0/1
Tag no.	8.3.6	Entry of max. 8 characters
Description	8.3.7	Entry of max. 16 characters
Tag no. (long)	8.3.8	Entry of max. 32 characters
Preambles	8.3.9	[5] to 20
Find device flag	8.3.10	Yes/[No]
Final assembly number	8.3.11	Read only
Control parameters	8.4	

Appendix A (configuration instructions)

Menu		Adjustment range/values [default setting]/description
 Tip The control parameters are explained in the SAMSON brochure ► <i>Controllers and Controlled Systems as part of the Technical Information series (www.samsongroup.com > Service & Support > Downloads > Documentation).</i>		
Dead band	8.4.1	[0.1] to 100.0 %
Activate integral-action component	8.4.2	[Active]/Not active
User-defined control parameters	8.4.3	[Not active]/Active
Loop gain (supply)	8.4.4	1 to 650 [10]
Kp (supply)	8.4.5	0.1 to 200 [27]
Ki (supply)	8.4.6	0.1 to 100 [7.5]
Kd (supply)	8.4.6	0.5 to 200 [100]
Loop gain (exhaust)	8.4.8	1 to 650 [50]
Kp (exhaust)	8.4.9	0.1 to 200 [18]
Ki (supply)	8.4.10	0.1 to 100 [7.5]
Kd (exhaust)	8.4.11	0.5 to 200 [100]
End position (optimized)	8.4.12	[Active]/Not active
Options	8.5	
Module status	8.5.1	Read only
Identification	8.5.2	Read only
Option A	8.5.3	Parameters for option A (see parameter description on page 16-10 onwards)
Module status	8.5.4	Read only
Identification	8.5.5	Read only
Option B	8.5.6	Parameters for option B (see parameter description on page 16-10 onwards)
Module status	8.5.7	Read only
Identification	8.5.8	Read only
Limit switch 1	8.5.9...	
Limit contact 2	8.5.10...	

Menu		Adjustment range/values [default setting]/description
Limit contact 3	8.5.11...	
Terminal designation1	Read only
Function3	Read only
Mode4	Below limit Above limit
Edge control5	Conducting/high Locking/low
Limit6	-20.0 to 120.0 %
Current state7	Read only
Start DO test.8	Confirm to start.
Test mode9	Read only
External position sensor status	8.5.12	Read only
External position sensor	8.5.13	
Type	8.5.13.1	Read only
Terminal designation	8.5.13.2	Read only
Function	8.5.13.3	Read only
External position sensor ID	8.5.13.4	Read only
External position sensor signal (raw)	8.5.13.5	Read only
External position sensor signal	8.5.13.6	Read only
Selecting the position sensor	8.5.13.8	Read only

Appendix A (configuration instructions)

Parameters of options

i Note

The availability of parameters depends on the options used.

Menu		Adjustment range/values [default setting]/description
Configuration	8	
Options	8.5	
Option A	8.5.3	
Terminal designation	8.5.3.1	Read only
Function	8.5.3.3	Binary input (24 V)
Configuration	8.5.3.4	Contact (switch) Contact (0 to 24 V)
Action upon active binary input	8.5.3.5	Switching state Activate local write protection Start PST Start FST Move valve to fixed value
Fixed value over binary input	8.5.3.6	0.0 to 100.0 %
Edge control	8.5.3.7	Active = Switch closed Active = Switch open
Function	8.5.3.8	Reading Software limit switch Fault alarm output
Mode	8.5.3.9	Below limit Above limit
Edge control	8.5.3.10	Conducting/high Locking/low
Function	8.5.3.11	Leakage sensor
Function	8.5.3.12	Position transmitters
Position transmitter's direction of action	8.5.3.13	Increasing/increasing Increasing/decreasing
Error message at position transmitter	8.5.3.14	None low high

Menu		Adjustment range/values [default setting]/description
Limit	8.5.3.15	-20.0 to 120.0 %
Current state	8.5.3.16	Read only
Signal of analog output	8.5.3.17	Read only
Current state	8.5.3.18	Read only
Signal of analog output	8.5.3.19	Read only
Start DO test.	8.5.3.20	Confirm to start.
Start AO test.	8.5.3.21	Confirm to start.
Test mode	8.5.3.22	Read only
Test signal of analog output	8.5.3.23	-10.0 to 110.0 %
Option B		
Function	8.5.6.3	Binary input (24 V)
Configuration	8.5.6.4	Contact (switch) Contact (0 to 24 V)
Action upon active binary input	8.5.6.5	Switching state Activate local write protection Start PST Start FST Move valve to fixed value
Fixed value over binary input	8.5.6.6	0.0 to 100.0 %
Edge control	8.5.6.7	Active = Switch closed Active = Switch open
Function	8.5.6.8	Reading Software limit switch Fault alarm output
Mode	8.5.6.9	Below limit Above limit
Edge control	8.5.6.10	Conducting/high Locking/low
Function	8.5.6.11	Leakage sensor
Function	8.5.6.12	Position transmitters
Position transmitter's direction of action	8.5.6.13	Increasing/increasing Increasing/decreasing

Appendix A (configuration instructions)

Menu		Adjustment range/values [default setting]/description
Error message at position transmitter	8.5.6.14	None low high
Error message in case of condensed state	8.5.6.15	Yes/No
Limit	8.5.6.16	-20.0 to 120.0 %
Current state	8.5.6.17	Read only
Signal of analog output	8.5.6.18	Read only
Current state	8.5.6.19	Read only
Signal of analog output	8.5.6.20	Read only
Start DO test.	8.5.6.21	Confirm to start.
Start AO test.	8.5.6.22	Confirm to start.
Test mode	8.5.6.23	Read only
Test signal of analog output	8.5.6.24	-10.0 to 110.0 %

Readable process data

Menu		Adjustment range/values [default setting]/description
Process data	9	
Current operating mode	9.1	Indicates current operating mode
Reason for fail-safe position	9.2	Reason for fail-safe position displayed
Set point	9.3	Reading in %
Manual set point (MAN)	9.4	Reading of adjusted set point
Set point after filter	9.5	Reading of adjusted set point after set point processing (split range, tight-closing function etc.)
Valve position	9.6	Reading in degrees
Valve position	9.7	Reading in %
Set point deviation	9.8	Reading in %
Temperature inside device	9.9	Reading in °C
Fixed value (communication)	9.10	Reading in %

Menu		Adjustment range/values [default setting]/description
Fixed value (communication)	9.11	Active/Not active
Fixed value over binary input	9.12	Reading in %
Fixed value over binary input	9.13	Active/Not active
Diagnosis/maintenance	10	
Device state	10.1	
Status messages	10.1.1	
Condensed state	10.1.1.1	
Start-up	10.1.1.2	Messages which may be displayed: see parameter descriptions on page 16-14 onwards
Configuration	10.1.1.29	
Process data	10.1.1.35	
Diagnostics	10.1.1.40	
Total valve travel	10.1.2	Totaled full valve travel cycle
Total valve travel limit x 1000	10.1.3	Limit of total valve travel limit
Lag time for set point deviation	10.1.4	Reading in s. The lag time can only be set using the operator software.
Tolerance band for set point deviation +/-	10.1.5	Used for error monitoring.
Max. temperature inside device ¹⁾	10.1.6	Reading in °C
Min. temperature inside device ¹⁾	10.1.7	Reading in °C
Operating hours counter	10.1.8	Reading in d:hh:mm:ss
Number of initializations	10.1.9	Number of initializations performed
Number of zero calibrations	10.1.10	Reading indicates the number of zero calibrations performed since the last initialization.

Appendix A (configuration instructions)

Menu		Adjustment range/values [default setting]/description
Tests	10.2	
Step response test (PST)	10.2.1	Test to check the valve's ability to move and assess its dynamic control response (PST: partial stroke test/FST: full stroke test).
Start PST	10.2.1.1	Start test
Test status	10.2.1.3	Reading as progress bar
Canceled: x monitoring	10.2.1.4	Reading in %. Canceled when range is violated.
Step response test (FST)	10.2.2	
Start FST	10.2.2.1	Start test
Test status	10.2.2.3	Reading as progress bar

Diagnosis: status messages

Menu		Adjustment range/values [default setting]/description
Diagnosis/ maintenance	10	
Device state	10.1	
Status messages	10.1.1	
Condensed state	10.1.1.1	Status indicators
Start-up	10.1.1.2	Status indicators
Initialization error	10.1.1.3	Status indicators
Incorrect operating mode	10.1.1.4	The incorrect operating mode is set.
	Recommended action:	Change operating mode.
	10.1.1.5	Confirm to clear message.
Travel too small	10.1.1.6	The determined travel is below the limit.
	Recommended action:	Check positioner attachment, pin position and supply pressure.
	10.1.1.7	Confirm to clear message.

¹⁾ The displayed value is merely intended as information. No error message is displayed with the ambient temperature exceeds or falls below the permissible range (see Technical data in the 'Design and principle of operation' chapter).

Menu		Adjustment range/values [default setting]/description
Rated travel not achieved	10.1.1.8	The detected rated travel is smaller than the value in the setting.
	Recommended action:	Check positioner attachment, pin position and supply pressure.
	10.1.1.9	Confirm to clear message.
No movement	10.1.1.10	Possible cause: valve blockage.
	Recommended action:	Check positioner mounting, pin position and supply air. Check piping and configuration of the mounting parts. Move the positioner out of the fail-safe position.
	10.1.1.11	Confirm to clear message.
Pin position	10.1.1.12	The adjusted lever M does not match the rated travel.
	Recommended action:	Check pin position.
	10.1.1.13	Confirm to clear message.
Canceled (control accuracy)	10.1.1.14	Control criteria are not fulfilled.
	Recommended action:	Check positioner attachment, pin position and supply air. Re-initialize the positioner. Possibly use a screw restriction.
	10.1.1.15	Confirm to clear message.
Low control accuracy	10.1.1.16	Control criteria are not fulfilled.
	Recommended action:	Check positioner attachment, pin position and supply air. Re-initialize the positioner. Possibly use a screw restriction.
	10.1.1.17	Confirm to clear message.
Positioner not initialized	10.1.1.18	The positioner needs to be initialized.
	Recommended action:	Perform an initialization.
Initialization canceled (external)	10.1.1.19	Initialization was canceled, e.g. due to forced venting or IP shutdown.
	Recommended action:	Check power supply/electrical signal. Re-initialize the positioner.
	10.1.1.20	Confirm to clear message.

Appendix A (configuration instructions)

Menu		Adjustment range/values [default setting]/description
Angle limitation	10.1.1.21	The maximum permissible angle of rotation ($\pm 30^\circ$) has been exceeded.
	Recommended action:	Check positioner attachment, lever and pin position.
	10.1.1.22	Confirm to clear message.
Timeout	10.1.1.23	Initialization took too long. Possible cause: valve blockage.
	Recommended action:	Check positioner mounting, pin position and supply air. Check piping and configuration of the mounting parts.
	10.1.1.24	Confirm to clear message.
Zero calibration error	10.1.1.25	The zero calibration could not be completed. The forced venting may possibly be active.
	Recommended action:	Check positioner attachment, pin position and supply air. Check the set operating mode. Search for the reason why the forced venting was triggered.
Zero calibration timeout	10.1.1.26	Zero calibration took too long.
	Recommended action:	Check positioner attachment, pin position and supply air.
	10.1.1.27	Confirm to clear message.
Zero calibration: shift >>	10.1.1.28	The difference to the previous zero point is too large.
	Recommended action:	Check positioner attachment, pin position and supply air.
Configuration	10.1.1.29	Status indicators
Combination of options invalid	10.1.1.30	Impermissible combination of options
	Recommended action:	Contact our after-sales service.
Forced venting switch incorrect	10.1.1.31	Impermissible mounting situation for forced venting option
	Recommended action:	Contact our after-sales service.
Binary input option A active	10.1.1.32	Reading matches the configuration of optional additional function.
Binary input option B active	10.1.1.33	Reading matches the configuration of optional additional function.
External position sensor error	10.1.1.34	The sensor or sensor lead are defective.
	Recommended action:	Check sensor and sensor lead.

Menu		Adjustment range/values [default setting]/description
Process data	10.1.1.35	Status indicators
Operating mode not AUTO	10.1.1.36	The positioner is in an operating mode other than AUTO. An error does not exist.
Forced venting function	10.1.1.37	The forced venting is active.
	Recommended action:	Check supply voltage. Search for the reason why the forced venting was triggered.
Test in progress	10.1.1.38	The positioner is in the test mode (e.g. initialization process, step response test etc.). Test mode can be canceled.
Emergency mode active	10.1.1.39	Emergency mode is active. Possible cause: travel measurement does not function properly.
	Recommended action:	Check travel measurement.
Control valve diagnosis	10.1.1.40	Status indicators
PST	10.1.1.41	Status indicators
PST: cancellation criteria met	10.1.1.42	PST is canceled.
	Recommended action:	Positioner configuration. Check valve and positioner attachment.
PST: start criteria not met	10.1.1.43	PST did not start.
	Recommended action:	Check the positioner configuration.
FST	10.1.1.44	Status indicators
FST: cancellation criteria met	10.1.1.45	FST is canceled.
	Recommended action:	Positioner configuration. Check valve and positioner attachment.
FST: start criteria not met	10.1.1.46	FST did not start.
	Recommended action:	Check the positioner configuration.
AMR signal outside range	10.1.1.47	Travel measurement is defective. Possible cause: an external malfunction or a hardware error may possibly exist.
	Recommended action:	Check positioner attachment, pin position and supply air. Check power supply/electrical signal.
	10.1.1.48	Confirm to clear message.

Appendix A (configuration instructions)

Menu		Adjustment range/values [default setting]/description
Hardware fault	10.1.1.49	Internal device error. Initialization key (INIT) jammed.
	Recommended action:	Restart the positioner. Contact our after-sales service.
Limit for total valve travel exceeded	10.1.1.50	Limit of total valve travel limit exceeded.
	Recommended action:	Check the control valve to ensure it functions properly.
Lower end position shifted	10.1.1.51	Possible cause: mounting arrangement or travel linkage of positioner has slipped.
	Recommended action:	Check the plug, seat and control valve to ensure they function properly.
	10.1.1.52	Confirm to clear message.
Upper end position shifted	10.1.1.53	Possible cause: mounting arrangement or travel linkage of positioner has slipped.
	Recommended action:	Check the plug, seat and control valve to ensure they function properly.
	10.1.1.54	Confirm to clear message.
Dynamic stress factor exceeded	10.1.1.55	The limit is exceeded. It may be necessary to change the valve packing.
	Recommended action:	Order spare part, if necessary.
Set point deviation	10.1.1.56	Control loop error, the valve no longer follows the controlled variable within tolerable times.
	Recommended action:	Check positioner attachment and supply pressure.
Brownout	10.1.1.57	Brief power failure. The positioner remains ready for use.
	Recommended action:	Check power supply/electrical signal.
	10.1.1.58	Confirm to clear message.
Current too low	10.1.1.59	Set point <3.7 mA
	Recommended action:	Check power supply/electrical signal.
IP shutdown	10.1.1.60	Set point <3.85 mA
	Recommended action:	Check power supply/electrical signal.
Current too high	10.1.1.61	Set point >22 mA. The positioner remains ready for use.
	Recommended action:	Check power supply/electrical signal.

Menu		Adjustment range/values [default setting]/description
Temperature inside device below min. limit	10.1.1.62	Warning not affecting the positioner's functioning.
	Recommended action:	Check the ambient temperature.
Temperature inside device above max. limit	10.1.1.63	Warning not affecting the positioner's functioning.
	Recommended action:	Check the ambient temperature.
Angle limitation	10.1.1.64	The maximum permissible angle of rotation ($\pm 30^\circ$) has been exceeded (only in open-loop control mode).
	Recommended action:	Check positioner attachment, pin position and supply air.
Logging suspended	10.1.1.65	Confirm to clear message.
	10.1.1.66	It was not possible to write all logging entries (possibly the volume data was briefly too high).
Logging suspended	Recommended action:	Restart the positioner.
	10.1.1.67	Confirm to clear message.
Operating range in CLOSED position	10.1.1.68	The operating range may have shifted and is close to the end position.
	Recommended action:	Check the attachment as well as the control valve to ensure it functions properly.
Operating range in max. OPEN position	10.1.1.69	The operating range may have shifted and is close to the end position.
	Recommended action:	Check the attachment as well as the control valve to ensure it functions properly.
Limited working range: lower range	10.1.1.72	There may be leakage or a blockage.
	Recommended action:	Check the attachment as well as the control valve to ensure it functions properly.
Limited working range: upper range	10.1.1.73	There may be leakage or a blockage.
	Recommended action:	Check the attachment as well as the control valve to ensure it functions properly.

Appendix A (configuration instructions)

Reset functions

Menu		Adjustment range/values [default setting]/description
Reset functions	11	
Reset diagnosis	11.1	Resets all diagnostic functions including graphs and histograms.
Reset (standard)	11.2	Resets the positioner to the state as upon delivery. Actuator and valve-specific settings remain unchanged.
Reset (advanced)	11.3	All parameters will be reset to their defaults adjusted upon delivery.
Restart	11.4	The positioner is shut down and restarted.
Reset initialization	11.5	All parameters for the start-up settings are reset. The positioner needs to be re-initialized afterwards.

Menu		Adjustment range/values [default setting]/description
Wizard	12	
Reading direction	12.1	[Right pneumatic connection]/Left pneumatic connection Mounting position with pneumatic modules on the right or left-hand side of the display
Sprache/Language	12.2	[English]/Deutsch/Français Menu language
Settings completed	12.3	Exit wizard

16.2 Valve characteristic selection

The characteristics that can be selected in menu item **8.1.9** are shown in the following in graph form.

i Note

A characteristic can only be defined (user-defined characteristic) using an operating software (e.g. SAMSON's TROVIS-VIEW or DD/DTM/EDD).

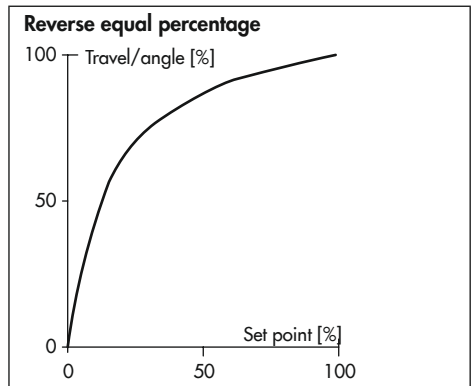
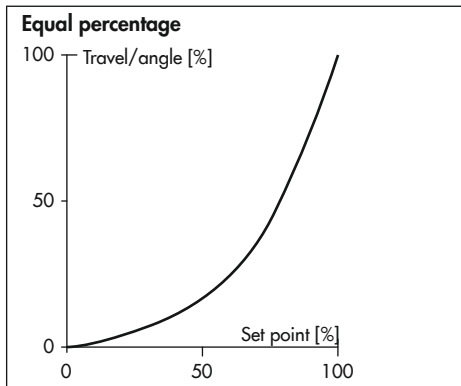
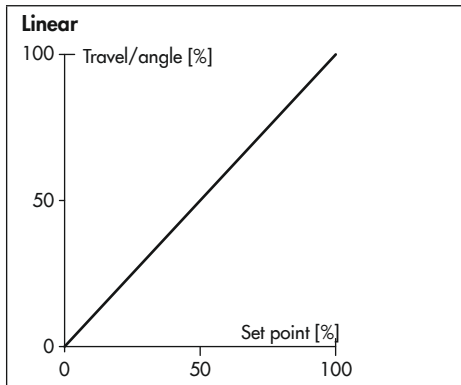

Appendix A (configuration instructions)

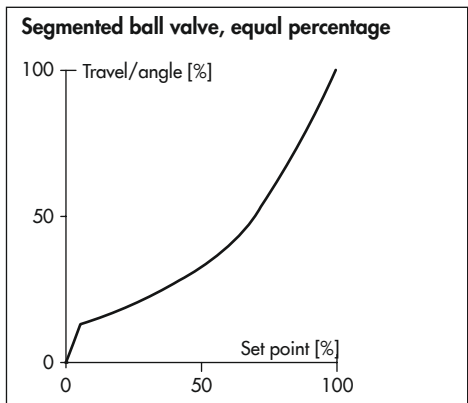
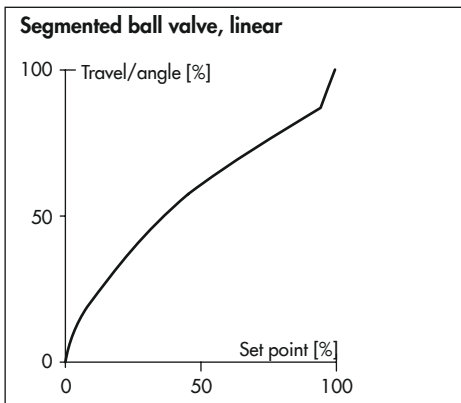
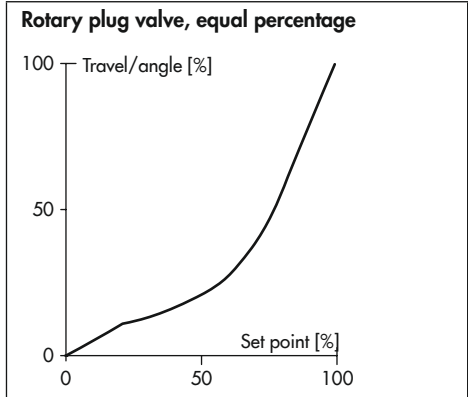
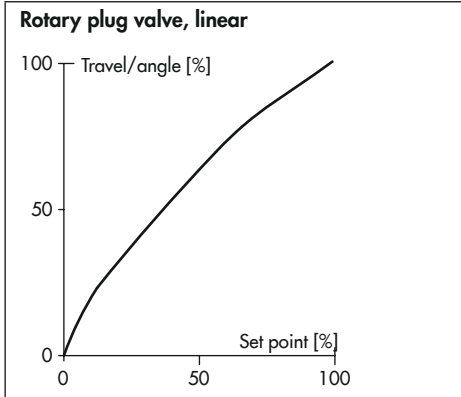
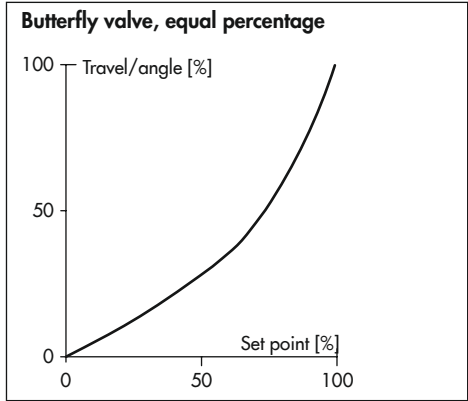
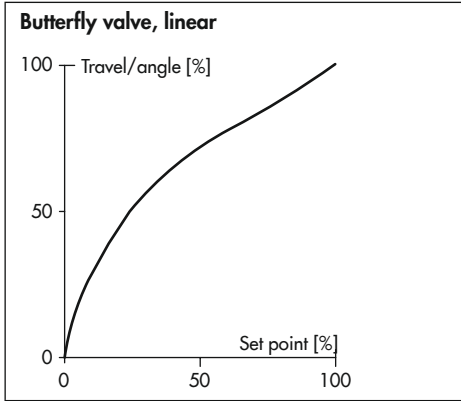

17 Appendix B

17.1 After-sales service

Contact our after-sales service for support concerning service or repair work or when malfunctions or defects arise.

You can reach our after-sales service at aftersalesservice@samsongroup.com.

Addresses of SAMSON AG and its subsidiaries

The addresses of SAMSON AG, its subsidiaries, representatives and service facilities worldwide can be found on our website (www.samsongroup.com) or in all SAMSON product catalogs.

Required specifications

Please submit the following details:

- Order number and position number in the order
- Model number, configuration ID, serial number, firmware version (see the 'Markings on the device' chapter for nameplate details)



SAMSON AKTIENGESELLSCHAFT
Weismüllerstraße 3 · 60314 Frankfurt am Main, Germany
Phone: +49 69 4009-0 · Fax: +49 69 4009-1507
samson@samsongroup.com · www.samsongroup.com