

Series 3731
Type 3731-3 Electropneumatic Ex d
Positioner



with HART® communication



Fig. 1 · Type 3731-3



Mounting and Operating Instructions

EB 8387-3 EN

Firmware version 1.53

Edition May 2017



Definitions of the signal words used in these instructions

 **DANGER!**

indicates a hazardous situation which, if not avoided, will result in death or serious injury.

WARNING!

indicates a hazardous situation which, if not avoided, could result in death or serious injury.

NOTICE

indicates a property damage message.

Note: *Supplementary explanations, information and tips*

Contents

1	Important safety instructions	6
2	Article code	7
3	Design and principle of operation	8
3.1	Additional equipment	9
3.2	Communication	10
3.2.1	Configuration using TROVIS-VIEW software	10
3.3	Technical data	12
4	Attachment to the control valve – Mounting parts and accessories	15
4.1	Direct attachment	17
4.1.1	Type 3277-5 Actuator	17
4.1.2	Type 3277 Actuator	20
4.2	Attachment according to IEC 60534-6 (NAMUR)	22
4.3	Attachment to Type 3510 Micro-flow Valve	24
4.4	Attachment to rotary actuators	26
4.5	Reversing amplifier for double-acting actuators	28
4.5.1	Reversing amplifier (1079-1118 or 1079-1119)	28
4.6	Required mounting parts and accessories	30
5	Connections	34
5.1	Pneumatic connections	34
5.1.1	Signal pressure gauges	35
5.1.2	Supply pressure	35
5.1.3	Signal pressure (output)	35
5.2	Electrical connections	36
5.2.1	Establishing communication	40
6	Operator controls and readings	42
6.1	Rotary pushbutton	42
6.2	Serial interface	42
6.3	Readings on display	42
6.4	HART® communication	45
6.4.1	Dynamic HART® variables	45
7	Start-up – Settings	46
7.1	Adapting the display	47
7.2	Limiting the signal pressure	47
7.3	Checking the operating range of the positioner	48
7.4	Allocating the closed position	49
7.5	Positioner initialization	49

7.5.1	Initialization based on MAX maximum range	51
7.5.2	Initialization based on NOM nominal range	52
7.5.3	Initialization based on MAN manually selected range	53
7.5.4	SUB substitute calibration	55
7.6	Zero calibration	58
7.7	Reset to default values	59
8	Operation	60
8.1	Enabling and selecting parameters	60
8.2	Operating modes	61
8.2.1	Automatic (AUTO) and manual (MAN) modes	61
8.2.2	Fail-safe position (SAFE)	62
8.3	Malfunction/maintenance alarm	62
8.3.1	Confirming error messages	63
9	Maintenance	64
10	Servicing explosion- protected devices	64
11	Code list	65
12	Dimensions in mm	84
12.1	Fixing levels according to VDI/VDE 3845 (September 2010)	86
13	Appendix	87
13.1	Selecting the valve characteristic	87
	Test certificates	89
	Index	98

Note:

- The functions of **EXPERTplus** valve diagnostics are described in the Mounting and Operating Instructions **EB 8389**.
-

Modifications to positioner firmware compared to the previous version	
1.41 (old)	1.42 (new)
	After performing a reset to default values, the allocation of the closing position AIR TO OPEN (AiO) /AIR TO CLOSE (AiC) is not reset to the default setting. The setting is kept.
1.42 (old)	1.51 (new)
	All EXPERTplus diagnostic functions are available in the positioner without having to activate them first (refer to EB 8389 on EXPERTplus valve diagnostics)
	Optional binary input with following actions: <ul style="list-style-type: none"> – Transfer switching state – Set local operation write protection – Switch between AUTO/MAN – Various diagnostic functions (refer to EB 8389 on EXPERTplus valve diagnostics).
	The pressure limit (Code 16) is no longer automatically set during initialization.
1.51 (old)	1.52 (new)
	Internal modifications
1.52 (old)	1.53 (new)
	Internal modifications

1 Important safety instructions

For your own safety, follow these instructions concerning the mounting, start up and operation of the positioner:

- ▶ The positioner is to be mounted, started up or operated only by trained and experienced personnel familiar with the product. According to these Mounting and Operating Instructions, trained personnel refers to individuals who are able to judge the work they are assigned to and recognize possible dangers due to their specialized training, their knowledge and experience as well as their knowledge of the relevant standards.
- ▶ Explosion-protected versions of this positioner may only be operated by personnel who have undergone special training or instructions or who are authorized to work on explosion-protected devices in hazardous areas. Refer to section 10.
- ▶ Any hazards that could be caused by the process medium, the operating pressure, the signal pressure or by moving parts of the control valve are to be prevented by means of the appropriate measures.
- ▶ If inadmissible motions or forces are produced in the actuator as a result of the supply pressure, the supply pressure must be restricted by means of a suitable supply pressure reducing station.

To avoid damage to any equipment, the following also applies:

- ▶ Do not operate the positioner with the back of the positioner/vent opening facing upwards. The vent opening must not be sealed or restricted when the positioner is installed on site.

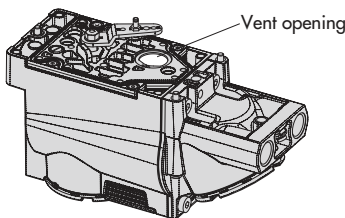

- ▶ Proper shipping and appropriate storage are assumed.
- ▶ Do not ground electric welding equipment near to the positioner.

Note: The device with a CE marking fulfills the requirements of the Directives 2014/30/EU and 2004/108/EC.

The Declaration of Conformity is available on request.

2 Article code

Positioner	Type 3731 - 3	x	x	x	x	x	x	x	0	0	x	1	x	0	0	0
With LCD, autotune, HART® communication																
Explosion protection																
ATEX: II 2G Ex d IIC T6, T5, T4 Gb; II 2G Ex de IIC T6, T5, T4 Gb; II 2D Ex tb IIIC T80°C DB IP 66		2	1													
FM: Class I, Div. 1+2, Groups B, C, D; Class I, Zone 1, Groups IIB+H2; Class I, Div. 1+2 Groups E, F, G; Class III		2	3													
CSA: Class I, Zone 1, Group IIB+H2 T4...T6; Class I, Div. 1+2, Groups B, C, D T4...T6; Class II, Div. 1, Groups E, F, G																
JIS: Ex d IIC T6		2	7													
Options (additional equipment)																
Without										0						
Position transmitter										0						
Binary input										0						
Forced venting										0						
Binary output (NAMUR/PLC)										0						
Diagnostics																
EXPERTplus for control valves															4	
Electrical connections																
2x M20 x 1.5																1
2x ½ NPT																2
Emergency shutdown																
Emergency shutdown with the reference variable of 0 mA*																0
Emergency shutdown when the reference variable is smaller than 3.85 mA																1
Explosion-protection certificates																
As specified in Explosion protection																0
NEPSI: Ex d IIC T6~T4; Ex de IIC T6~T4 (on request)		2	1													1
IECEX: Ex d IIC T6, T5, T4 Gb; Ex de IIC T6, T5, T4 Gb; Ex tb IIIC T80°C Db IP66		2	1													2
GOST: 1Ex d IIC T6/T5/T4 Gb X; 1Ex de IIC T6/T5/T4 Gb X; Ex tb IIIC T 80°C Db X		2	1													3
Special applications																
None																0
Positioner compatible with paint (IP 41/NEMA 1)																1
Special version																
Without																000

* Version no longer available

3 Design and principle of operation

The electropneumatic Ex d positioner is mounted on pneumatic control valves. It is used to assign the valve stem position (controlled variable x) to the control signal (reference variable w). The electric control signal received from a control system is compared to the travel or rotational angle of the control valve, and a signal pressure (output

variable y) is produced for the pneumatic actuator.

The positioner basically consists of an electrical travel sensor system (2), an analog i/p converter (6) with downstream air capacity booster (7) and the electronic unit with a microcontroller (5).

In case of a system deviation, the actuator is either vented or filled with more air. The signal pressure supplied to the actuator can be limited to 1.4 bar, 2.4 bar or 3.7 bar by

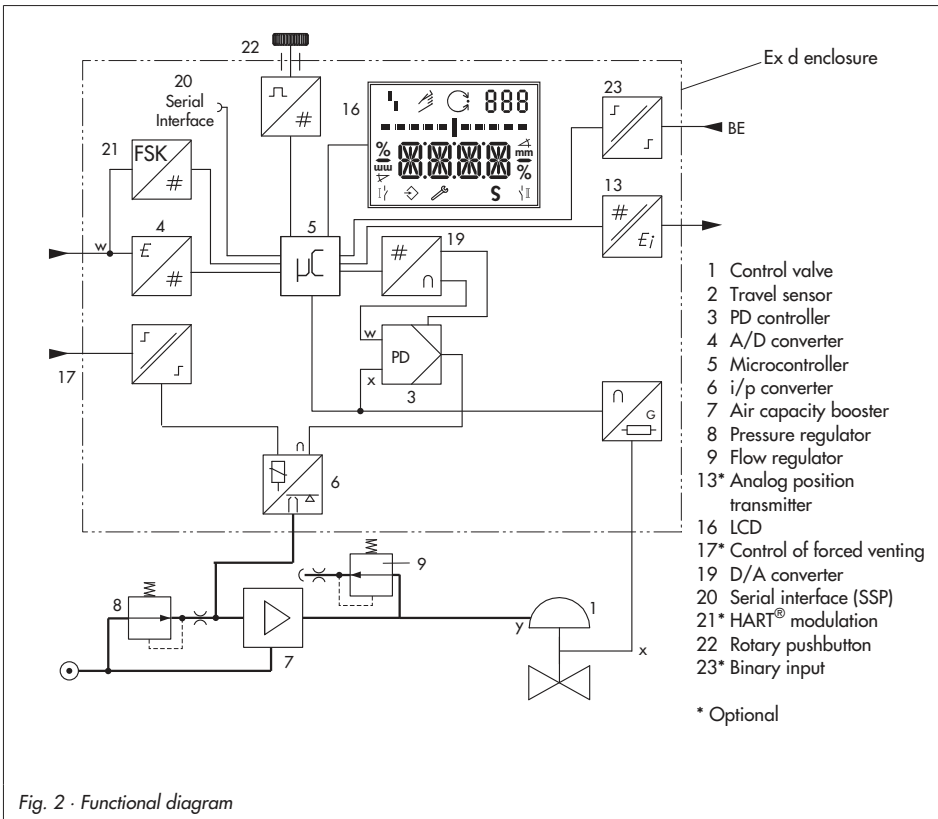

Fig. 2 · Functional diagram

software or on site at the positioner. A constant air stream to the atmosphere is created by the flow regulator (9) with a fixed set point. The air stream is used to purge the inside of the housing as well as to optimize the air capacity booster (7). The i/p converter (6) is supplied with a constant upstream pressure by the pressure regulator (8) to make it independent of the supply pressure.

All parts are enclosed in an Ex d housing. The electrical wires are connected over a separate terminal compartment which is also designed with Ex d protection.

The extended EXPERTplus diagnostics are integrated into the positioner. It provides information on the positioner and generates diagnostic and status messages, which allow faults to be pinpointed quickly.

The positioner is suitable for the following types of attachment using the corresponding accessories:

- ▶ Direct attachment to SAMSON Type 3277 Actuator: section 4.1
- ▶ Attachment to actuators acc. to IEC 60534-6 (NAMUR): section 4.2
- ▶ Attachment to Type 3510 Micro-flow Valve: section 4.3
- ▶ Attachment to rotary actuators acc. to VDI/VDE 3845: section 4.4

3.1 Additional equipment

Forced venting

The i/p converter stops working if the operating voltage supply to the relevant terminals is interrupted. The positioner can no longer operate and the control valve moves to the fail-safe position (SAFE) determined by the actuator, independent of the reference variable.

Binary contact



The positioner has three internal binary signals which can be analyzed over terminals A/B/C. Two of these signals are intended for the valve end positions and one signal for a collective fault alarm. The assignment of these signals to the A/B/C terminals is determined over Code 25.

Position transmitter

The position transmitter (13) is a two-wire transmitter and issues the travel sensor signal as a 4 to 20 mA signal processed by the microcontroller. Since this signal is issued independent of the positioner's input signal (min. current 3.8 mA), the actual travel/angle of rotation is controlled in real-time. Additionally, the position transmitter provides the possibility of signaling a positioner fault over a signal current of 2.4 mA or 21.6 mA.

Binary input

The positioner has an optional binary input. The following actions can be performed over the binary input:

- ▶ **Transfer switching state** [default]
The switching state of the binary input is logged.
- ▶ **Set local operation write protection**
Settings cannot be changed at the positioner while the binary input is active. The configuration enabled function in Code 3 is not active.
- ▶ **Switch between AUTO/MAN**
The positioner changes from automatic mode  (AUTO) mode into manual mode  (MAN) and vice versa. No action is started if the positioner is in the fail-safe position (SAFE).
- ▶ Various diagnostic functions (refer to EB 8389 EN on EXPERTplus valve diagnostics).

Note: The optional binary output can only be configured using the TROVIS-VIEW software and over the DD parameters (refer to EB 8389 on EXPERTplus valve diagnostics). The default switching state is with an open switch.

Connection to terminals A-B: Binary input for DC voltage signals

Connection to terminals B-C: Contact input for an external contact

3.2 Communication

The positioner is equipped with an interface for HART® protocol (Highway Addressable Remote Transducer) for communication purposes. Data are transmitted in a superimposed frequency (FSK = Frequency Shift Keying) on the existing signal loop for the 4 to 20 mA reference variable.

Either a HART® capable handheld communicator or a computer with FSK modem can be used to establish communication and operate the positioner.

3.2.1 Configuration using TROVIS-VIEW software

Refer to Table 5 on page 33 for order numbers.

The positioner can be configured using the TROVIS-VIEW software.

The positioner is equipped for this purpose with an additional digital **SERIAL INTERFACE** to allow a computer to be connected over an adapter cable from the RS-232 or USB port of the computer to the positioner.

The TROVIS-VIEW software enables the user to easily set parameters in the positioner and view process parameters online.

Note: The TROVIS-VIEW software is a common operator interface for various smart SAMSON devices. The software together with a device-specific module allow the configuration and parameterization of the device.

The device-specific module for Type 3731-3 can be downloaded free of charge from the SAMSON website (Services > Software > TROVIS-VIEW).

Additional information on TROVIS-VIEW (e.g. system requirements) can be found on the SAMSON website and in the Data Sheet T 6661.



3.3 Technical data

Type 3731-3 Ex d Positioner (technical data in test certificates additionally apply for explosion-protected devices)		
Rated travel	Adjustable	Direct attachment to Type 3277: 3.6 to 30 mm Attachment acc. to IEC 60534-6 (NAMUR): 3.6 to 200 mm Attachment to rotary actuators (VDI/VDE 3845): 24° to 100°
Travel range	Adjustable	Adjustable within the initialized travel/angle of rotation; travel can be restricted to $\frac{1}{2}$ at the maximum
Reference variable w		Signal range 4 to 20 mA, 2-wire unit, reverse polarity protection, min. span 4 mA, static destruction limit 40 V, internal current limit 60 mA
Shutdown action		Type 3731-3xxxxxx000x1x00: Emergency shutdown at 0 mA Type 3731-3xxxxxx100x1x00: Emergency shutdown at 3.85 mA \pm 0.05 mA
Minimum current		3.6 mA for display Voltage compliance \leq 9 V corresponds to 450 Ω at 20 mA
Communication		
Local communication		SAMSON SSP interface and serial interface adapter
Software requirements		TROVIS-VIEW with device-specific module for Type 3731-3
HART [®] communication		HART [®] field communication protocol Impedance in HART [®] frequency range: Receiving approx. 455 Ω , sending 185 Ω
Software requirements		For handheld communicator: device description for Type 3731-3 For PC: DTM file acc. to Specification 1.2, suitable for integrating the positioner in frame applications that supports the FDT/DTM concept (e.g. PACTware); integration into AMST [™] Suite available.
Supply air	Pressure	Type 3731-321, Type 3731-327: 1.4 to 7 bar (20 to 105 psi) Type 3731-323: 1.4 to 6 bar (20 to 90 psi)
	Air quality acc. to ISO 8573-1 edition 2004	Max. particle size and density: Class 4 · Oil content: Class 3 Moisture and water: Class 3 Pressure dew point: At least 10 K beneath the lowest ambient temperature to be expected
Signal pressure (output)		0 bar up to supply pressure · Limitable to 1.4/2.4/3.7 \pm 0.2 bar via software
Characteristic		Linear/equal percentage/reverse equal percentage Butterfly valve/Rotary plug valve/Segmented ball valve: linear/equal percentage User-defined (over operating software and communication) Deviation from terminal-based conformity \leq 1 %
Hysteresis		\leq 0.3 %
Sensitivity		\leq 0.1%
Transit time		Separately adjustable up to 240 seconds for supply air and exhaust air
Direction of action		Reversible
Air consumption, steady-state		Independent from supply pressure < 110 l _n /h

Type 3731-3 Ex d Positioner (technical data in test certificates additionally apply for explosion-protected devices)		
Air output capacity	to fill actuator with air	At $\Delta p = 6$ bar: $8.5 \text{ m}_n^3/\text{h}$ · At $\Delta p = 1.4$ bar: $3.0 \text{ m}_n^3/\text{h}$ · $K_{V\max}(20 \text{ }^\circ\text{C}) = 0.09$
	to vent actuator	At $\Delta p = 6$ bar: $14.0 \text{ m}_n^3/\text{h}$ · At $\Delta p = 1.4$ bar: $4.5 \text{ m}_n^3/\text{h}$ · $K_{V\max}(20 \text{ }^\circ\text{C}) = 0.15$
Permissible ambient temperature	-40 to 80 °C The limits in the test certificate additionally apply.	
Influences	Temperature: $\leq 0.2/10 \text{ K}$ · Supply air: None Vibration: $\leq 0.25 \%$ up to 2000 Hz and 4 g acc. to IEC 770	
EMC	Complying with the requirements of EN 61000-6-2, EN 61000-6-3, EN 61326-1 and NAMUR Recommendation NE 21	
Electrical connections	Two threaded connections with $\frac{1}{2}$ NPT thread, optionally with M20 x 1.5 Screw terminals for 2.5 mm ² wire cross-section	
Explosion protection	See "Summary of explosion-protection certificates"	
Degree of protection	IP 66/NEMA 4 X	
Use in safety-instrumented systems (SIL)	Observing the requirements of IEC 61508, the systematic capability of the control valve for emergency venting as a component in safety-instrumented systems is given.	
	Use is possible on observing the requirements of IEC 61511 and the required hardware fault tolerance in safety-instrumented systems up to SIL 2 (single device/HFT = 0) and SIL 3 (redundant configuration/HFT = 1).	
Compliance		
Materials	Housing	Die-cast aluminum EN AC-ALSi10Mg(Fe) (EN AC-44300) acc. to DIN EN 1706 chromated and powder paint coating
	External parts	Stainless steel 1.4301/1.4305/1.4310
Weight	Approx. 2.5 kg	

Additional equipment		
Optional binary output, software limit switch, galvanically isolated Connection: Optionally NAMUR EN 60947-5-6 or PLC, configurable as a limit switch or fault alarm output		
Signal status	Terminals B-C Switching output AC/DC (PLC)	Terminals A-B
	Conductive/remaining voltage < 1.7 V	≥ 2.2 mA
	Non-conducting/high resist. I < 100 µA	≤ 1.0 mA
Operating voltage	Switch. capacity: 40 V DC/28 V/AC 0.3 A Static destr. limit: 45 V DC/32 V/AC 0.4 A	Only for connection to NAMUR signal converter acc. to EN 60947-5-6
Optional forced venting, galvanically isolated		
Input	0 to 40 V DC/0 to 28 V AC, static destruction limit 45 V DC/32 V AC, input resistance ≥ 7 kΩ	
Signal	Fail-safe position at an input voltage ≤ 3 V Normal operation at an input voltage > 5.5 V	
Optional analog position transmitter, two-wire transmitter		
Supply voltage	11 to 35 V DC, reverse polarity protection, static destruction limit 45 V	
Output signal	4 to 20 mA	
Direction of action	Reversible	
Operating range	-1.25 to 103 % of the travel range, corresponding to 3.8 to 20.5 mA, optionally also for fault alarm over 2.4 or 21.6 mA acc. to NAMUR Recommendation NE 43	
Characteristic	Linear	
Hysteresis and HF influence	Same as positioner	
Other influences	Same as positioner	
Fault alarm	Can be issued with current signal 2.4 mA or 21.6 mA	
Optional binary input, galvanically isolated, optionally for detection of an externally applied voltage or for operation of an external floating contact · Switching behavior configured as required, default setting (see below)		
Voltage input function, polarity insensitive, 0 to 24 V DC voltage to be applied, input resistance 6.5 kΩ		
Static destruction limit	40 V	
Voltage	> 6 V: Switching state ON · < 4 V: Switching state OFF	
Contact input function, for external switch (floating contact)		
Electrical data	Open-circuit voltage when contact is open: 10 V, pulsed DC current, peak value 100 mA	
Contact	Closed: Switching state ON · Open: Switching state OFF	

Summary of explosion-protection certificates

Type	Certificate			Type of protection/comments
3731	 EC-Type Examination Certificate	Number	PTB 11 ATEX 1014 X	II 2G Ex d IIC T6,T5,T4 Gb; II 2G Ex de IIC T6,T5,T4 Gb; II 2D Ex tb IIIC T80°C DB IP66
		Date	2012-07-26	
		Number	RU C-DE-GB08.B.00697	1Ex d IIC T6/T5/T4 Gb X; 1Ex d e IIC T6/T5/T4 Gb X; Ex tb IIIC T 80°C Db X
		Date	2014-12-15	
		Valid until	2019-12-14	
	IECEX	Number	IECEX PTB 11.0084X	Ex d IIC T6, T5, T4 Gb; Ex d e IIC T6, T5, T4 Gb; Ex tb IIIC T80°C Db IP66
		Date	2011-09-14	
	INMETRO	Number	IEEx 13.0193X	Ex d IIC T* Gb; Ex de IIC T* Gb
		Date	2016-10-14	
		Valid until	2019-08-28	
	KCS	Number	13-KB4BO-0036	Ex d IIC T6/T5/T4
		Date	2013-01-31	
		Valid until	2018-01-31	
	NEPSI	Number	GYJ16.1083X	Ex d IIC T6~T4; Ex de IIC T6~T4
Date		2016-01-24		
Valid until		2023-01-23		
STCC	Number	973	1Ex d IIC T4...T6; 1Ex de IIC T4...T6	
	Valid until	2017-10-01		
-323	CSA	Number	1709815	Class I, Zone 1, Group IIB+H2 T4...T6; Class I, Div. 1+2, Groups B, C, D T4...T6; Class II, Div. 1, Groups E, F, G
		Date	2005-10-04	
	FM	Number	3024956	
		Date	2006-01-30	
-324		Number	RU C-DE-GB08.B.00697	1Ex d IIC T6/T5/T4 Gb X; Ex tb IIIC T 80°C Db X
		Date	2014-12-15	
		Valid until	2019-12-14	
-327	JIS	Number	TC17747	Ex d IIC T6
		Date	2015-09-12	
		Valid until	2018-09-11	

4 Attachment to the control valve – Mounting parts and accessories

WARNING!

Attach the positioner, keeping the following sequence:

1. Mount the positioner on the control valve
2. Connect the supply air
3. Connect the electrical power
4. Perform the start-up settings

The positioner is suitable for the following types of attachment:

- ▶ Direct attachment to SAMSON Type 3277 Actuator
- ▶ Attachment to actuators according to IEC 60534-6 (NAMUR)
- ▶ Attachment to Type 3510 Micro-flow Valve
- ▶ Attachment to rotary actuators

NOTICE

Attach the positioner to the control valve, observing the following instructions to avoid damaging the positioner.

- Use only the mounting parts/accessories listed in the Tables 1 to 5 (pages 30 to 33) to mount the positioner. Observe the type of attachment!
- The positioner is fitted with pneumatic connections with $\frac{1}{4}$ NPT threads. If you need G $\frac{1}{4}$ threads, attach the connecting plate (6) listed in the accessories.
- Observe the assignment between lever and pin position (see travel tables on page 16).

- Fit a signal pressure restriction (Table 5 on page 33) for actuators with diaphragm areas smaller than 240 cm².

Lever and pin position

The positioner is adapted to the actuator and to the rated travel by the lever on the back of the positioner and the pin inserted into the lever.

The travel tables on page 16 show the maximum adjustment range at the positioner. The travel that can be implemented at the valve is additionally restricted by the selected fail-safe position and the required compression of the actuator springs.

The positioner is standard equipped with the lever **M** (pin position **35**).

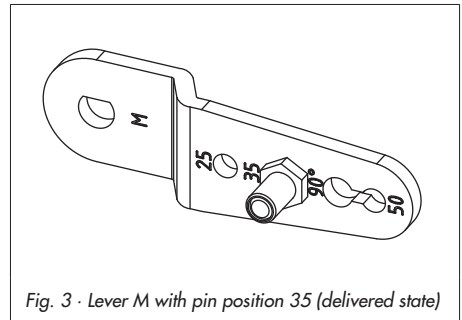

Fig. 3 · Lever M with pin position 35 (delivered state)

Note: If the standard mounted lever M is replaced, the newly mounted lever must be moved once all the way as far as it will go in both directions to adapt it to the internal measuring lever.

Travel tables

Note: The lever **M** is included in the scope of delivery.
Levers **S**, **L**, **XL** for attachment according to IEC 60534-6 (NAMUR) are available as accessories (see Table 3 on page 32).

Direct attachment to Type 3277-5 and Type 3277 Actuators

Actuator size [cm ²]	Rated travel [mm]	Adjustment range at positioner ¹⁾			Required lever	Assigned pin position
		Min.	Travel	Max.		
120	7.5	5.0	to	25.0	M	25
120/175/240/350	15	7.0	to	35.0	M	35
355/700/750	30	10.0	to	50.0	M	50

Attachment according to IEC 60534-6 (NAMUR)

SAMSON valves/Type 3271 Actuator		Adjustment range at positioner ¹⁾			Required lever	Assigned pin position
Actuator size [cm ²]	Rated travel [mm]	Other valves/actuators				
		min.	Travel	max.		
60 and 120 with Type 3510 Valve	7.5	3.6	to	18.0	S	17
120	7.5	5.0	to	25.0	M	25
120/175/240/350	15	7.0	to	35.0	M	35
700/750	7.5					
355/700/750	15 and 30	10.0	to	50.0	M	50
1000/1400/2800	30	14.0	to	70.0	L	70
1000/1400/2800	60	20.0	to	100.0	L	100
1400/2800	120	40.0	to	200.0	XL	200

Attachment to rotary actuators according to VDI/VDE 3845

Rotary actuators				Required lever	Assigned pin position
Min.	Opening angle	Max.			
24	to	100°		M	90°

¹⁾ Values are based on the **NOM initialization** mode

4.1 Direct attachment

4.1.1 Type 3277-5 Actuator

Refer to Table 1 on page 30 for required mounting parts and accessories.

Actuator with 120 cm²

NOTICE

If a solenoid valve or similar is additionally mounted to the actuator, observe the following instructions which differ from the instructions otherwise described:

- The switchover plate (9) is omitted.
- The signal pressure must be routed from the signal pressure output over the connecting plate (accessories order no. 1400-6820) to the actuator.
- The hole for the signal pressure output must be fitted with the screw restriction (accessories order no. 1400-6964/item no. 0390-1424).
- Do not remove the screw plug (4) at the back of the positioner.

Depending on the type of positioner attachment, the signal pressure is routed either left or right of the yoke through a bore to the actuator diaphragm.

1. Refer to Fig. 4 to select the symbol to match the required fail-safe position and how the positioner is attached:
 - Fail-safe position:**
 - Actuator stem extends = Fail-close
 - Actuator stem retracts = Fail-open
 - Positioner attachment:** Left or right with view looking onto the switchover plate

2. Align the marking of the switchover plate (9) to the corresponding symbol and mount the plate on the actuator yoke.
3. If applicable, mount pressure gauge bracket (7) with pressure gauges or, in case G 1/4 threaded connections are required, the connecting plate (6), making sure both seal rings (6.1) are seated properly.
4. Remove screw plug (4) on the back of the positioner and seal the signal pressure output "Output 38" on the connecting plate (6) or on the pressure gauge bracket (7) with the stopper (5) included in the accessories.
5. Place follower clamp (3) on the actuator stem, align and screw it tight so that the mounting screw is located in the groove of the actuator stem.
6. Press brass restriction (accessories order no. 1400-6964/item no. 0390-1423) into the seal of the signal pressure input at the actuator yoke.
7. Mount cover plate (10) with the narrow side of the cut-out opening (Fig. 4, left) pointing towards the signal pressure connection. Make sure that the bonded gasket (14) points towards the actuator yoke.
8. **15 mm travel:** Keep the follower pin (2) at lever **M** (1) on the back of the positioner in the pin position **35** (delivered state).
7.5 mm travel: Remove the follower pin (2) from the pin position **35**, reposition

it in the hole for pin position **25** and screw tight.

9. Insert formed seal (15) into the groove of the positioner housing, pressing the four retaining rings over the housing screws and both fittings into the housing recesses.
10. Thread the bias spring (17) through the crosspiece underneath the lever (1) and push into the hole in the housing. Push the lever (1) until it engages into place. Place positioner on the cover plate (10) and fasten it using the three fixing screws.

Check to make sure that the follower pin (2) rest on top of the follower clamp (3). The lever (1) must rest on the follower clamp with spring force.

Make sure that the seal ring (10.1) is inserted in the borehole of the cover plate.

11. Mount cover (11) on the other side. Make sure that the vent plug (11.1) points downwards when the control valve is installed to allow any condensed water that collects to drain off.

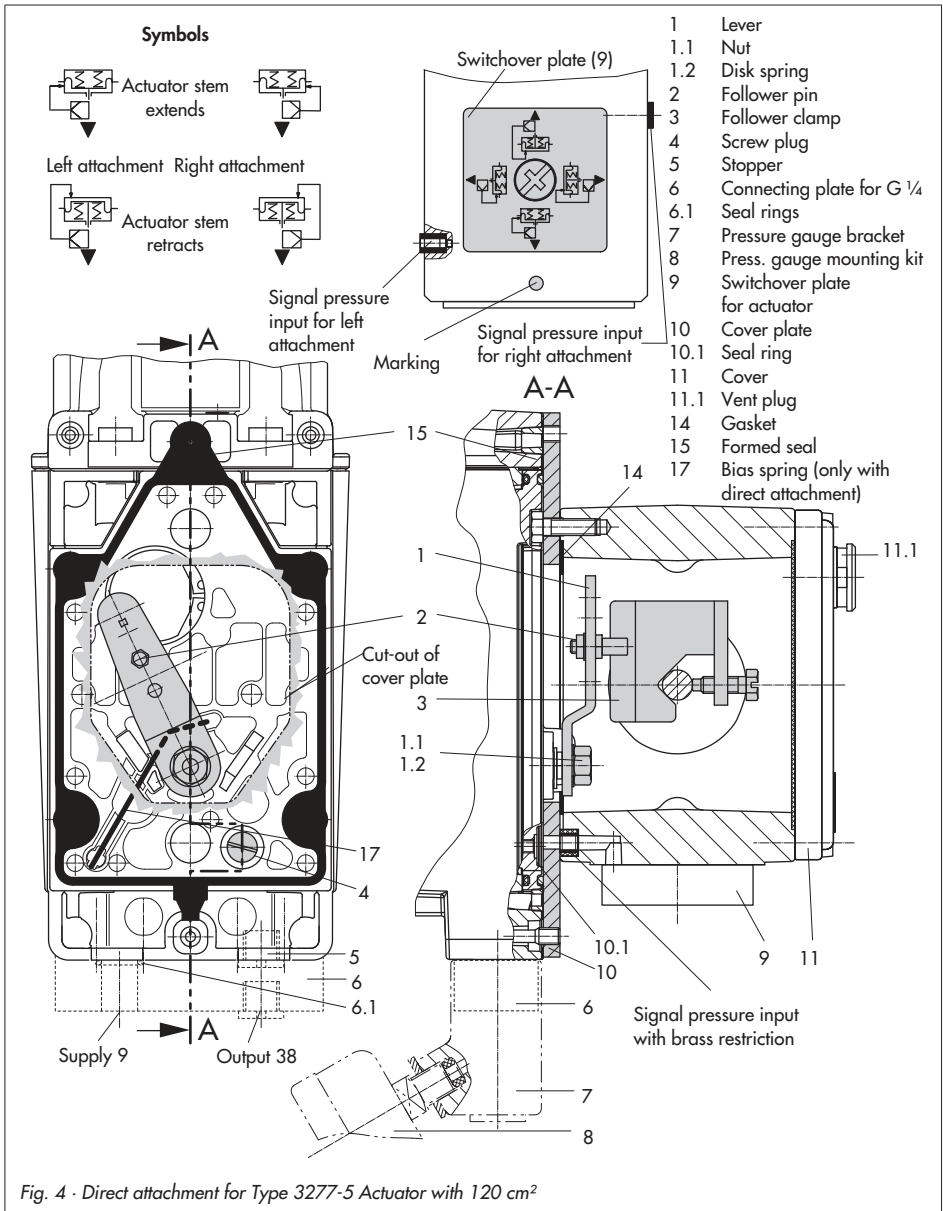

4.1.2 Type 3277 Actuator

Refer to Table 2 on page 31 for the required mounting parts and accessories.

Actuators with 175 to 750 cm²

Mount the positioner onto the yoke as shown in Fig. 5. The signal pressure is routed to the actuator over the connection block (12), for actuators with fail-safe action "Actuator stem extends" internally through a bore in the valve yoke and for "Actuator stem retracts" through external piping.

1. Place follower clamp (3) on the actuator stem, align and screw it tight so that the mounting screw is located in the groove of the actuator stem.
2. Mount cover plate (10) with the narrow side of the cut-out (Fig. 5, left) pointing towards the signal pressure connection. Make sure that the bonded gasket (14) points towards the actuator yoke.
3. **Actuators with 355, 700 and 750 cm²:** Remove the follower pin (2) at lever **M** (1) on the back of the positioner from pin position **35**, reposition it in the hole for pin position **50** and screw tight.
Actuators 175 to 350 cm² with 15 mm travel: The follower pin (2) remains in pin position **35** (delivered state).
4. Insert formed seal (15) into the groove of the positioner housing, pressing the four retaining rings over the housing screws and both fittings into the housing recesses.
5. Thread the bias spring (17) through the crosspiece underneath the lever (1) and push into the hole in the housing. Push the lever (1) until it engages into place. Place positioner on the cover plate (10) and fasten it using three fixing screws. Check whether the follower pin (2) rests on top of the follower clamp (3). The lever (1) must rest on the follower clamp with spring force.
6. Make sure that the tip of the gasket (16) projecting from the side of the connection block (12) is positioned above the actuator symbol that corresponds with the actuator with fail-safe action "Actuator stem extends" or "Actuator stem retracts." If necessary, remove the three fixing screws and the cover plate. Then reposition the gasket (16) turned by 180°. The previous version of the connection block (Fig. 5, bottom) requires the switch plate (13) to be turned such that the corresponding actuator symbol points to the marking.
7. **Actuators with 175 cm²:** Unscrew the filter from the signal pressure input and first screw the screw restriction (accessories order no. 1400-6964/item no. 0390-1424) into the input and then the filter.
8. Place the connection block (12) with the associated seal rings against the positioner and the actuator yoke. Screw it tight using the fixing screw (12.1). For actuators with fail-safe action "Actuator stem retracts", additionally remove the stopper (12.2) and attach the external signal pressure line.

- | | |
|--------------------|--|
| 1 Lever | 12 Connection block |
| 1.1 Nut | 12.1 Screw |
| 1.2 Disk spring | 12.2 Stopper or connection for external piping |
| 2 Follower pin | 13 Switch plate |
| 3 Follower clamp | 14 Gasket |
| 10 Cover plate G ¼ | 15 Formed seal |
| 11 Cover | 16 Gasket |
| 11.1 Vent plug | 17 Bias spring (only for direct attachment) |

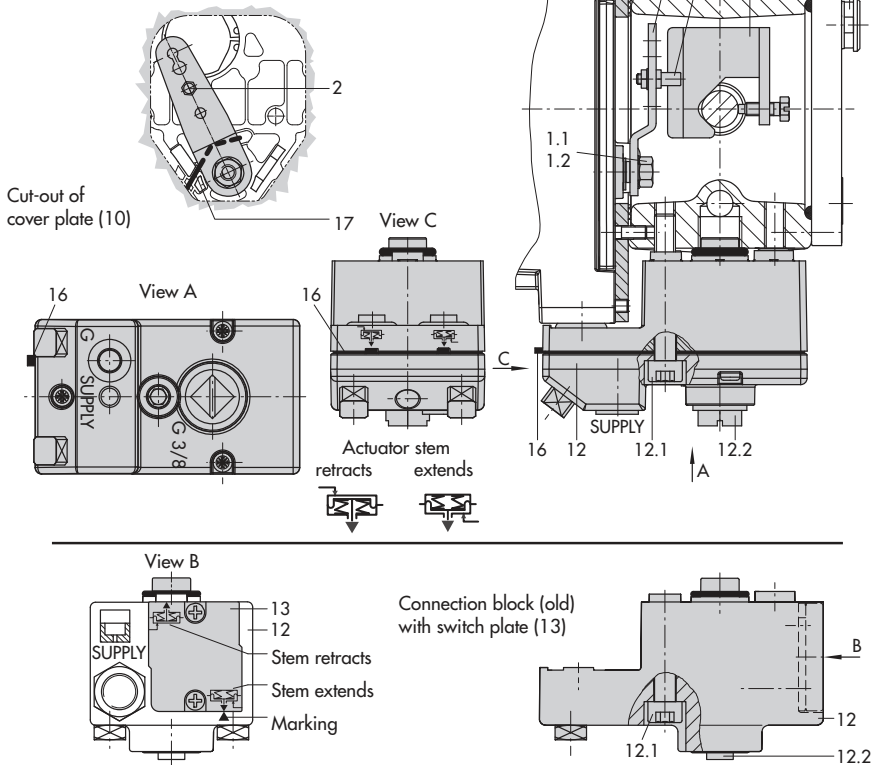

Fig. 5 - Direct attachment – Signal pressure connection for Type 3277 Actuator with 175 to 750 cm²

9. Mount cover (11) on the other side. Make sure that the vent plug (11.1) points to the back when the control valve is installed to allow any condensed water that collects to drain off.

4.2 Attachment according to IEC 60534-6 (NAMUR)

Refer to Table 3 on page 32 for the required mounting parts and accessories.

The positioner is attached to the control valve using a NAMUR bracket (10).

1. **Actuator with 175 cm²:**
Unscrew the filter from the signal pressure input and first screw the screw restriction (accessories order no. 1400-6964/item no. 0390-1424) into the input and then the filter.
2. **Actuator sizes 120 to 750 cm²:**
Screw the two bolts (14) to the bracket (9.1) of the stem connector (9), place the follower plate (3) on top and tighten it using the screws (14.1).
Actuator size 2800 cm² and 1400 cm² (120 mm travel):
 - For a travel of 60 mm or smaller, screw the longer follower plate (3.1) directly to the stem connector (9).
 - For a travel exceeding 60 mm, mount the bracket (16) first and then the follower plate (3) to the bracket together with the bolts (14) and screws (14.1).
3. Mount NAMUR bracket (10) to the control valve as follows:
 - For attachment to the NAMUR rib, use an M8 screw (11), washer and toothed lock washer directly in the yoke bore.
 - For attachment to valves with rod-type yokes, use two U-bolts (15) around the yoke. Align the NAMUR bracket (10) in such a way that the slot of the follower plate (3/3.1) is centrally aligned with the NAMUR bracket at mid valve travel.
4. If applicable, mount pressure gauge bracket (7) with pressure gauges or, in case G ¼ threaded connections are required, the connecting plate (6), making sure both seal rings (6.1) are seated properly.
5. Screw a screw restriction (accessories order no. 1400-6964/item no. 0390-1424) into the signal pressure output for actuators with diaphragm areas smaller than 240 cm².
6. Select required lever (1) size **M**, **L** or **XL** and pin position according to the actuator size and valve travels listed in the table on page 16.
Lever M with pin position 25 or 50:
 - 6.1 Remove follower pin (2) from pin position **35** and screw it into the required hole.**Lever L or XL:**
 - 6.1 Unscrew the standard lever **M** from the shaft of the positioner.

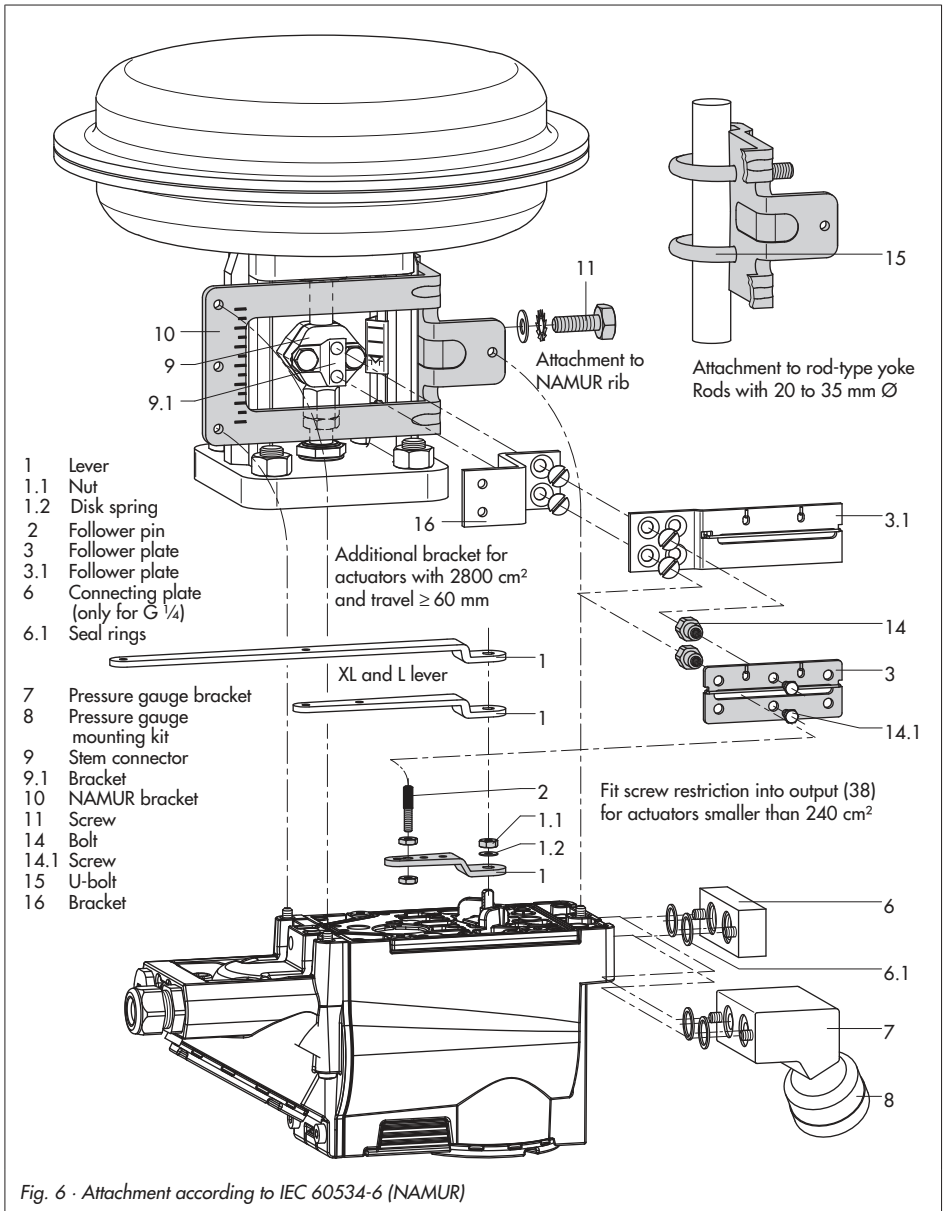

- 6.2 Screw the long follower pin (2) included in the mounting kit in the pin position of the required lever (1) assigned in the table.
- 6.3 Place lever (1) on the positioner shaft and screw tight using the disk spring (1.2) and nut (1.1).
- 6.4 Move the lever once all the way as far as it will go in both directions.
7. Place positioner on the NAMUR bracket in such a manner that the follower pin (2) rests in the slot of the follower plate (3/3.1). Adjust the lever (1) correspondingly. Screw the positioner to the NAMUR bracket using three fixing screws.

4.3 Attachment to Type 3510 Micro-flow Valve

Refer to Table 3 on page 32 for the required mounting parts and accessories.

The positioner is attached to the valve yoke using a bracket.

1. Mount the travel indication scale (accessories) onto the outer side of the yoke using the hex screws (12.1), ensuring that the scale is aligned with the stem connector.
2. Fasten the bracket (9.1) onto the stem connector.
3. Fasten the two pins (9.2) to the bracket (9.1) on the stem connector. Mount the follower plate (3) and fasten it using the screws (9.3).
4. Fasten the hex bar (11) onto the outer side of yoke by screwing the M8 screws (11.1) directly into the holes on the yoke.
5. Fasten the bracket (10) to the hex bar (11) using the hex screw (10.1), washer and tooth lock washer.
6. If applicable, mount pressure gauge bracket (7) with pressure gauges or, in case G ¼ threaded connections are required, the connecting plate (6), making sure both seal rings (6.1) are seated properly.
7. Screw the restriction (accessories order no. 1400-6964/item no. 0390-1424) into the signal pressure output of the positioner (or output of the pressure gauge bracket or connecting plate).
8. Unscrew the standard installed lever **M** (1) including follower pin (2) from the positioner shaft.
9. Take lever **S** (1) and screw follower pin (2) in the bore for pin position **17**.
10. Place lever **S** on the positioner shaft and screw tight using the disk spring (1.2) and nut (1.1).
Move the lever once all the way as far as it will go in both directions.
11. Place positioner on the bracket (10) in such a manner that the follower pin slides into the groove of the clamp (3). Adjust the lever (1) correspondingly. Screw the positioner to the bracket (10) using both its screws.

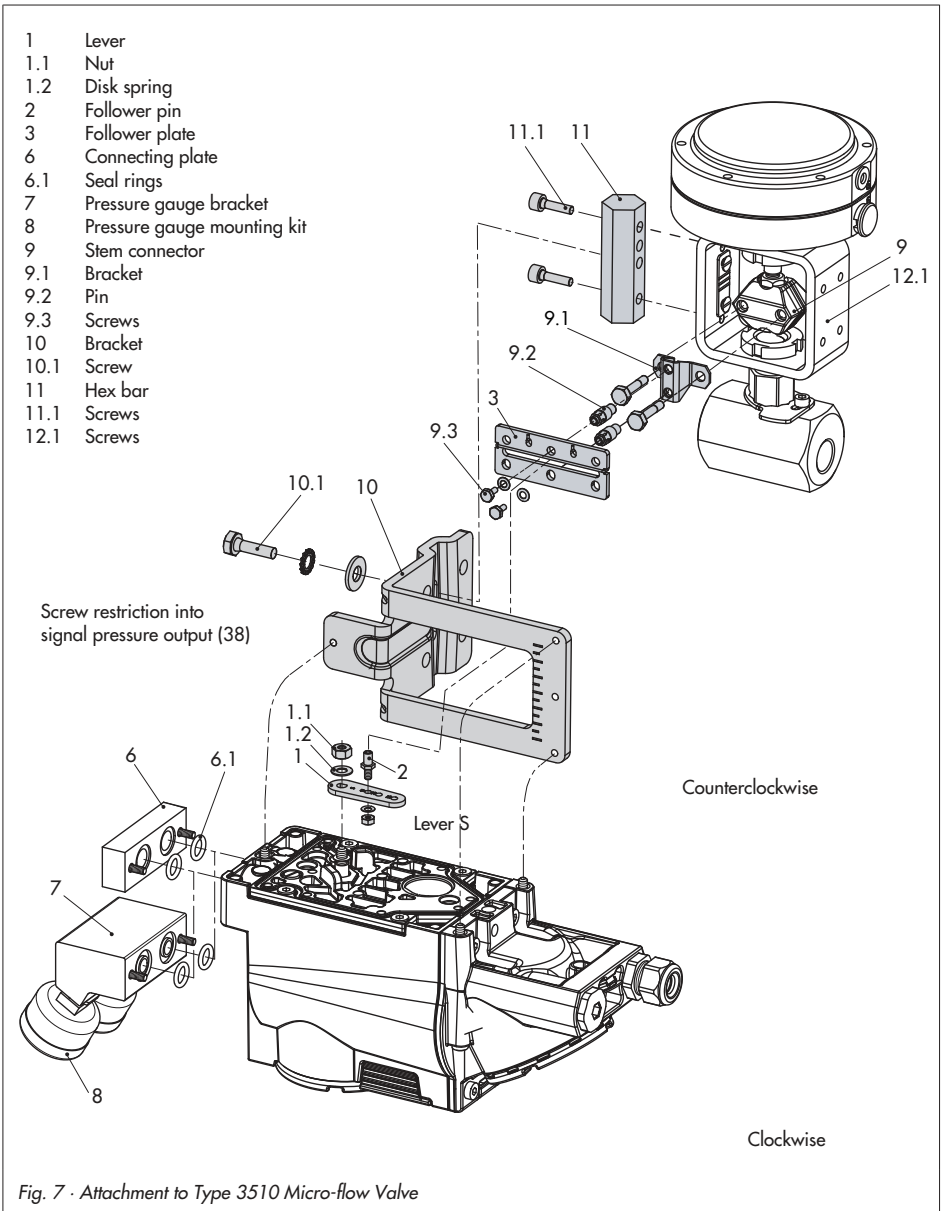

Fig. 7 · Attachment to Type 3510 Micro-flow Valve

4.4 Attachment to rotary actuators

Refer to Table 4 on page 33 for the required mounting parts and accessories.

Both mounting kits contain all the necessary mounting parts. First select correct actuator size. Prepare actuator, and mount required adapter supplied by the actuator manufacturer, if necessary.

1. Mount the housing (10) onto the rotary actuator. In case of VDI/VDE attachment, place spacers (11) underneath, if necessary.
2. **For SAMSON Type 3278 and VETEC S160 Rotary Actuator**, screw the adapter (5) onto the free end of the shaft or place adapter (5.1) onto the shaft of the **VETEC R Actuator**. Place adapter (3) onto **Type 3278, VETEC S160 and VETEC R Actuator**. For **VDI/VDE version**, this step depends on the actuator size.
3. Stick adhesive label (4.3) onto the coupling wheel in such a manner that the yellow part of the sticker is visible in the window of the housing when the valve is OPEN. Adhesive labels with explanatory symbols are enclosed and can be stuck on the housing, if required.
4. Screw tight coupling wheel (4) onto the slotted actuator shaft or adapter (3) using screw (4.1) and disk spring (4.2).
5. Undo the standard follower pin (2) on the lever M (1) of the positioner. Attach the follower pin ($\varnothing 5$) included in the mounting kit to pin position 90° .
6. If applicable, mount pressure gauge bracket (7) with pressure gauges or, in case G $\frac{1}{4}$ threaded connections are required, the connecting plate (6), making sure both seal rings (6.1) are seated properly.
For double-acting, springless rotary actuators, a reversing amplifier is required to attach the positioner to the actuator. Refer to section 4.5.
7. For actuators with a volume of less than 300 cm^3 , screw the screw restriction (accessories order no.1400-6964/item no. 0390-1424) into the signal pressure output of the positioner (or the output of the pressure gauge bracket or connecting plate).
8. Place positioner on housing (10) and screw it tight. Considering the actuator's direction of rotation, align lever (1) so that it engages in the correct slot of the coupling wheel with its follower pin (Fig. 8).

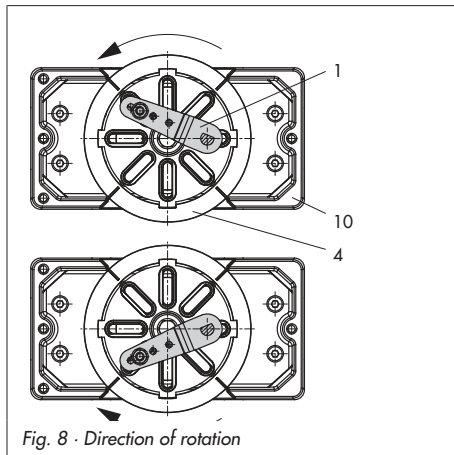

Fig. 8 · Direction of rotation

- 1 Lever
- 1.1 Nut
- 1.2 Disk spring
- 2 Follower pin
- 3 Adapter
- 4 Coupling wheel
- 4.1 Screw
- 4.2 Disk spring
- 4.3 Adhesive label
- 5 Actuator shaft or adapter
- 5.1 Adapter
- 6 Connecting plate (only for G 1/4)
- 6.1 Seal rings
- 7 Pressure gauge bracket
- 8 Pressure gauge mounting kit
- 10 Adapter housing
- 10.1 Screws
- 11 Spacers

Fit screw restriction into signal pressure output for actuators with <math>< 300 \text{ cm}^3</math> volume

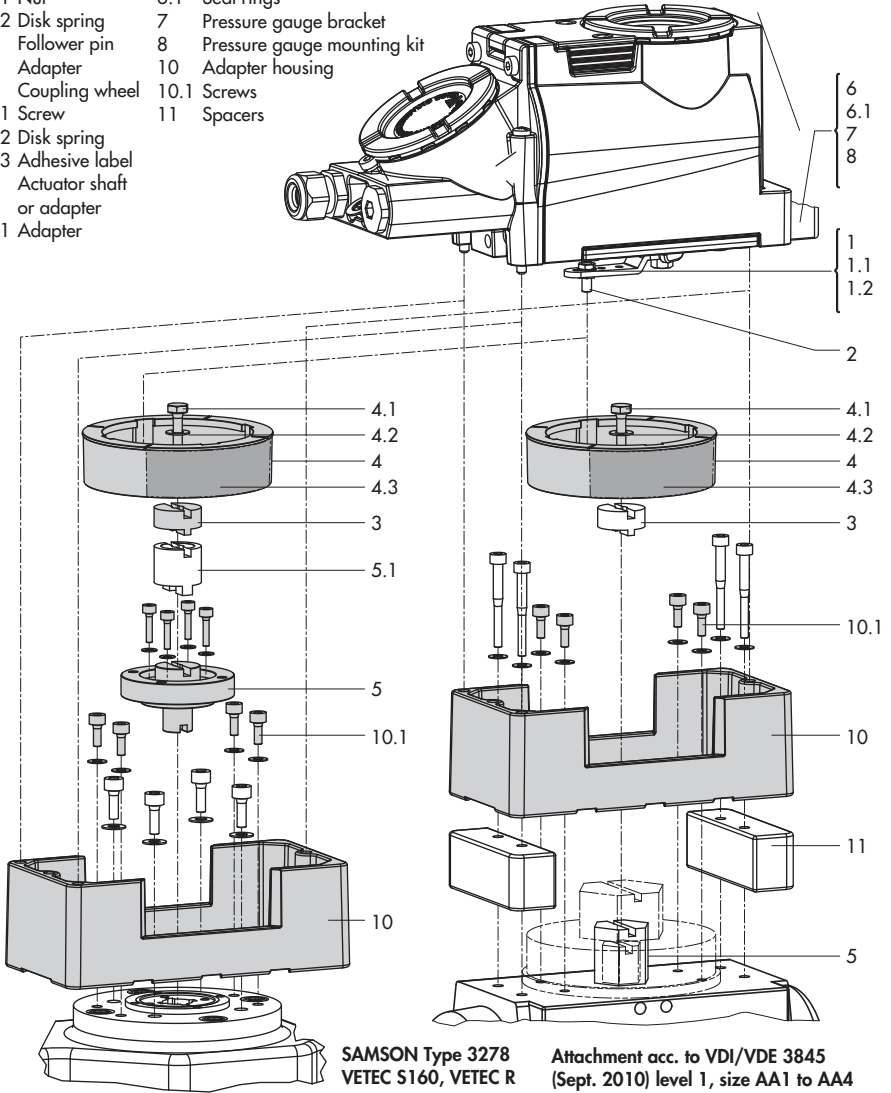

Fig. 9 - Attachment to rotary actuators

4.5 Reversing amplifier for double-acting actuators

For the use with double-acting actuators, the positioner must be fitted with a reversing amplifier, e.g. the SAMSON Type 3710 Reversing Amplifier (see Mounting and Operating Instructions EB 8392 EN).

If a different reversing amplifier (item no. 1079-1118 or 1079-1119) is used, follow the mounting instructions described in section 4.5.1.

The following applies to all reversing amplifiers:

The output signal pressure of the positioner is supplied at the output **A₁** of the reversing amplifier. An opposing pressure, which equals the required supply pressure when added to the pressure at **A₁**, is applied at output **A₂**.

The rule **A₁ + A₂ = Z** applies.

A₁: Output **A₁** leading to the signal pressure connection at the actuator which opens the valve when the pressure increases

A₂: Output **A₂** leading to the signal pressure connection at the actuator which closes the valve when the pressure increases

4.5.1 Reversing amplifier (1079-1118 or 1079-1119)

NOTICE

Do not unscrew sealing plug (1.5) out of the reversing amplifier.

1. Thread the special nuts (1.3) from the accessories of the reversing amplifier into the boreholes of the positioner. Remove the rubber seal (1.4).
2. Insert the gasket (1.2) into the recess of the reversing amplifier and push both the hollowed special screws (1.1) into the connecting boreholes **A₁** and **Z**.
3. Position the reversing amplifier (1) and screw tight using both the special screws (1.1).
4. Use a screwdriver (8 mm wide) to screw the enclosed filters (1.6) into the connecting boreholes **A₁** and **Z**.

NOTICE

On start up of double-acting actuators, the following settings as described in section 7 must be made:

- Pressure limit (Code **16**) = **No**
- Fail-safe position (Code **0**) = **A₁O** (AIR TO OPEN)

Pressure gauge attachment

The mounting sequence shown in Fig. 10 remains unchanged. Screw a pressure gauge bracket onto the connections **A₁** and **Z**.

Pressure gauge	G ¼	1400-7106
bracket:	¼ NPT	1400-7107

Pressure gauges for supply air Z and output **A₁** as listed in Tables 1 to 4.

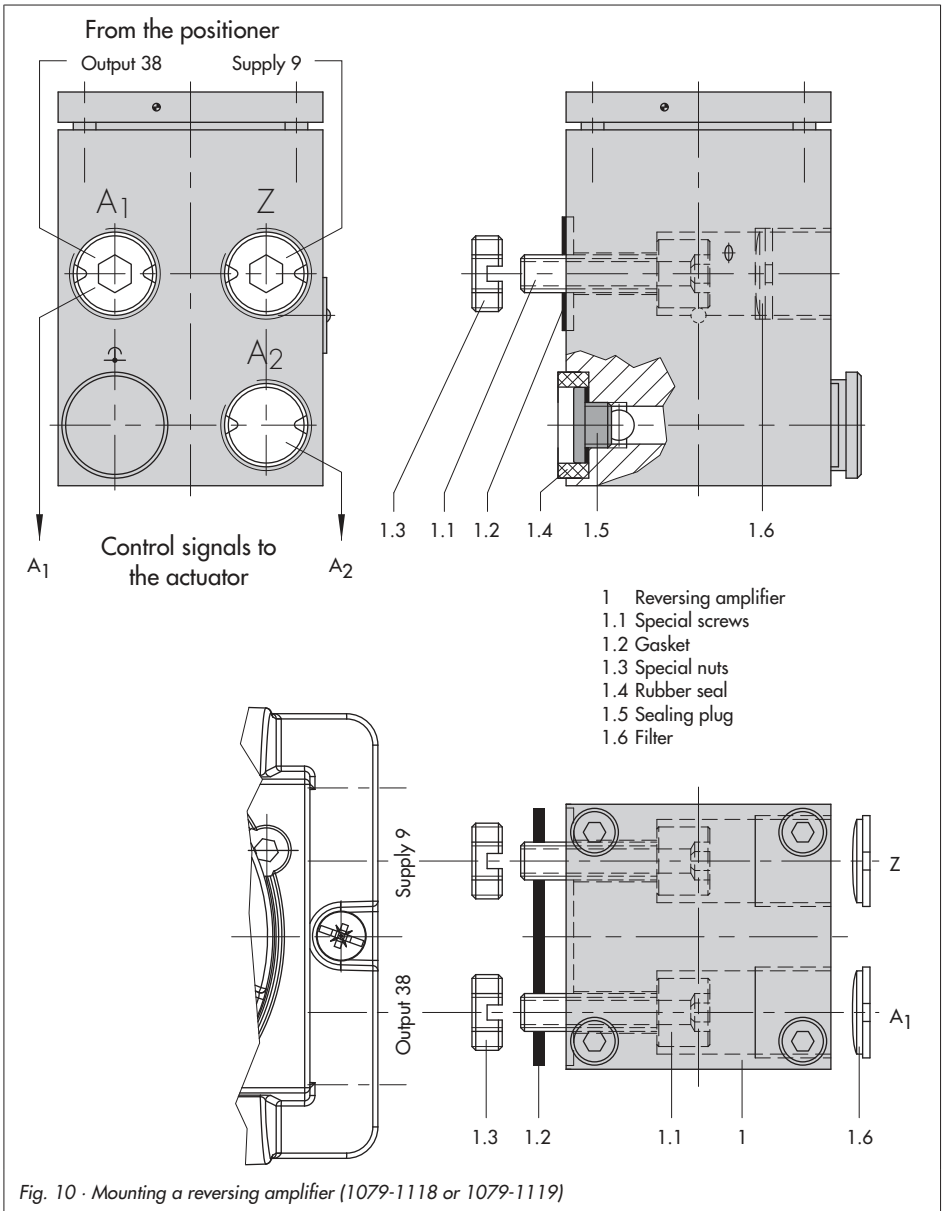

4.6 Required mounting parts and accessories

Table 1 · Direct attachment to Type 3277-5 (Fig. 4)			Order no.
Mounting parts	For actuators with 120 cm ² effective diaphragm area		1400-7452
	Version compatible with paint for actuators 120 cm ² or smaller		1402-0940
Accessories for the actuator	Switchover plate (old) for Actuator Type 3277-5xxxxx. 00 (old)		1400-6819
	Switchover plate new for Actuator Type 3277-5xxxxx. 01 (new) ¹⁾		1400-6822
	Connecting plate new for Actuator Type 3277-5xxxxx. 01 (new) ¹⁾ , G ½ and ⅜ NPT		1400-6823
	Connecting plate old for Actuator Type 3277-5xxxxx. 00 (old): G ⅝		1400-6820
	Connecting plate old for Actuator Type 3277-5xxxxx. 00 (old): ⅜ NPT		1400-6821
Accessories for the positioner	Connecting plate (6)	G ¼	1400-7461
	Pressure gauge bracket (7)	G ¼	1400-7458
		¼ NPT	1400-7459
	Pressure gauge mounting kit (8) up to max. 6 bar (output/supply)	St. st./Brass	1402-0938
		St. st./St. st.	1402-0939

¹⁾ Only new switchover and connecting plates can be used with new actuators (Index 01).
Old and new plates are **not** interchangeable.

Table 2 · Direct attachment to Type 3277 (Fig. 5)					Order no.	
Mounting parts	Standard version for actuators with 175, 240, 350, 355, 700, 750 cm ²				1400-7453	
Accessories	Required piping with screw fitting – for "Actuator stem retracts" – with air purging of the top diaphragm chamber	175 cm ²	Steel	G ¼ / G ⅜	1402-0970	
				¼ NPT / ⅜ NPT	1402-0976	
			Stainl. steel	G ¼ / G ⅜	1402-0971	
				¼ NPT / ⅜ NPT	1402-0978	
		240 cm ²	Steel	G ¼ / G ⅜	1400-6444	
				¼ NPT / ⅜ NPT	1402-0911	
			Stainl. steel	G ¼ / G ⅜	1400-6445	
				¼ NPT / ⅜ NPT	1402-0912	
		350 cm ²	Steel	G ¼ / G ⅜	1400-6446	
				¼ NPT / ⅜ NPT	1402-0913	
			Stainl. steel	G ¼ / G ⅜	1400-6447	
				¼ NPT / ⅜ NPT	1402-0914	
		355 cm ²	Steel	G ¼ / G ⅜	1402-0972	
				¼ NPT / ⅜ NPT	1402-0979	
			Stainl. steel	G ¼ / G ⅜	1402-0973	
				¼ NPT / ⅜ NPT	1402-0980	
		700 cm ²	Steel	G ¼ / G ⅜	1400-6448	
				¼ NPT / ⅜ NPT	1402-0915	
			Stainl. steel	G ¼ / G ⅜	1400-6449	
				¼ NPT / ⅜ NPT	1402-0916	
		750 cm ²	Steel	G ¼ / G ⅜	1402-0974	
				¼ NPT / ⅜ NPT	1402-0981	
			Stainl. steel	G ¼ / G ⅜	1402-0975	
				¼ NPT / ⅜ NPT	1402-0982	
		Connection block with seals and screw			G ¼	1400-8819
					¼ NPT	1402-0901
		Pressure gauge mounting kit (8) up to max. 6 bar (output/supply)			Steel/brass	1402-0938
					St. steel/St. steel	1402-0939

Table 3 · Attachment to NAMUR ribs or control valves with rod-type yokes (20 to 35 mm rod diameter) according to IEC 60534-6 (Figs. 6 and 7)			Order no.
Travel in mm	Lever	For actuators	
7.5	S	Type 3271-5 Actuator with 60/120 cm ² on Type 3510 Valve (Fig. 7)	1402-0478
5 to 50	M ¹⁾	Actuators from other manufacturers and Type 3271 with 120 to 750 cm ²	1400-7454
14 to 100	L	Actuators from other manufacturers and Type 3271, versions 1000 and 1400-60	1400-7455
40 to 200	XL	Actuators from other manufacturers and Type 3271, versions 1400-120 and 2800 cm ² with 120 mm travel	1400-7456
30 or 60	L	Type 3271, versions 1400-120 and 2800 cm ² (30 or 60 mm travel)	1400-7466
		Mounting bracket for Emerson and Masoneilan linear actuators; a mounting kit acc. to IEC 60534-6 is necessary depending on the travel (see above)	1400-6771
		Valtek Type 25/50	1400-9554
Accessories	Connecting plate (6)	G ¼	1400-7461
		¼ NPT	1400-7462
	Pressure gauge bracket (7)	G ¼	1400-7458
		¼ NPT	1400-7459
	Pressure gauge mounting kit (8) up to max. 6 bar (output/supply)	St. st./Brass	1402-0938
		St. steel/St. st.	1402-0939

Table 4 · Attachment to rotary actuators (Figs. 8 and 9)			Order no.
Mounting parts	Attachment acc. to VDI/VDE 3845 (September 2010), see section 12.1 for details		
	Actuator surface corresponds to level 1		
	Size AA1 to AA4, heavy-duty version		1400-9244
	Size AA5, heavy-duty version (e.g. Air Torque 10 000)		1400-9542
	Bracket surface corresponds to level 2, heavy-duty version		1400-9526
	Attachment for SAMSON Type 3278 with 160 cm ² and for VETEC Type S160, R and M, heavy-duty version		1400-9245
Accessories	Attachment for SAMSON Type 3278 with 320 cm ² and for VETEC Type S320, heavy-duty version		1400-5891 and 1400-9526
	Attachment to Camflex II		1400-9120
	Accessories	Connecting plate (6)	G ¼
¼ NPT			1400-7462
Pressure gauge bracket (7)		G ¼	1400-7458
		¼ NPT	1400-7459
Pressure gauge mounting kit up to max. 6 bar (output/supply)		St. steel/brass	1402-0938
		St. steel/st. steel	1402-0939

Table 5 · General accessories			
Accessories	Pneumatic reversing amplifier for double-acting actuators		Type 3710
	Signal pressure restrictions (screw restriction (item no. 0390-1424) and brass restriction (item no. 0390-1423))		1400-6964
	TROVIS-VIEW with device-specific module for Type 3731-3 (refer to section 3.2.1)		
	Serial interface adapter (SAMSON SSP interface – RS-232 port on computer)		1400-7700
	Isolated USB interface adapter (SAMSON SSP interface – USB port on computer) including TROVIS-VIEW CD-ROM		1400-9740

5 Connections

WARNING!

Mount the positioner, keeping the following sequence:

1. Mount the positioner on the control valve
2. **Connect the supply air**
3. **Connect the electrical power**
4. Perform the start-up settings

The connection of the electrical auxiliary power may cause the actuator stem to move, depending on the operating mode. Do not touch the actuator stem or obstruct it to avoid risk of injury to hands or fingers.

5.1 Pneumatic connections

The maximum input pressure (supply pressure) is:

- 7 bar for Types 3731-321 and 3731-327
- 6 bar for Type 3731-323

DANGER!

Danger from the formation of an explosive atmosphere!

The operator of the apparatus must ensure that the working medium cannot form an explosive atmosphere, i.e. only such gases may be used which are free from substances whose presence in the medium might lead to the formation of an explosive atmosphere (e.g. do not use flammable gases, oxygen or oxygen-enriched gases).

Follow the instructions below to avoid damaging the positioner.

- The screw fittings with ¼ NPT thread can be screwed directly into the positioner. In case G ¼ threaded connections are required, the fittings must be screwed into the connecting plate (6) or pressure gauge mounting block or connection block available from the accessories. Customary screw-in fittings for metal and copper pipes or plastic hoses can be used.
- The supply air must be dry and free from oil and dust. The maintenance instructions for upstream pressure reducing stations must be observed. Blow through all air pipes and hoses thoroughly prior to connecting them.

If the positioner is attached directly to the Type 3277 Actuator, the connection of the positioner's output pressure to the actuator is fixed. For attachment according to IEC 60534-6 (NAMUR), the signal pressure can be routed to either the top or bottom diaphragm chamber of the actuator, depending on the actuator's fail-safe action "Actuator stem extends" or "Actuator stem retracts".

For rotary actuators, the manufacturer's specifications for connection apply.

5.1.1 Signal pressure gauges

To monitor the supply air (Supply) and signal pressure (Output), we recommend that pressure gauges be attached (see accessories in Tables 1 to 5).

5.1.2 Supply pressure

The required supply pressure (of supply air) depends on the bench range and the actuator's operating direction (fail-safe action). The bench range is registered on the nameplate either as spring range or signal pressure range depending on the actuator. The direction of action is marked **FA** or **FE**, or by a symbol.

Actuator stem extends FA (AIR TO OPEN)

Fail-close (for globe and angle valves):
Required supply pressure = Upper bench range value + 0.2 bar, minimum 1.4 bar.

Actuator stem retracts FE (AIR TO CLOSE)

Fail-open (for globe and angle valves):
For tight-closing valves, the maximum signal pressure $p_{st_{max}}$ is roughly estimated as follows:

$$p_{st_{max}} = F + \frac{d^2 \cdot \pi \cdot \Delta p}{4 \cdot A} \text{ [bar]}$$

d = Seat diameter [cm]

Δp = Differential pressure across the valve [bar]

A = Actuator diaphragm area [cm²]

F = Upper bench range of the actuator [bar]

If there are no specifications, calculate as follows:

Required supply pressure =
Upper bench range value + 1 bar

5.1.3 Signal pressure (output)

The signal pressure at the output (Output 38) of the positioner can be limited to 1.4, 2.4 or 3.7 bar in Code 16.

The limitation is not activated [No] by default.

5.2 Electrical connections



DANGER!

Risk of the formation of an explosive atmosphere!

- ▶ *The following standard applies for assembly and installation in hazardous areas: **EN 60079-14** (VDE 0165 Part 1) **Explosive atmospheres - Electrical installations design, selection and erection.***

Connection to conform with the type of protection Ex d (EN 60079-1):

The Type 3731-321 Positioner must be connected over the appropriate cable glands or conduit systems which meet the requirements of EN 60079-1 (Electrical apparatus for explosive gas atmospheres - Part 1: Flameproof enclosures "d") Clauses 13.1 and 13.2 and for which a special test certificate exists.

Do not use simple types of cable glands or blanking plugs.

Seal any cable entries that are not used using blanking plugs approved for this purpose for installations according to the type of protection Ex db.

Install the connecting line rigidly and ensure it is protected adequately from being damaged. In case the temperature exceeds 70 °C at the cable entries, use appropriate temperature-resistant connecting cables.

Integrate the positioner into the equipotential bonding system on site.

Connection to conform with the type of protection Ex e (EN 60079-7):

The cable and cable entries or blanking plugs must be certified according to the type of protection Ex e (ATEX) and for which a special test certificate exists.

Devices used at ambient temperatures below -20 °C must have metal cable entries.

In cases where more than one cable core is connected to the same terminal, make sure that each cable core is clamped adequately.

Two cables with varying cross-sections may only be connected to one terminal, if this is not explicitly allowed in the documentation related to the electrical apparatus, when the two cables are secured with a common crimp sleeve beforehand.

Connection to conform with the type of protection Ex i (EN 60079-11):

For connection to a certified, external intrinsically safe circuit, the terminal compartment of the positioner may be opened within the hazardous area.

Only the terminal compartment is to be opened within the hazardous area to connect it to a certified intrinsically safe circuit.

Positioners that are connected to non-intrinsically safe circuits are no longer permitted to be used as intrinsically safe equipment.

The IP rating of the cable, cable entries and blanking plugs must be the same as the positioner's degree of protection.

Table 6 · Accessories		Order no.
Cable gland M20 x 1.5; EEx e, black plastic		8808-0178
Blanking plugs; EEx de; stainless steel (approvals: CENELEC, CSA, GOST, IECEX)	M20 x 1.5	8323-1203
	½ NPT	8323-1204
Cable entry for unarmored cables; EEx e, EEx d, EEx tD A21 (approvals: CENELEC, IECEX)	M20 x 1.5	8808-0200
	½ NPT	8808-2010

Cable entry

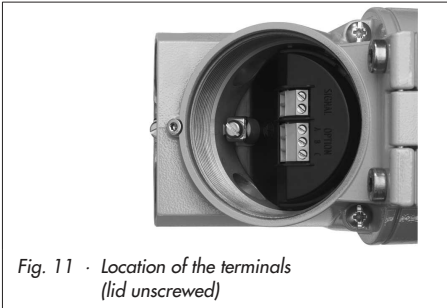

Fig. 11 · Location of the terminals
(lid unscrewed)

The threaded connections for the terminal compartment are designed with $\frac{1}{2}$ NPT or M20x1.5 threads.

The electrical connections are screw terminals for wire cross-sections of 0.2 to 2.5 mm² using a tightening torque of at least 0.5 Nm.

The wires for the reference variable are to be routed to the enclosure terminals marked **Signal** and are polarity insensitive.

- ▶ If the reference variable exceeds 22 mA, **OVERLOAD** appears on the LC display as a warning.
- ▶ If the reference variable falls below 3.7 mA, **LOW** appears on the LC display as a warning.

Depending on the version, the positioner is equipped with an additional binary output, a forced venting function, a position transmitter or a binary input.

The position transmitter is operated in a two-wire circuit. The usual supply voltage is 24 V DC. Considering the resistance of the supply leads, the voltage at the position transmitter terminals can be between 11 V at the minimum and 35 V DC at the maxi-

mum (reverse polarity protection, see Technical data).

NOTICE

The demanded degree of protection might not be met because the terminal compartment is not sealed tightly. Only operate the positioner with sealed cable entries and with the lid screwed on properly.

NOTICE

Loss of explosion protection due to damaged lid thread and/or connecting thread. Do not open the flameproof enclosure when the positioner is in the energized state. Observe explosion protection regulations.

1. Unscrew lid.
2. Guide the wires through the side cable entry to the terminal compartment using a cable gland or conduit system.
3. Connect wires to the terminals as shown in the wiring diagram (Fig. 12).
4. Check O-ring for damage and replace it with a new one, if necessary.
5. Screw on the lid as far as it will go. Turn it back to first safety position (notch).
6. Unscrew the cap screw to lock the lid.

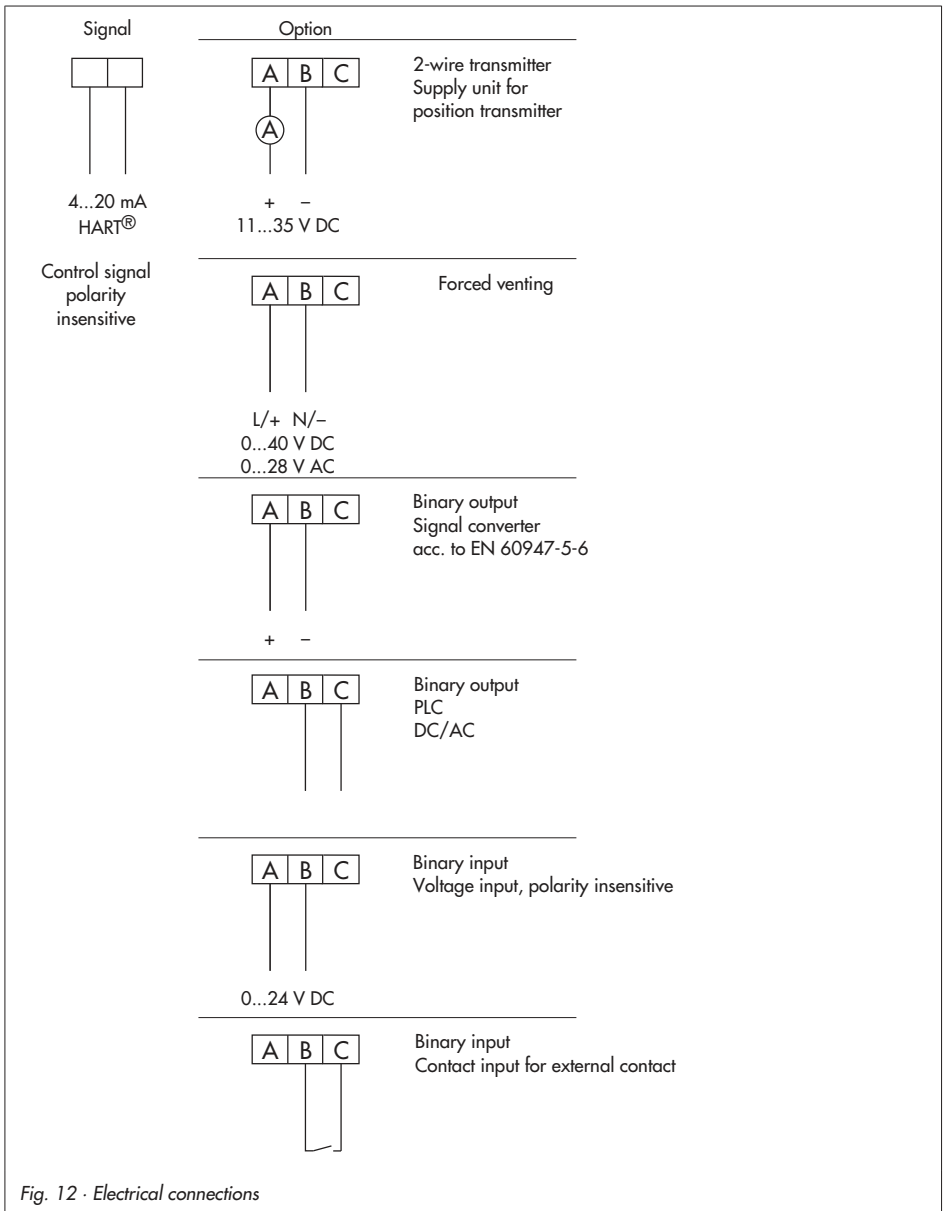

Fig. 12 · Electrical connections

5.2.1 Establishing communication

Communication between PC and the FSK modem or handheld communicator and positioner is based on the HART® protocol.

Type Viator FSK modem

RS-232	not ex	Order no. 8812-0130
USB	not ex	Order no. 8812-0132

If the load impedance of the controller or control station is too low, an isolation amplifier functioning as load converter is to be connected between controller and positioner.

Thanks to HART® protocol all control room and field devices connected in the loop are individually accessible through their address

via point-to-point or standard bus (Multidrop).

Point-to-point:

The bus address/polling address must always be set to zero (0).

Standard bus (Multidrop):

In the standard bus (Multidrop) mode, the positioner follows the analog current signal (reference variable) as for point-to-point communication. This operating mode is, for example, suitable for split-range operation of positioners (series connection). The bus address/polling address has to be within a range of 1 to 15.

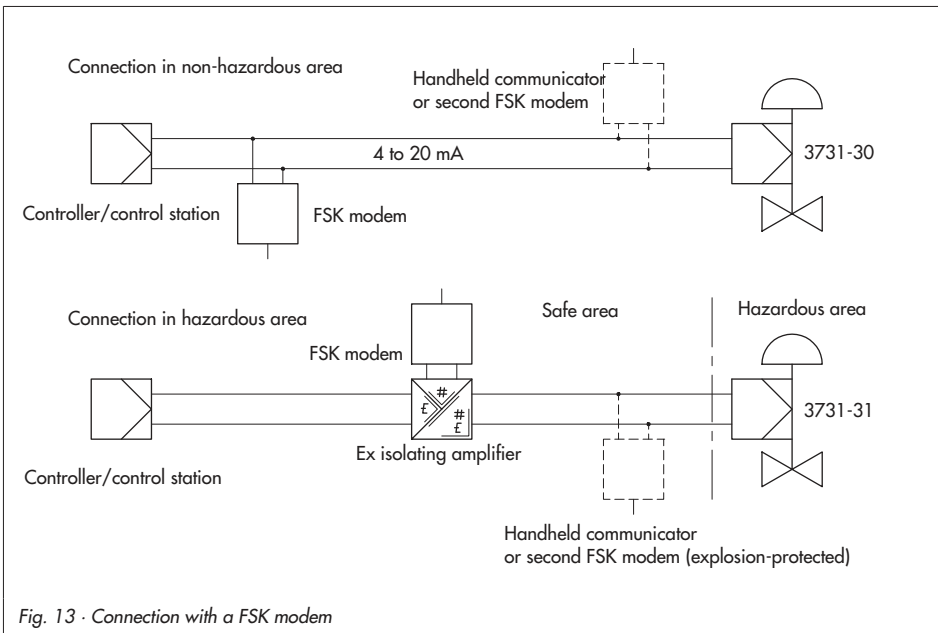

Fig. 13 · Connection with a FSK modem

Note:

Communication errors may occur when the process controller/control station output is not HART-compatible.

For adaptation, the Z box (order no. 1170-2374) can be installed between output and communication interface.

At the Z box a voltage of 330 mV is released (16.5 Ω at 20 mA).

Alternatively, a 250- Ω resistor can be connected in series and a 22- μ F capacitor can be connected in parallel to the analog output. Note that in this case, the controller output load will increase.

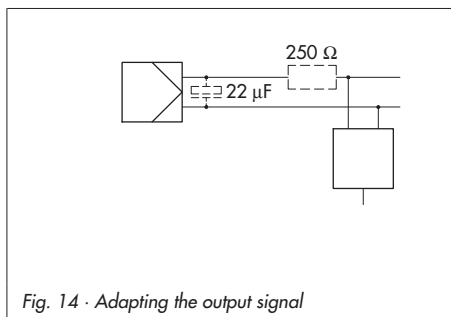

Fig. 14 · Adapting the output signal

6 Operator controls and readings

6.1 Rotary pushbutton

The rotary pushbutton (⊙) is located underneath the front protective cover.

The positioner is operated on site using the rotary pushbutton:

Turn ⊙ to select codes and values.

Press ⊙ to confirm setting.

6.2 Serial interface

The serial interface connection is located underneath the display lid: Unscrew and remove retaining screw and then unscrew display lid.

NOTICE

The explosion protection is ineffective as soon as the display lid is opened!



The positioner needs to be supplied with at least 4 mA.

To use the TROVIS-VIEW software, connect the positioner over an adapter (see accessories in Table 5) to the RS-232 or USB port of the computer.

6.3 Readings on display

Icons appear on the display that are assigned to parameters, codes and functions.

Operating modes:



▶  **Manual mode (MAN)**, section 8.2.1
The positioner follows the manual set point (Code 1) instead of the mA signal
 blinks: The positioner has not yet been initialized. Operation only possible over manual set point (Code 1).

▶  **Automatic mode (AUTO)**, section 8.2.1

The positioner is in closed-loop operation and follows the mA signal.

▶ **S Fail-safe position**, section 8.2.2
The positioner vents the output. The valve moves to the mechanical fail-safe position.

▶ **Bar elements:**

In  manual and  automatic modes, the bars indicate the system deviation that depends on the sign (+/-) and the value.

One bar element appears per 1 % system deviation.

If the device has not yet been initialized, the  icon blinks on the display and the lever position in degrees in relation to the longitudinal axis is indicated. One bar element corresponds to approximately a 5° angle of rotation.

If the fifth bar element blinks (reading > 30°), the permissible angle of rotation has been exceeded. Lever and pin position must be checked.

▶ **Status messages**

 : Maintenance alarm

 : Maintenance required/Maintenance demanded

 blinking: Out of specification

These icons indicate that an error has occurred.

A classified status can be assigned to

each error. Classifications include “No message”, “Maintenance required”, “Maintenance demanded”, “Out of specification” and “Maintenance alarm” (see section 8.3).

▶ **◇ Configuration enabled**

This indicates that the codes marked with an asterisk (*) in the code list (section 11) are enabled for configuration (see section 8.1).

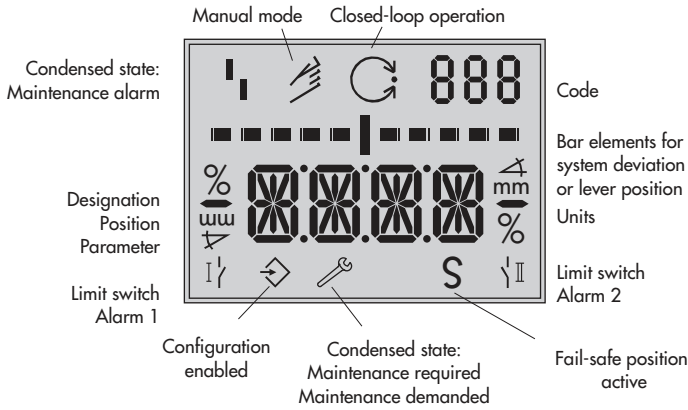

Readings and their meanings

AUTO	Automatic mode	NOM	Nominal travel	↗↗	Increasing/increasing
CL	Clockwise	OVERLOAD	w > 22 mA	↗↘	Increasing/decreasing
CCL	Counterclockwise	RES	Reset		
Err	Error	RUN	Start	⌚ blinking	Emergency mode, see Code 62
ESC	Escape	SAFE	Fail-safe position	✎ blinking	Not initialized
HI	ix greater than 21.6 mA	SUB	Substitute calibration	S blinking	Valve in mechanical fail-safe position
LO	ix smaller than 2.4 mA	TunE	Initialization in progress		
LOW	w lower than 3.7 mA	YES	Available/active		
MAN	Manual mode	ZP	Zero calibration		



Fig. 15 - Readings and operator controls

6.4 HART® communication

The positioner must be supplied with at least 3.8 mA current.

A DTM file (Device Type Manager) conforming to the Specification 1.2 is available for communication. This allows the device, for example, to be run with the PACTware operator interface. All the positioner's parameters are then accessible over the DTM and the operator interface.

Note: *In the case, complex functions are started in the positioner, which require a long calculation time or lead to a large quantity of data being stored in the volatile memory of the positioner, the alert "busy" is issued by the DTM file.*

This alert is not a fault alarm and can simply be confirmed.

Write protection

- ▶ The write protection for HART communication can be disabled over Code **47**. You can only disable or enable this function locally at the positioner. The write protection is enabled by default.
- ▶ The on-site operation can be locked over HART communication. **HART** then blinks on the display when Code **3** is selected. This locking function can only be disabled over HART communication. On-site operation is enabled by default.

6.4.1 Dynamic HART® variables

The HART® specification defines four dynamic variables consisting of a value and an engineering unit. These variables can be assigned to device parameters as required. The universal HART® command 3 (universal command #3) reads the dynamic variables out of the device. This allows manufacturer-specific parameters to also be transferred using a universal command.

The dynamic variables of Type 3731-3 can be assigned as follows in the DD or TROVIS-VIEW [Settings > Operation unit]:

Assignment of dynamic HART® variables		
Variable	Meaning	Unit
Set point		%
Direction of action set point		%
Set point after transit time specification		%
Valve position		%
Set point deviation e		%
Absolute total valve travel		–
Binary input status	0 = Not active 1 = Active 255 = –/–	–
Internal solenoid valve/forced venting status	0 = De-energized 1 = Energized 2 = Not installed	–
Condensed state	0 = No message 1 = Maintenance required 2 = Maintenance demanded 3 = Failure 4 = Out of specification 7 = Function check	–
Temperature		°C



7 Start-up – Settings

WARNING!

Attach the positioner, keeping the following sequence:

1. Mount the positioner on the control valve
2. Connect the supply air
3. Connect the electrical power
4. **Perform the start-up settings**

Reading on display after connecting the electrical auxiliary power:

- ▶ **iESinG** runs across the display and then  and  blink on the display when the positioner has **not yet been initialized**. The reading indicates the lever position in degrees in relation to the longitudinal axis.

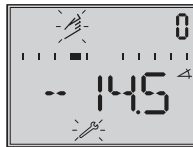

Reading when the positioner has not yet been initialized

- ▶ Code **0** appears on the display when a positioner has been **initialized**. The positioner is in the last active operating mode.

WARNING!

The actuator stem moves while the start-up settings are being performed.

Do not touch the actuator stem or obstruct it to avoid risk of injury to hands or fingers.

NOTICE

Perform the start-up settings in the same sequence as listed (section 7.1 to section 7.5).

7.1 Adapting the display

The reading on the display can be turned by 180° to adapt it to how the positioner is attached.



Reading direction for right attachment of pneumatic connections



Reading direction for left attachment of pneumatic connections

If the display appears upside down, proceed as follows:

Turn → Code 2

Press , Code 2 blinks.

Turn → Desired reading direction.

Press to confirm the reading direction.

7.2 Limiting the signal pressure

If the maximum actuator force may cause damage to the valve, the signal pressure must be limited.

NOTICE

Do not activate the pressure limit function in double-acting actuators (with fail-safe action AIR TO OPEN (A+O) (No = default)).

Enable configuration at the positioner before activating the pressure limit function:

Note: If no settings are entered within 120 seconds, the enabled configuration function becomes invalid.

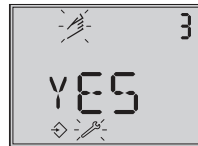

Configuration enabled
Default: No

Turn → Code 3, display: **No**

Press , Code 3 blinks

Turn → **YES**

Press , display

Pressure limit function:

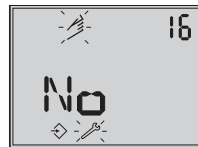

Pressure limit
Default: No

Turn → Code 16

Press , Code 16 blinks.

Turn until the required pressure limit (1.4/2.4/3.7 bar) appears.

Press to confirm the pressure limit setting.

7.3 Checking the operating range of the positioner

To check the mechanical attachment, the valve should be moved through the operating range of the positioner in the  manual mode using the manual reference variable w.

Select manual operating mode (MAN) :



Mode
Default: MAN

Turn  → Code **0**

Press , Code **0** blinks.

Turn  → **MAN**



Press  to change the positioner to manual mode.

Checking the operating range:



Manual reference variable
(the current opening angle
appears)

Turn  → Code **1**

Press , Code **1** and  icon blink.

Turn  until the pressure builds up in the positioner, and the control valve moves to its end positions to check the travel range/angle of rotation.

The angle of the lever on the back of the positioner is indicated on the display.

A horizontal lever (mid-position) is equal to 0°.

To ensure the positioner is working properly, the outer bar elements may not blink while the valve is moving through the operating range.

The manual mode can be exited by pressing the rotary pushbutton ().

The permissible range has been exceeded when the displayed angle is greater than 30°, and the outer right or left bar element blinks.

The positioner changes to the fail-safe position (SAFE).

After canceling the fail-safe position (SAFE) (see section 8.2.2) it is **absolutely necessary** to **check** the lever and pin position as described in section 4.

WARNING!

To avoid personal injury or property damage caused by the supply air or electrical auxiliary power, disconnect the supply air and electrical auxiliary power before exchanging the lever or changing the pin position.

7.4 Allocating the closed position

Taking into account the type of valve and the operating direction of the actuator, allocate the closed position (0 % travel):

- ▶ **AIR TO OPEN (A_rO)**
Signal pressure opens the valve.
Fail-close
- ▶ **AIR TO CLOSE (A_rC)**
Signal pressure closes the valve.
Fail-open

NOTICE

Double-acting actuators must always be set to **AIR TO OPEN (A_rO)**.

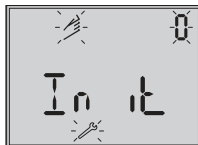

Initialization



AIR TO OPEN



AIR TO CLOSE

Turn → Code **0**

Press , display: **MAN**

Code **0** blinks.

Turn → **Init**

Press

Turn until the required closed position appears on the display.

Press to confirm the closed position.

Turn → **ESC**

Press to exit **or**:

Start initialization as described in section 7.5.

For checking purposes: After the positioner has been initialized successfully, the valve closed position is indicated on the positioner display as 0 %, whereas the valve open position is indicated by 100 %. If this is not the case, the closing direction has to be adapted correspondingly and the positioner needs to be re-initialized.

7.5 Positioner initialization

WARNING!

During initialization, the control valve moves through its entire travel/angle of rotation range. Therefore, do not start the initialization procedure while a process is running, but only during start-up when all shut-off valves are closed.

Before starting initialization, check the maximum permissible signal pressure of the control valve. During initialization, the positioner issues an output signal pressure up to the maximum supply pressure supplied. If necessary, limit the signal pressure by connecting an upstream pressure reducing valve.

NOTICE

If the positioner is mounted onto another actuator or its mounting position is changed, reset the positioner to its default settings before re-initializing it. Refer to section 7.7.

During initialization the positioner adapts itself optimally to the friction conditions and the signal pressure requirements of the control valve.

The type and extent of self-adaptation depends on the initialization mode selected:

- ▶ **MAX maximum range** (standard range)
Initialization mode for simple start-up of valves with two clearly defined mechanical end positions, e.g. three-way valves (see section 7.5.1)
- ▶ **NOM nominal range**
Initialization mode for all globe valves (see section 7.5.2)
- ▶ **MAN manually selected range**
Initialization mode for globe valves with an unknown nominal range (see section 7.5.3)
- ▶ **SUB substitute calibration** (emergency mode)
This mode allows a positioner to be replaced while the plant is running, with the least amount of disruption to the plant (see section 7.5.4)

Note: The initialization procedure can be interrupted while running by pressing the rotary pushbutton (⊙). **StOP** appears three seconds long and the positioner then changes to the fail-safe position (SAFE). The fail-safe position can be canceled again over Code **0** (see section 8.2.2).



Alternating displays:
Initialization running



Initialization progress indicated
(MAX, NOM, MAN or SUB appears, depending on the initialization mode selected)



Initialization successful
Positioner in  automatic mode

The time required for an initialization process depends on the stroking speed of the actuator and may take several minutes.

After a successful initialization, the positioner runs in automatic mode indicated by the  closed-loop control icon.

A malfunctioning leads to the process being interrupted. The initialization error appears on the display according to how it has been classified by the condensed state. See section 8.3 on page 60).

Note: The setting of Code **48 - h0 = YES** starts the plotting of the reference graphs required for valve diagnostics (drive signal steady-state **d1** and hysteresis **d2**) after initialization. **tESt** and **d1** and **d2** appear on the display in an alternating sequence.

An unsuccessful plotting of the reference graphs is indicated on the display by Code **48 - h1** and Code **81** (see error code list). The positioner still works properly, even though the reference graph plotting has not been completed successfully.

7.5.1 Initialization based on MAX maximum range

The positioner determines travel/angle of rotation of the closing member from the CLOSED position to the opposite side and adopts this travel/angle of rotation as the operating range from 0 to 100 %.

Enable configuration:

Note: If no settings are entered within 120 seconds, the enabled configuration function becomes invalid.



Configuration enabled
Default: No

Turn \odot → Code **3**, display: **No**

Press \odot , Code **3** blinks.

Turn \odot → **YES**

Press \odot , display: \Rightarrow

Select initialization mode:



Initialization mode
Default: MAX

Turn \odot → Code **6**

Press \odot

Turn \odot → **MAX**

Press \odot to confirm the **MAX** initialization mode.

Start initialization:

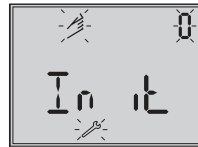

Initialization



Fail-safe position setting



Progress indicated until
initialization starts

Turn \odot → Code **0**

Press \odot , Code **0** blinks.

Turn \odot → **Init**

Press \odot . The setting of the fail-safe position **AtO** or **AtC** appears.

Keep \odot pressed down for 6 seconds.

Initialization starts after the progress indication has stopped.

The nominal travel/angle of rotation is indicated in % after initialization. Code **5** (nominal range) remains locked. The parameters for travel/angle range start (Code **8**) and travel/angle range end (Code **9**) can also only be displayed and modified in %.

For a reading in mm/°, enter the pin position (Code **4**).

Enter pin position:



Pin position
Default: No

Turn → Code **4**

Press , Code **4** blinks.

Turn → Pin position on lever (see relevant section on attachment).

Press . The reading of the nominal range appears in mm/°.

7.5.2 Initialization based on NOM nominal range

The calibrated sensor allows the effective valve travel to be set very accurately. During the initialization process, the positioner checks whether the control valve can move through the indicated nominal range (travel or angle) without collision.

If this is the case, the indicated nominal range is adopted with the limits of travel/angle range start (Code **8**) and travel/angle range end (Code **9**) as the operating range.

Note: The maximum possible travel must always be greater than the nominal travel entered. If this is not the case, initialization is interrupted (error message Code **52**) because the nominal travel is not achieved.

Enable configuration:

Note: If no settings are entered within 120 seconds, the enabled configuration function becomes invalid.



Configuration enabled
Default: No

Turn → Code **3**, display: **No**

Press , Code **3** blinks.

Turn → **YES**

Press , display:

Enter pin position and nominal travel:



Pin position
Default: No



Nominal range
(locked with Code **4** = No)

Turn → Code **4**

Press , Code **4** blinks.

Turn → Pin position on lever (see relevant section on attachment).

Press

Turn → Code **5**

Press , Code **5** blinks.

Turn → Nominal valve travel

Press **⊙**

Select initialization mode:



Initialization mode
Default: MAX

Turn **⊙** → Code **6**

Press **⊙**, Code **6** blinks.

Turn **⊙** → **NOM**

Press **⊙** to confirm the **NOM** initialization mode.

Start initialization:

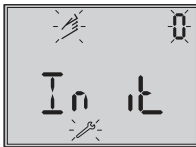

Initialization



Fail-safe position setting



Progress indicated until initialization starts

Turn **⊙** → Code **0**

Press **⊙**, Code **0** blinks.

Turn **⊙** → **Init**

Press **⊙**. The setting of the fail-safe position **Ato** or **Aic** appears.

Keep **⊙** pressed down for 6 seconds. Initialization starts after the progress indication has stopped.

Note: After initialization, check the direction of action and, if necessary, change it (Code 7).

7.5.3 Initialization based on MAN manually selected range

Before starting initialization, move the control valve manually to the OPEN position by turning **⊙** in small steps. The valve must move to the required valve position with a monotonically increasing signal pressure. The positioner calculates the differential travel/angle using the OPEN and CLOSED positions and adopts it as the operating range with limits of travel/angle range start (Code 8) and travel/angle range end (Code 9).

Enter OPEN position:



Manual reference variable (the current angle of rotation is displayed)

Turn **⊙** → Code **0**

Press **⊙**, Code **0** blinks.

Turn **⊙** → **MAN**

Press **⊙**

Turn **⊙** → Code **1**

Press **⊙**, Code **1** blinks.

Turn until the OPEN position of the valve is reached.

Press to confirm the OPEN position.

Enable configuration:

Note: If no settings are entered within 120 seconds, the enabled configuration function becomes invalid.

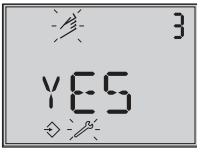

Configuration enabled
Default: No

Turn → Code **3**, display: **No**

Press , Code **3** blinks.

Turn → **YES**

Press , display:

Enter pin position:



Pin position
Default: No

Turn → Code **4**

Press , Code **4** blinks.

Turn → Pin position on lever (see relevant section on attachment).

Press

Select initialization mode:



Initialization mode
Default: MAX

Turn → Code **6**

Press , Code **6** blinks.

Turn → **MAN**

Press to confirm the **MAN** initialization mode.

Start initialization:

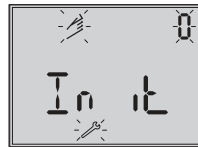

Initialization



Fail-safe position setting



Progress indicated until initialization starts

Turn → Code **0**

Press , Code **0** blinks.

Turn → **Init**

Press . The setting of the fail-safe position **AtO** or **AtC** appears.

Keep pressed down for 6 seconds.

Initialization starts after the progress indication has stopped.

7.5.4 SUB substitute calibration

A complete initialization procedure takes several minutes and requires the valve to move through its entire travel range several times. This initialization mode, however, is an emergency mode, in which the control parameters are estimated and not determined by an initialization procedure. As a result, a high level of accuracy cannot be expected. You should always select a different initialization mode if the plant allows it.

The **SUB** initialization mode is used to replace a positioner while the process is running. For this purpose, the control valve is usually fixed mechanically in a certain position, or pneumatically by means of a pressure signal which is routed to the actuator externally. The blocking position ensures that the plant continues to operate with this valve position.

By entering the blocking position (Code **35**), closing direction (Code **34**), pin position (Code **4**), nominal range (Code **5**) and direction of action (Code **7**), the positioner can calculate the positioner configuration.

NOTICE

Perform a reset before re-initializing the positioner if the substitute positioner has already been initialized. Refer to section 7.7.

Enable configuration:

Note: *If no settings are entered within 120 seconds, the enabled configuration function becomes invalid.*

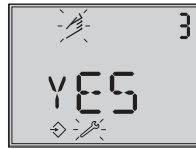

Configuration enabled
Default: No

Turn → Code **3**, display: **No**

Press , Code **3** blinks.

Turn → **YES**

Press , display:

Enter pin position and nominal travel:

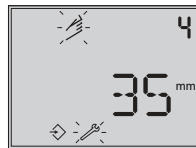

Pin position
Default: No



Nominal range
(locked with Code 4 = No)

Turn → Code **4**

Press , Code **4** blinks.

Turn → Pin position on lever (see relevant section on attachment).

Press .

Turn → Code **5**

Press , Code **5** blinks.

Turn → Nominal travel of the valve

Press

Select initialization mode:



Initialization mode
Default: MAX

Turn → Code 6

Press

Turn → **SUB**

Press to confirm the **SUB** initialization mode.

Enter direction of action:

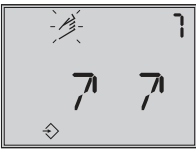

Direction of action
Default: ↗↗

Turn → Code 7

Press , Code 7 blinks.

Turn → Direction of action (↗↗/↘↘)

Press

Deactivate travel limit:

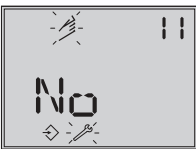

Travel limit
Default: 100.0

Turn → Code 11

Press , Code 11 blinks.

Turn → **No**

Press

Change pressure limit and control parameters:

Note: Do not change the pressure limit (Code 16). Only change the control parameters K_P (Code 17) and T_V (Code 18) if the settings of the replaced positioner are known.

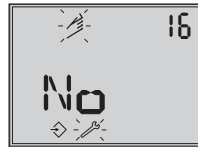

Pressure limit
Default: No

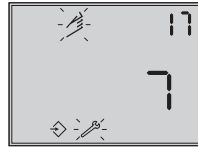

K_P stage
Default: 7

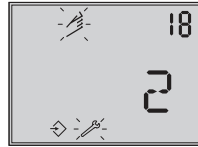

T_V stage
Default: 2

Turn → Code 16/17/18

Press , Code 16/17/18 blinks.

Turn and set the selected control parameter.

Press to confirm setting.

Enter closing direction and blocking position:



Closing direction
Direction of rotation causing the valve to move to the CLOSED position (view onto positioner display)
Default: CCL (counterclockwise)



Blocking position
Default: 0

Turn \odot → Code **34**

Press \odot , Code **34** blinks.

Turn \odot → Closing direction (CCL counter-clockwise/CL clockwise)

Press \odot

Turn \odot → Code **35**

Press \odot , Code **35** blinks.

Turn \odot → Blocking position, e.g. 5 mm (read off at travel indicator scale of the blocked valve or measure with a ruler).

Press \odot

Start initialization:

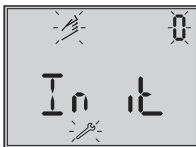

Initialization



Fail-safe position setting



Progress indicated until
initialization starts

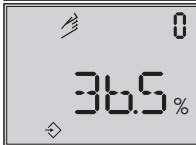

Blocking position

Turn \odot → Code **0**

Press \odot , Code **0** blinks.

Turn \odot → **Init**

Press \odot . The setting of the fail-safe position **Ato** or **Atc** appears.

Keep \odot pressed down for 6 seconds.

Initialization starts after the progress indication has stopped.

The operating mode changes to **MAN**.

The blocking position appears.

***Note:** As initialization has not been carried out completely, the error code **76** (no emergency mode) and possibly also error code **57** (control loop) may appear on the display.*

These messages do not influence the positioner's readiness for operation.

Cancel the blocking position and change to automatic mode \odot (AUTO):

For the positioner to follow its reference variable again, the blocking position must be canceled and the positioner must be set to automatic operating mode.

Turn \odot → Code **1**

Press \odot , Code **1** and the ⚡ icon blink.

Turn \odot until the pressure in the positioner builds up and the valve moves slightly past the blocking position.

Press \odot to cancel the blocking position.

Turn \odot → Code **0**

Press \odot , Code **0** blinks.

Turn \odot → **AUTO**

Press 

The positioner changes to automatic mode (AUTO). The current valve position is indicated in % on the display.

Note: If the positioner shows a tendency to hunt in automatic operating mode, the parameters K_p and T_V must be slightly corrected. Proceed as follows:

- Set T_V (Code **18**) to 4.
- Reduce K_p (Code **17**) until the positioner shows a stable behavior.

Zero point correction

Finally, if process operations allow it, the zero point must be calibrated as described in section 7.6.

7.6 Zero calibration

In case of discrepancies with the closing position of the valve, e.g. with soft-sealed plugs, it may become necessary to recalibrate the zero point.

NOTICE

The valve briefly moves from the current travel/angle of rotation position to the closed position.



Note: The positioner must be connected to the supply air to perform the zero calibration.

Enable configuration:

Turn  → Code **3**, display: **No**

Press , Code **3** blinks.

Turn  → **YES**

Press , display: 

Perform zero calibration:

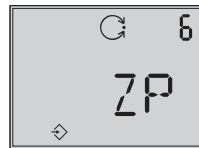

Initialization mode
Default: MAX

Turn  → Code **6**

Press , Code **6** blinks.

Turn  → **ZP**

Press 

Turn  → Code **0**

Press 

display: **MAN**, Code **0** blinks.

Turn  → **Init**

Press 

The setting of the fail-safe position **AtO** or **AtC** appears.

Keep  pressed down for 6 seconds.

Zero calibration is started, the positioner moves the control valve to the CLOSED position and recalibrates the internal electrical zero point.

7.7 Reset to default values



This function resets all start-up parameters and diagnosis data to their default values (see code list in section 11).

Enable configuration:

Turn  → Code **3**, display: **No**

Press , Code **3** blinks.

Turn  → **YES**

Press , display: 

Reset start-up parameters:



Reset
Default: No

Turn  → Code **36**, display: **••••-**

Press , Code **36** blinks.

Turn  → **Std**

Press . All start-up parameters and diagnosis data are reset to their default values.

Note: Code **36 - diAG** allows just the diagnosis data (EXPERTplus) to be reset. Refer to EB 8389 on EXPERTplus valve diagnostics.

8 Operation

WARNING!

The actuator stem moves while the positioner is being operated.

Do not touch the actuator stem or obstruct it to avoid risk of injury to hands or fingers.

8.1 Enabling and selecting parameters

All codes with their meanings and default settings are listed in the code list in section 11 on page 65 onwards.

The codes which are marked with an asterisk (*) must be enabled with Code 3 before the associated parameters can be configured as described below.

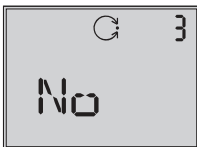

Code 3
Configuration
not enabled

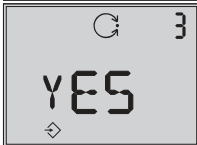

Configuration
enabled

Turn → Code 3, display: **No**

Press , Code 3 blinks.

Change the setting of Code 3.

Turn → **YES**

Turn , display:

The configuration is enabled.

You can now configure codes one after the other:

Turn and select the required code.

Press to access the selected code. The code number starts to blink.

Turn and select the setting.

Press to confirm the selected setting.

Note: If no settings are entered within 120 seconds, the enabled configuration function becomes invalid and the display changes to Code 0.

Canceling the setting



Canceling the setting

To cancel a value before it is confirmed (by pressing the rotary pushbutton) without the value you have just selected being adopted:

Turn → **ESC**

Press to confirm the cancelation.

The entry is ended without the value you have just selected being adopted.

8.2 Operating modes

8.2.1 Automatic (AUTO) and manual (MAN) modes

After initialization has been completed successfully, the positioner is in automatic mode  (AUTO).

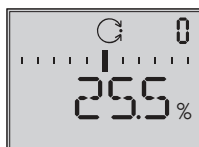

Automatic mode

Switching to manual mode (MAN)



Turn  → Code **0**

Press , display: **AUTO**, Code **0** blinks.

Turn  → **MAN**

Press  to switchover to manual mode. The switchover is smooth since the manual mode starts up with the set point last used during automatic mode. The current position is displayed in %.

Adjust the manual reference variable

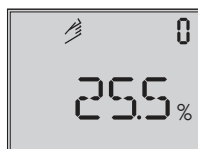

Turn  → Code **1**

Press , Code **1** blinks.

Turn  until sufficient pressure has been built up in the positioner and the control valve moves to the required position.

Note: If no settings are entered within approx. two minutes, the positioner automatically returns to Code **0**, but remains in manual mode.

Switching to automatic mode (AUTO):

Turn  → Code **0**

Press , Code **0** blinks.

Turn  → **AUTO**

Press  to switchover to automatic mode.

8.2.2 Fail-safe position (SAFE)

If you want to move the valve to fail-safe position determined during start-up (see section 7.4), proceed as follows:



Turn \odot → Code **0**

Press \odot , display: current operating mode (**AUTO** or **MAN**), Code **0** blinks.

Turn \odot → **SAFE**

Press \odot , display: **S**

The valve moves to the fail-safe position.

If the positioner is initialized, the current valve position is indicated on the display in %.

Exit the fail-safe position

Turn \odot → Code **0**

Press \odot , Code **0** blinks.

Turn \odot and select the required operating mode **AUTO** or **MAN**.

Press \odot

The positioner switches to the operating mode selected.

8.3 Malfunction/maintenance alarm

All status and fault alarms are assigned to a classified status in the positioner. The default settings of the status classification are listed in the code list.

Note: The status classification can be changed in TROVIS-VIEW and over the parameters in the DD file. Refer to EB 8389 on EXPERTplus valve diagnostics.

To provide a better overview, the classified messages are summarized in a condensed state. The following status messages are available:

▶ **Maintenance alarm**

The positioner cannot perform its control task due to a functional fault in the device or in one of its peripherals or an initialization has not yet been successfully completed.

▶ **Maintenance required**

The positioner still performs its control task (with restrictions). A maintenance requirement or above average wear has been determined. The wear tolerance will soon be exhausted or is reducing at a faster rate than expected. Maintenance is necessary in the medium term.

▶ **Maintenance demanded**

The positioner still performs its control task (with restrictions). A maintenance demand or above average wear has been determined. The wear tolerance will soon be exhausted or is reducing at a faster rate than expected. Maintenance is necessary in the short term.

► **Out of specification**

The positioner is operated outside specified operating conditions.

Note: *If an event is assigned to the “No message” status, this event does not have any effect on the condensed state.*

The condensed state is represented by the following icons on the positioner display:

Condensed state	Positioner display
Maintenance alarm	
Function check	Text e.g. <i>tESing, tunE</i> or <i>tESr</i>
Maintenance required/ Maintenance demanded	
Out of specification	

If the positioner has not been initialized, the maintenance alarm icon () appears on the display as the positioner cannot follow its reference variable.

If fault alarms exist, the possible source of error is displayed in Code **49** onwards. In this case, **Err** appears on the display.

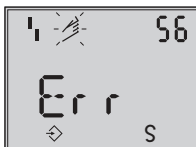

Example
Error caused by pin
position

The cause and recommended action are listed in the code list (section 11).

Fault alarm output

The “Maintenance alarm” as the condensed state causes the optional fault alarm output to be switched.

- The “Function check” condensed state can also switch the fault alarm contact in Code **32**.
- The “Maintenance required/demanded” condensed state can also switch the fault alarm contact in Code **33**.

8.3.1 Confirming error messages

Enable configuration:

Turn → Code **3**, display: **No**

Press , Code **3** blinks.

Turn → **YES**

Press , display:

Confirming error message:

Turn → Select error code which you want to confirm.

Press .

The error message is confirmed.

9 Maintenance

The positioner does not require any maintenance.

There are filters with a 100 µm mesh size in the pneumatic connections for supply and output which can be removed and cleaned, if required.

The maintenance instructions of any upstream supply air pressure reducing stations must be observed.

10 Servicing explosion-protected devices

If a part of the positioner on which the explosion protection is based needs to be serviced, the positioner must not be put back into operation until an expert has inspected the device according to explosion protection requirements, has issued a certificate stating this or given the device a mark of conformity.

Inspection by an expert is not required if the manufacturer performs a routine test on the device prior to putting it back into operation. The passing of the routine test must be documented by attaching a mark of conformity to the device.

11 Code list

Code no.	Parameter – Display, values [default setting]	Description
Note: Codes with marked with an asterisk (*) must be enabled with Code 3 prior to configuration.		
0	Operating mode [MAN] AUtO · SAFE ESC Init · AtO · AtC	<p>AUtO Automatic mode MAN Manual mode SAFE Fail-safe position ESC Escape</p> <p>In MAN and AUtO mode, the system deviation is represented by bar elements on the display.</p> <p>If the positioner has been initialized, the numerical reading indicates the valve position or the angle of rotation in %, otherwise the position of the lever in relation to the central axis is displayed in degrees °.</p> <p>Switchover from automatic to manual mode is smooth.</p> <p>In fail-safe position, the S icon appears on the display.</p> <p>Init Start initialization Allocate closed position: AtO: AIR TO OPEN (valve CLOSED in fail-safe position) or AtC: AIR TO CLOSE (valve OPEN in fail-safe position)</p>
1	Manual reference variable w [0] to 100 % of the nominal range	<p>Setting the manual reference variable w</p> <p>The current travel/angle is displayed in % when the positioner has been initialized, otherwise the position of the lever in relation to the central axis is indicated in degrees °.</p> <p>Can only be selected when Code 0 = MAN.</p>
2	Reading direction [Normal] or upside down ESC	The reading direction of the display is turned by 180°.
3	Enable configuration [No] YES ESC	<p>Enables the option to modify data (automatically deactivated when the rotary pushbutton has not been operated for 120 s.)</p> <p>HART blinks on the display when the on-site operation is locked over HART® communication.</p> <p>Codes marked with an asterisk (*) can only be read and not overwritten.</p> <p>Codes can also only be read over the SSP interface.</p>

Code no.	Parameter – Display, values [default setting]	Description																											
Note: Codes with marked with an asterisk (*) must be enabled with Code 3 prior to configuration.																													
4*	Pin position [No] 17, 25, 35, 50, 70, 100, 200 mm 90° with rotary actuators ESC <i>Note: If you select a pin position in Code 4 that is too small, the positioner switches to the fail-safe position mode (SAFE) for reasons of safety.</i>	<p>The follower pin must be inserted into the correct pin position according to the valve travel/angle of rotation.</p> <p>The pin position must be entered for initialization using NOM or SUB.</p> <table border="1"> <thead> <tr> <th>Pin position Code 4</th> <th>Standard Code 5</th> <th>Adjustment range Code 5</th> </tr> </thead> <tbody> <tr> <td>17</td> <td>7.5</td> <td>3.6 to 18.0</td> </tr> <tr> <td>25</td> <td>7.5</td> <td>5.0 to 25.0</td> </tr> <tr> <td>35</td> <td>15.0</td> <td>7.0 to 35.0</td> </tr> <tr> <td>50</td> <td>30.0</td> <td>10.0 to 50.0</td> </tr> <tr> <td>70</td> <td>40.0</td> <td>14.0 to 70.7</td> </tr> <tr> <td>100</td> <td>60.0</td> <td>20.0 to 100.0</td> </tr> <tr> <td>200</td> <td>120.0</td> <td>40.0 to 200.0</td> </tr> <tr> <td>90°</td> <td>90.0</td> <td>24.0 to 100.0</td> </tr> </tbody> </table>	Pin position Code 4	Standard Code 5	Adjustment range Code 5	17	7.5	3.6 to 18.0	25	7.5	5.0 to 25.0	35	15.0	7.0 to 35.0	50	30.0	10.0 to 50.0	70	40.0	14.0 to 70.7	100	60.0	20.0 to 100.0	200	120.0	40.0 to 200.0	90°	90.0	24.0 to 100.0
Pin position Code 4	Standard Code 5	Adjustment range Code 5																											
17	7.5	3.6 to 18.0																											
25	7.5	5.0 to 25.0																											
35	15.0	7.0 to 35.0																											
50	30.0	10.0 to 50.0																											
70	40.0	14.0 to 70.7																											
100	60.0	20.0 to 100.0																											
200	120.0	40.0 to 200.0																											
90°	90.0	24.0 to 100.0																											
5*	Nominal range mm or angle ° ESC	<p>For initialization using NOM or SUB, the nominal travel/angle of rotation of the valve must be entered.</p> <p>The permissible adjustment range depends on the pin position according to the table for Code 4.</p> <p>Code 5 is generally locked until Code 4 is set to No, i.e. after a pin position has been entered, Code 5 can be configured.</p> <p>After initialization has been successfully completed, the maximum nominal travel/angle reached on initialization is displayed.</p>																											
6*	Initialization mode [MAX] NOM · MAN · SUB · ZP ESC	<p>Select the initialization mode</p> <p>MAX: Maximum range of the control valve, the travel/angle of the closure member from the CLOSED position to the opposite stop in the actuator.</p> <p>NOM: Nominal range of the control valve, the travel/angle of the closure member measured from the CLOSED position to the indicated OPEN position.</p> <p>MAN: Manually selected range</p> <p>SUB: Substitute calibration (without initialization)</p> <p>ZP: Zero calibration</p>																											

Code no.	Parameter – Display, values [default setting]	Description
Note: Codes with marked with an asterisk (*) must be enabled with Code 3 prior to configuration.		
7*	Direction of action w/x [↗↗] ↗↘ ESC	<p>Direction of action of the reference variable w in relation to the travel/angle of rotation x (increasing/increasing or increasing/decreasing).</p> <p>Automatic adaptation:</p> <p>AIR TO OPEN: After initialization, the direction of action remains increasing/increasing (↗↗), a globe valve opens as the reference variable increases.</p> <p>AIR TO CLOSE: After initialization, the direction of action changes to increasing/decreasing (↗↘), a globe valve closes as the reference variable increases.</p>
8*	Travel/angle range start (lower x-range value) 0.0 to 80.0 [0.0] % of the nominal range Specified in mm or angle ° provided Code 4 is set ESC	<p>Starting value for the travel/angle of rotation in the nominal or operating range.</p> <p>The operating range is the actual travel/angle of the control valve and is limited by the travel/angle range start (Code 8) and the travel/angle range end (Code 9).</p> <p>Usually, the operating range and the nominal range are identical. The nominal range can be limited to the operating range by the travel/angle range start and end. Value is displayed or must be entered.</p> <p>The characteristic is adapted.</p> <p>See also the example in Code 9.</p>
9*	Travel/angle range end (upper x-range value) 20.0 to 100.0 [100.0] % of the nominal range Specified in mm or angle ° provided Code 4 is set ESC	<p>End value for the travel/angle of rotation in the nominal or operating range. Value is displayed or must be entered.</p> <p>The characteristic is adapted.</p> <p>Example: The operating range is modified, for example, to limit the range of a control valve which has been sized too large. For this function, the entire resolution range of the reference variable is converted to the new limits. 0 % on the display corresponds to the adjusted lower limit and 100 % to the adjusted upper limit.</p>
10*	Travel/angle lower limit (lower x-limit) [No] 0.0 to 49.9 % of the operating range ESC	<p>Limitation of the travel/angle of rotation downwards to the entered value.</p> <p>The characteristic is not adapted.</p> <p>See also example in Code 11.</p>

Code no.	Parameter – Display, values [default setting]	Description
Note: Codes with marked with an asterisk (*) must be enabled with Code 3 prior to configuration.		
11*	Travel/angle upper limit (upper x-limit) 50.0 to 120.0 [100] % of the operating range No · ESC	<p>Limitation of the travel/angle of rotation upwards to the entered value.</p> <p>When set to No, the valve can be opened past the nominal travel with a reference variable outside of the 0 to 100 % range. The characteristic is not adapted.</p> <p>Example: In some applications, it is better to limit the valve travel, e.g. if a certain minimum medium flow is required or a maximum flow must not be reached. The lower limit must be adjusted with Code 10, and the upper limit with Code 11.</p> <p>If a tight-closing function has been set up, it has priority over the travel limitation.</p>
12*	Reference variable range start (w-start) 0.0 to 75.0 % of the reference variable range [0.0 %] ESC	<p>Lower range value of the applicable reference variable range must be smaller than the final value w-end, 0 % = 4 mA. The reference variable range is the difference between w-end and w-start, and must be $\Delta w \geq 25 \% = 4 \text{ mA}$.</p> <p>For an adjusted reference variable range of 0 to 100 % = 4 to 20 mA, the control valve must move through its entire operating range from 0 to 100 % travel/angle of rotation.</p> <p>In split-range operation, the valves operate with smaller reference variables. The control signal of the control unit to control two valves is divided such, for instance, that the valves move through their full travel/angle of rotation at only half the input signal (first valve set to 0 to 50 % = 4 to 12 mA and the second valve set to 50 to 100 % = 12 to 20 mA reference variable).</p>
13*	Reference variable range end (w-end) 25.0 to 100.0 % of the reference variable range [100.0 %] ESC	<p>Upper range value of the applicable reference variable range, must be greater than w-start.</p> <p>100 % = 20 mA</p>

Code no.	Parameter – Display, values [default setting]	Description
Note: Codes with marked with an asterisk (*) must be enabled with Code 3 prior to configuration.		
14*	Setpoint cutoff decrease (final position w <) 0.0 to 49.9 [1.0] % No · ESC	If reference variable w reaches the percentage adjusted that causes the valve to close, the actuator is immediately completely vented (with AIR TO OPEN) or filled with air (with AIR TO CLOSE). This action always lead to maximum tight-closing of the valve. Codes 14/15 have priority over Codes 8/9/10/11. Codes 21/22 have priority over Codes 14/15.
15*	Setpoint cutoff increase (final position w >) [No] 50.0 to 100.0 % ESC	If reference variable w reaches the percentage adjusted that causes the valve to open, the actuator is immediately completely filled with air (with AIR TO OPEN) or vented (with AIR TO CLOSE). This action always lead to the valve being completely opened. A signal pressure limit is possible over Code 16. Codes 14/15 have priority over Codes 8/9/10/11. Codes 21/22 have priority over Codes 14/15. Example: Set the cutoff to 99 % for three-way valves.
16*	Pressure limit [No] P 1.4 · 2.4 · 3.7 ESC	The signal pressure to the actuator can be limited in stages. After changing a pressure limit already set, the actuator must be vented once (e.g. by selecting the fail-safe position (SAFE) over Code 0). NOTICE <i>Do not activate the pressure limit for double-acting actuators with fail-safe position AIR TO OPEN (Ato).</i>
17*	Proportional-action coefficient KP (step) 0 to 17 [7] ESC	Displaying or changing the K_p and T_v steps: During initialization, the K _p and T _v values are optimized. Should the positioner show a tendency for impermissibly high post-pulse oscillation due to additional interference, the K _p and T _v steps can be adapted after initialization. For this, either the T _v step can be increased in increments until the desired response behavior is reached or, when the maximum value of 4 is reached, the K _p step can be decreased in increments. Note: <i>Changing the K_p step influences the system deviation.</i>
18*	Rate time TV (step) [2] 1 3 4 No ESC	Changing T _v , see Code 17. Note: <i>Changing the T_v step has no effect on the system deviation.</i>

Code no.	Parameter – Display, values [default setting]	Description
Note: Codes with marked with an asterisk (*) must be enabled with Code 3 prior to configuration.		
19*	Tolerance band 0.1 to 10.0 [5] % of the operating range ESC	Used for error monitoring Determination of the tolerance band in relation to the operating range. Associated lag time [30] s is a reset criterion. If a lag time is determined during initialization which is six times > 30 s, the six-fold lag time is accepted as the lag time.
20*	Characteristic 0 to 9 [0] ESC	Select the characteristic: 0 Linear 1 Equal percentage 2 Reverse equal percentage 3 SAMSON butterfly valve linear 4 SAMSON butterfly valve equal percentage 5 VETEC rotary plug valve linear 6 VETEC rotary plug valve equal percentage 7 Segmented ball valve linear 8 Segmented ball valve equal percentage 9 User-defined (defined over operating software) Note: The various characteristics are listed in the Appendix (section 13.1).
21*	Required transit time OPEN (w ramp open) 0 to 240 s [0] ESC	The time required to pass through the operating range when the valve opens. Limitation of the transit time (Code 21 and 22): For some applications it is better to limit the actuating speed of the actuator to prevent it from engaging too fast in the running process. Code 21 has priority over Code 15.
22*	Required transit time CLOSED (w ramp closed) 0 to 240 s [0] ESC	The time required to pass through the operating range when the valve closes. Code 22 has priority over Code 14.
23*	Total valve travel 0 to $99 \cdot 10^7$ [0] Exponential reading from 9999 travel cycles onwards RES · ESC	Totaled double valve travel. Can be reset to 0 via RES. Note: The number of travel cycles (in steps of 1000) is saved in a non-volatile memory.



Code no.	Parameter – Display, values [default setting]	Description												
Note: Codes with marked with an asterisk (*) must be enabled with Code 3 prior to configuration.														
24*	Limit of total valve travel 1000 to 99 · 10 ⁷ [1 000 000] Exponential reading from 9999 travel cycles onwards ESC	Limit value of total valve travel. If the limit is exceeded, the fault alarm and the wrench icons appear on the display.												
25*	Binary output [A1 - / -] ESC	<p>This code allows you to find out on site whether the positioner has an optional binary output or not. When a binary output exists, its switching performance can be read and set. If there is no binary output, - - - - appears on the display of the positioner.</p> <p>The binary contacts A1, A2 and the fault alarm output can be configured at the output as follows:</p> <table border="1"> <thead> <tr> <th>Alternating display</th> <th>Meaning</th> </tr> </thead> <tbody> <tr> <td>A1 - / -</td> <td>A1 functioning as NO contact</td> </tr> <tr> <td>A1 ----</td> <td>A1 functioning as NC contact</td> </tr> <tr> <td>A2 - / -</td> <td>A2 functioning as NO contact</td> </tr> <tr> <td>A2 ----</td> <td>A2 functioning as NC contact</td> </tr> <tr> <td>FAUL FAUL</td> <td>Fault alarm output (always NC contact)</td> </tr> </tbody> </table>	Alternating display	Meaning	A1 - / -	A1 functioning as NO contact	A1 ----	A1 functioning as NC contact	A2 - / -	A2 functioning as NO contact	A2 ----	A2 functioning as NC contact	FAUL FAUL	Fault alarm output (always NC contact)
Alternating display	Meaning													
A1 - / -	A1 functioning as NO contact													
A1 ----	A1 functioning as NC contact													
A2 - / -	A2 functioning as NO contact													
A2 ----	A2 functioning as NC contact													
FAUL FAUL	Fault alarm output (always NC contact)													
26*	Limit value A1 No 0.0 to 100.0 [2.0] % of the operating range ESC	Displaying or changing the software limit value A1 in relation to the operating range.												
27*	Limit value A2 No 0.0 to 100.0 [98.0] % of the operating range ESC	Displaying or changing the software limit value A2 in relation to the operating range.												

Code no.	Parameter – Display, values [default setting]	Description
Note: Codes with marked with an asterisk (*) must be enabled with Code 3 prior to configuration.		
28*	Alarm test Reading direction: Standard Turned [No] [No] RUN 1 1 RUN RUN 2 2 RUN RUN 3 3 RUN ESC ESC	Testing the software limit switches alarm A1 and A2 as well as the fault alarm contact A3. If the test is activated, the respective limit switches five times. RUN1/1 RUN: Software limit switch A1 RUN2/2 RUN: Software limit switch A2 RUN3/3 RUN: Fault alarm contact A3
29*	Position transmitter x/ix ³⁾ [↗↘] ↗↘ ESC	Operating direction of the position transmitter; indicates how the travel/angle position is assigned to the output signal i, based on the closed position. The operating range (see Code 8) of the valve is represented by the 4 to 20 mA signal. When a positioner is not connected (reference variable less than 3.6 mA), the signal is 0.9 mA and when the positioner has not been initialized 3.8 mA.
30*	Fault alarm ix ³⁾ [No] HI LO ESC	Used to select whether faults causing the fault alarm contact to switch should also be signaled by the position transmitter output and how they should be signaled HI ix = 21.6 mA or LO ix = 2.4 mA
31*	Position transmitter test ³⁾ -10.0 to 110.0 [default value is the last indicated value of the position transmitter] % of the operating range ESC	Testing the position transmitter. Values can be entered in relation to the operating range. The current actual value is used in initialized positioners locally as the start value (bumpless changeover to the test mode). On testing over software, the entered simulation value is issued as the position feedback signal for 30 seconds.
³⁾ Analog position transmitter: Code 29/30/31 can only be selected if the position transmitter (optional) is installed.		

Code no.	Parameter – Display, values [default setting]	Description
Note: Codes with marked with an asterisk (*) must be enabled with Code 3 prior to configuration.		
32*	“Function check” alarm No · [YES] ESC	The condensed state can be used for a fault alarm output over the optional binary contact and the optional position transmitter (see Code 25). No “Function check” condensed state has no affect on the fault alarm output YES “Function check” condensed state switches the fault alarm output
33*	“Maintenance required” alarm No · [YES] ESC	No Only the “Maintenance alarm” condensed state switches the fault alarm output, “Maintenance required”/“Maintenance demanded”, however, does not YES Both the “Maintenance alarm” condensed state and “Maintenance required”/“Maintenance demanded” condensed state switch the fault alarm output
34*	Closing direction [CCL] Counterclockwise CL Clockwise ESC	Turning direction of the lever in which the valve is moved to the CLOSED position (view onto the display of the positioner). Needs only be entered in SUB initialization mode.
35*	Blocking position [0] mm/° /% ESC	Distance up to the CLOSED position (0 % position). Only needs to be entered in SUB initialization mode.
36*	Reset [No] Std · diAG ESC	Std: Resets all parameters to default (factory setting) as well as the diagnosis data. After a reset, the positioner must be re-initialized. diAG: Resets diagnosis data only. Plotted reference graphs and logs remain unaffected. The positioner does not need to be re-initialized.
37*	Position transmitter [No] YES ESC	Display only, indicates whether the position transmitter option is installed.
38*	Inductive alarm No	Type 3731-3 does not have an optional inductive alarm.
39	System deviation e -99.9 to 999.9 %	Deviation from the target position ($e = w - x$) Display only

Code no.	Parameter – Display, values [default setting]	Description
Note: Codes with marked with an asterisk (*) must be enabled with Code 3 prior to configuration.		
40	Minimum transit time OPEN 0 to 240 s [0 s]	Time [s] needed by the system (positioner, actuator and valve) to move through the nominal travel/angle to open the valve (100 % position). Display only
41	Minimum transit time CLOSED 0 to 240 s [0 s]	Time [s] needed by the system (positioner, actuator and valve) to move through the nominal travel/angle to close the valve (0 % position). Display only
42	Auto-w/manual-w 0.0 to 100.0 % of the span 4 to 20 mA	Supplied manual and automatic reference variable Display only
43	Firmware version control Xxxx	Positioner type and current firmware version (in alternating sequence) Display only
44	y info 0 to 100 %, [0 %]	Control signal y [%] based on the travel range determined on initialization · Display only MAX: The positioner builds up its maximum output pressure, see description in Code 14 and 15 . 0 P: The positioner vents completely, see description in Code 14 and 15 . ---: The positioner has not been initialized.
45	Forced venting status No · HIGH/LOW · YES	Indicates whether the option is installed or not · Display only No No forced venting installed YES Forced venting installed If a voltage supply is connected at the terminals of the optional forced venting, YES and HIGH appear on the display in alternating sequence. If a voltage supply is not applied (actuator vented, fail-safe position indicated on the display by the S icon), YES and LOW appear on the display in alternating sequence.
46*	Polling address 0 to 15/63 [0] ESC	Select bus address 0 to 15 for active HART® Revision 5 (default setting) 0 to 63 for active HART® Revision 6. The address can only be switched over using the operating software.

Code no.	Parameter – Display, values [default setting]	Description
Note: Codes with marked with an asterisk (*) must be enabled with Code 3 prior to configuration.		
47*	Write protection HART [No] · YES ESC	When the write protection function is activated, device data can only be read, but not overwritten over HART® communication.
48* 49*	Diagnostics Refer to EB 8389 on EXPERTplus Valve Diagnostics	

Note: The error codes listed in following appear in the display corresponding to their status classification set over the condensed state (Maintenance required/Maintenance demanded: , Out of specification:  blinking, Maintenance alarm: ). If "No message" is assigned to the error code as the status classification, the error is not included in the condensed state. A status classification is assigned to every error code in the default setting. The status classification of error codes can also be changed as required using an operating software (e.g. TROVIS-VIEW).

Initialization errors

Error codes – Recommended action		Condensed state message active, when prompted, <i>Err</i> appears. When fault alarms exist, they are displayed here.
50	x > range	<p>The value supplied by the measuring signal is either too high or too low, the measuring sensor is close to its mechanical limit.</p> <ul style="list-style-type: none"> • Pin positioned incorrectly. • Bracket slipped in case of NAMUR attachment or positioner is not central. • Follower plate incorrectly attached.
	Status classification	[Maintenance required]
	Recommended action	Check attachment and pin position, set operating mode from SAFE to MAN and re-initialize the positioner.
51	$\Delta x < \text{range}$	<p>The measuring span of the sensor is too low.</p> <ul style="list-style-type: none"> • Pin positioned incorrectly. • Wrong lever. <p>A rotational angle smaller than 16° at the positioner shaft creates just an error message. An angle below 9° leads to the initialization being canceled.</p>
	Status classification	[Maintenance required]
	Recommended action	Check attachment and re-initialize the positioner.
52	Attachment	<ul style="list-style-type: none"> • Positioner attachment incorrect. • Nominal travel/angle (Code 5) could not be achieved during initialization under NOM (no tolerance downwards permissible). • Mechanical or pneumatic fault, e.g. wrong lever selected or supply pressure too low to move to the required position.
	Status classification	[Maintenance required]
	Recommended action	<p>Check attachment and supply pressure. Re-initialize the positioner.</p> <p>Under certain circumstances, it may be possible to check the maximum travel/angle by entering the actual pin position and then performing an initialization under MAX.</p> <p>After initialization has been completed, the Code 5 indicates the maximum achieved travel or angle.</p>

Error codes – Recommended action		Condensed state message active, when prompted, Err appears. When fault alarms exist, they are displayed here.
53	Initialization time exceeded (Init time >)	The initialization routine lasts too long. <ul style="list-style-type: none"> • No pressure on the supply line or there is a leak. • Supply air failure during initialization.
	Status classification	[Maintenance required]
	Recommended action	Check attachment and supply pressure. Re-initialize the positioner.
54	Initialization/forced venting	1) A solenoid valve is installed (Code 45 = YES) and was not or not properly connected so that an actuator pressure could not be built up. The message is generated when you attempt to initialize the positioner. 2) If you attempt to initialize the device from the fail-safe position (SAFE).
	Status classification	[Maintenance required]
	Recommended action	Re. 1) Check connection and supply voltage of the forced venting Code 45 HIGH/LOW Re. 2) Set the MAN operating mode over Code 0 . Then initialize the positioner.
55	Transit time too short (transit time <)	The actuator positioning rates determined during the initialization are so short that the positioner cannot adapt itself optimally.
	Status classification	[Maintenance required]
	Recommended action	Check the volume restriction setting as described in section 4, re-initialize the positioner.
56	Pin position	Initialization was canceled because you are required to enter the pin position for the selected initialization modes NOM and SUB .
	Status classification	[Maintenance required]
	Recommended action	Enter pin position over Code 4 and nominal travel/angle over Code 5 . Re-initialize the positioner.

Operational errors

Error codes – Recommended action		Condensed state message active, when prompted, Err appears. When fault alarms exist, they are displayed here.
57	Control loop	Control loop error, the control valve does not react within the tolerable times of the controlled variable (tolerance band alarm Code 19).
	Additional alarm at the fault alarm output	<ul style="list-style-type: none"> • Actuator mechanically blocked. • Attachment of the positioner subsequently shifted. • Supply pressure not sufficient.
	Status classification	[Maintenance required]
	Recommended action	Check attachment.
58	Zero point	Zero point incorrect. Error may arise when the mounting position/linkage of the positioner moves or when the valve seat trim is worn, especially with soft-sealed plugs.
	Status classification	[Maintenance required]
	Recommended action	Check valve and mounting of the positioner. If OK, perform a zero calibration over Code 6 (see section 7.6 on page 58). If the lever position on the back of the positioner has been changed (e.g. while exchanging the lever), move the lever as far as it will go in both directions to adapt it to the internal measuring lever. We recommend re-initializing the positioner if the zero point deviates by more than 5 %.
59	Autocorrection	Should an error occur in the data range of the positioner, the self-monitoring function recognizes it and automatically corrects it.
	Status classification	[No message]
	Recommended action	Automatic
60	Fatal error	An error was detected in the data relevant for safety, autocorrection is not possible. This may be due to EMC disturbances. The positioner changes to the fail-safe position (SAFE).
	Status classification	Maintenance alarm (cannot be classified)
	Recommended action	Reset over Code 36 . Re-initialize the positioner (see sections 7.7 and 7.5).

Hardware errors

Error codes – Recommended action		Condensed state message active, when prompted, Err appears. When fault alarms exist, they are displayed here.
62	x signal Additional alarm at the fault alarm output	<p>Determination of the measured data for the actuator has failed. Conductive plastic element is defective. The positioner continues to run in emergency mode, but should be replaced as soon as possible. The emergency mode on the display is indicated by a blinking closed-loop control icon and 4 dashes instead of the position indication.</p> <p>Note on the control: If the measuring system has failed, the positioner is still in a reliable state. The positioner switches to emergency mode where the position cannot be accurately controlled anymore. However, the positioner continues operation according to its reference variable signal so that the process remains in a safe state.</p>
	Status classification	[Maintenance required]
	Recommended action	Return the positioner to SAMSON AG for repair.
63	w too low	<p>The reference variable w is lower than 3.7 mA. This message occurs whenever the power source that drives the positioner does not comply with the standard. This condition is indicated on the positioner display by LOW blinking. The positioner changes to the fail-safe position (SAFE).</p>
	Status classification	[No message]
	Recommended action	Check the reference variable. If necessary, limit the current source downwards so that no values below 3.7 mA can be issued.
64	i/p converter	<p>The circuit of the i/p converter has been interrupted. The positioner changes to the fail-safe position (SAFE).</p>
	Status classification	Maintenance alarm (cannot be classified)
	Recommended action	Cannot be remedied. Return the positioner to SAMSON AG for repair.

Error codes – Recommended action		Condensed state message active, when prompted, Err appears. When fault alarms exist, they are displayed here.
65	Hardware Additional alarm at the fault alarm output	Initialization key jammed (firmware version 1.51 and higher) A hardware error has occurred, the positioner changes to the fail-safe position (SAFE).
	Status classification	Maintenance alarm (cannot be classified)
	Recommended action	Confirm error and return to the automatic operating mode, or perform a reset and re-initialize the device. If this is not successful, return device to SAMSON AG for repair.
66	Data memory Additional alarm at the fault alarm output	The writing of data to the data memory does not work anymore, e.g. when the written data deviate from the read data. Valve moves to the fail-safe position.
	Status classification	Maintenance alarm (cannot be classified)
	Recommended action	Return the positioner to SAMSON AG for repair.
67	Test calculation Additional alarm at the fault alarm output	The hardware controller is monitored by means of a test calculation.
	Status classification	Maintenance alarm (cannot be classified)
	Recommended action	Confirm error. If this is not possible, return the positioner to SAMSON AG for repair.

Data errors

Error codes – Recommended action		Condensed state message active, when prompted, Err appears. When fault alarms exist, they are displayed here.
68	Control parameter Additional alarm at the fault alarm output	Control parameter error
	Status classification	[Maintenance required]
	Recommended action	Confirm error, perform reset and re-initialize the positioner.
69	Poti parameter Additional alarm at the fault alarm output	Parameter error of the digital potentiometer.
	Status classification	[Maintenance required]
	Recommended action	Confirm error, perform reset and re-initialize the positioner.
70	Calibration parameter Additional alarm at the fault alarm output	Error in the production calibration data. Subsequently, the device runs on default values.
	Status classification	[Maintenance required]
	Recommended action	Return the positioner to SAMSON AG for repair.
71	General parameters	Parameter errors that are not critical for the control.
	Status classification	[Maintenance required]
	Recommended action	Confirm error. Check and, if necessary, reset required parameters.
72	Start-up parameters	Start-up parameter error
	Status classification	[Maintenance required]
	Recommended action	Confirm error, perform reset and re-initialize the positioner.
73	Internal device error 1	Internal device error
	Status classification	[Maintenance required]
	Recommended action	Return the positioner to SAMSON AG for repair.
74	HART parameters	Parameter errors that are not critical for the control.
	Status classification	[Maintenance required]
	Recommended action	Confirm error and perform reset.

Error codes – Recommended action		Condensed state message active, when prompted, Err appears. When fault alarms exist, they are displayed here.
75	Info parameters	Info parameter errors that are not critical for the control.
	Status classification	[Maintenance required]
	Recommended action	Confirm error. Check and, if necessary, reset required parameters.
76	No emergency mode	The travel measuring system of the positioner has a self-monitoring function (see Code 62). An emergency mode (open-loop control) is not available for certain actuators, such as double-acting actuators. In this case, the positioner changes to the fail-safe position (SAFE) when a measuring error occurs. During the initialization, the positioner checks whether the actuator has such a function or not.
	Status classification	[No message]
	Recommended action	Merely information, confirm, if necessary. No further action necessary.
77	Program loading error	When the positioner starts operation for the first time after the input signal has been applied, it carries out a self-test (iESinG runs across the display). If the positioner loads the wrong program, the valve moves to the fail-safe position. It is not possible to make the valve leave this fail-safe position again.
	Status classification	Maintenance alarm (cannot be classified)
	Recommended action	Interrupt current and restart positioner. Otherwise, return the positioner to SAMSON AG for repair.
78	Options parameter	Errors in options parameters
	Status classification	[Maintenance required]
	Recommended action	Return the positioner to SAMSON AG for repair.

Diagnosis errors

Error codes – Recommended action		Condensed state message active, when prompted, Err appears. When fault alarms exist, they are displayed here.
79	Diagnostic alarms	Error messages are generated in the extended EXPERTplus diagnostics (refer to EB 8389 on EXPERTplus valve diagnostics)
	Status classification	Maintenance required (cannot be classified)
80	Diagnostic parameters	Errors that are not critical for control.
	Status classification	Maintenance required (cannot be classified)
81	Reference test canceled	An error occurred during plotting the reference graphs for drive signal y steady-state or drive signal y hysteresis. <ul style="list-style-type: none"> • Reference test was interrupted • Reference line for drive signal y steady-state or drive signal y hysteresis was not adopted. Error messages are saved in EEPROM. They cannot be reset.
	Status classification	[Maintenance required]
	Recommended action	Check and, if necessary, perform a new reference test

12 Dimensions in mm

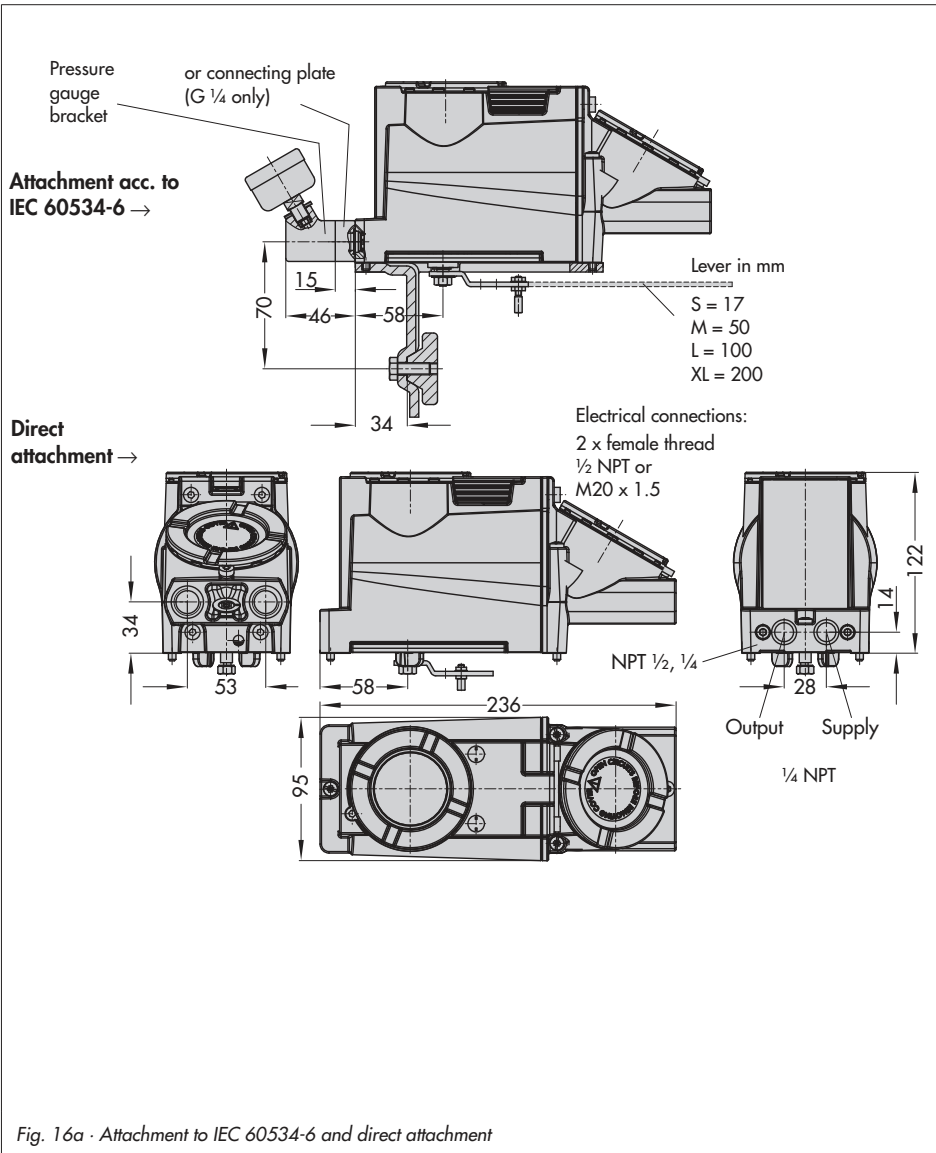

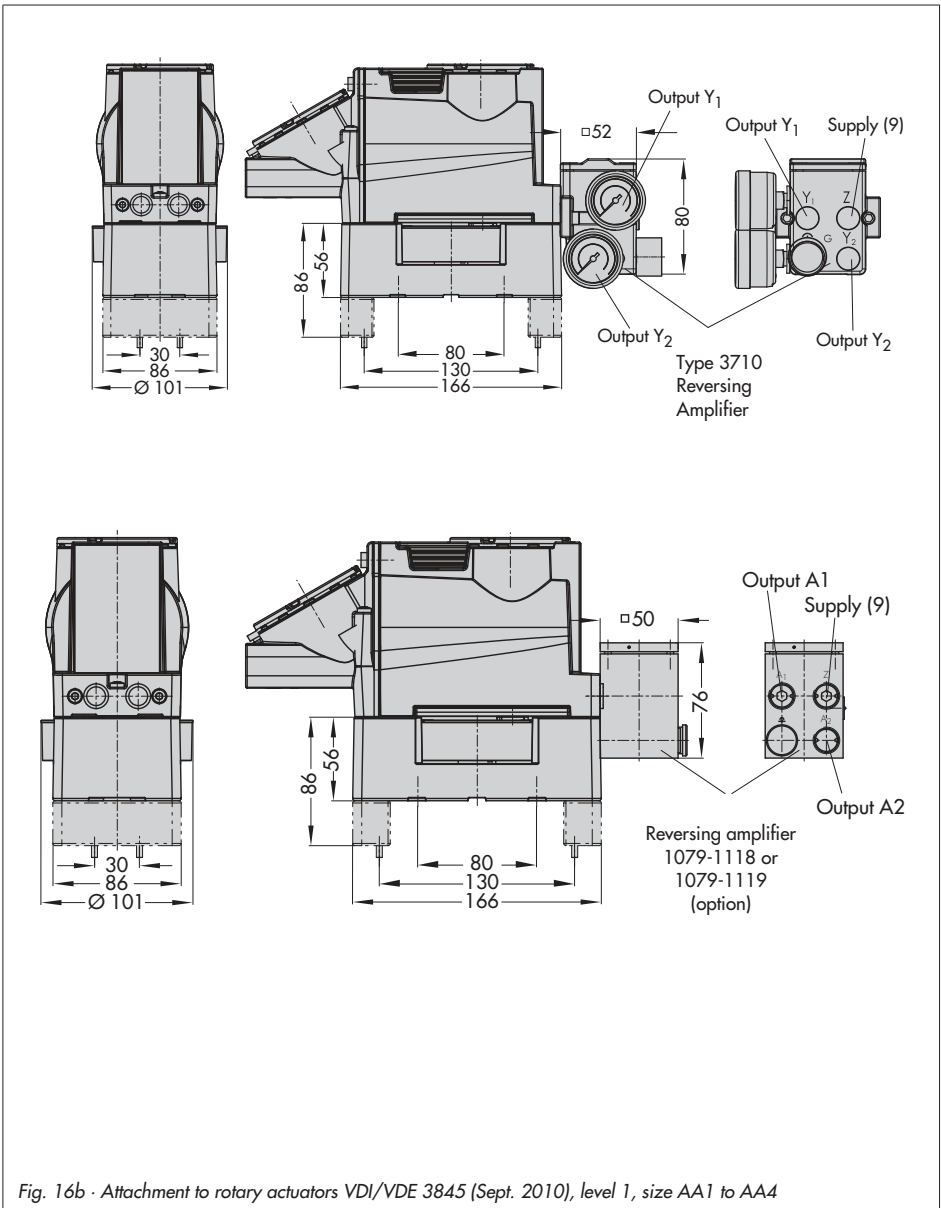
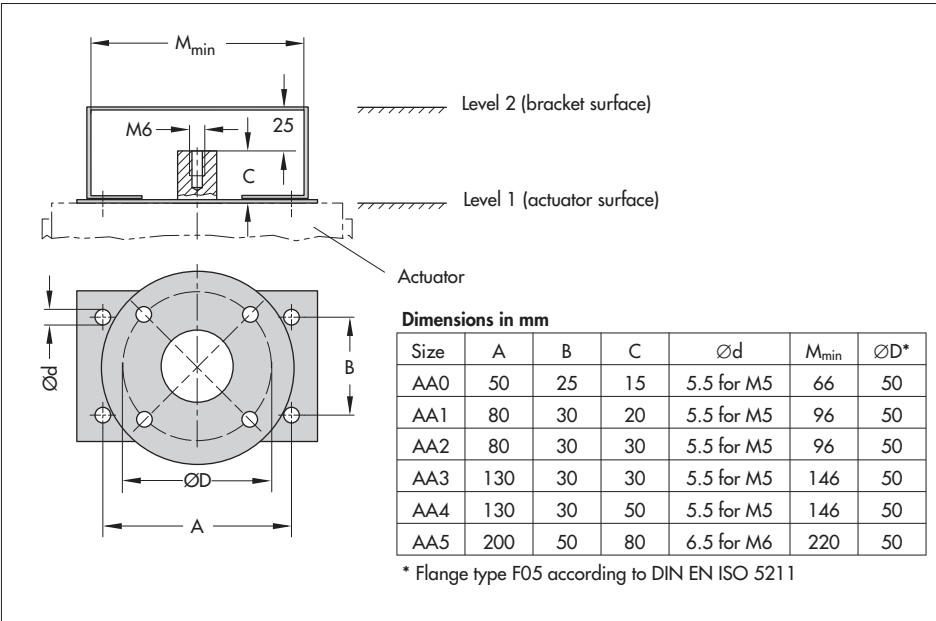

Fig. 16b · Attachment to rotary actuators VDI/VDE 3845 (Sept. 2010), level 1, size AA1 to AA4

12.1 Fixing levels according to VDI/VDE 3845 (September 2010)



13 Appendix

13.1 Selecting the valve characteristic

The characteristics that can be selected in Code **20** are shown in following **in graph form**.

Note: A characteristic can only be defined (user-defined characteristic) using a workstation/operating software (e.g. TROVIS-VIEW).

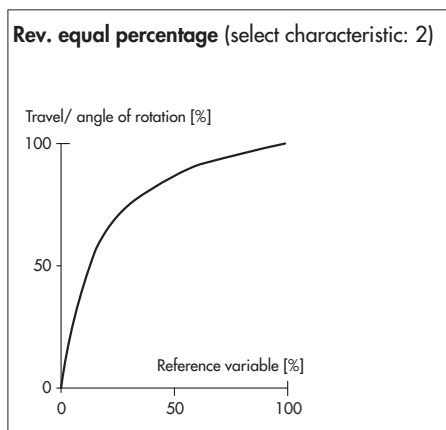
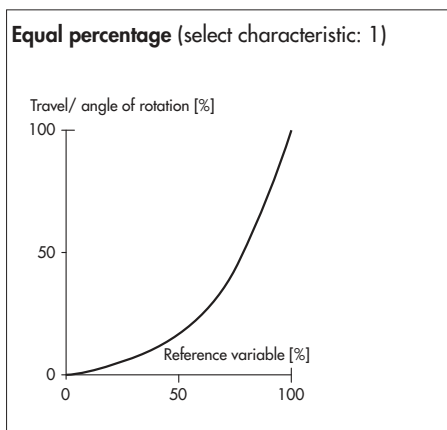
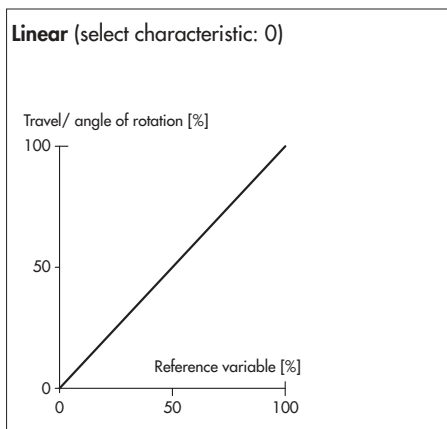

SAMSON butterfly valve linear
(select characteristic: 3)

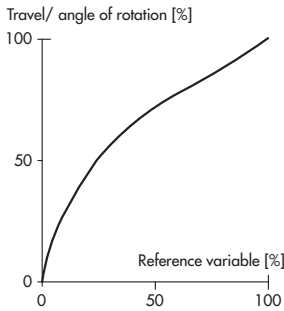

SAMSON butterfly valve equal percentage
(select characteristic: 4)

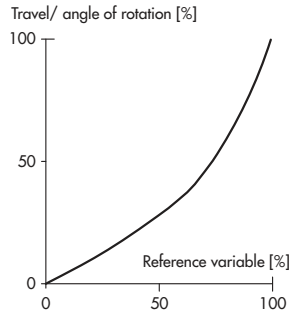

VETEC rotary plug valve linear
(select characteristic: 2)

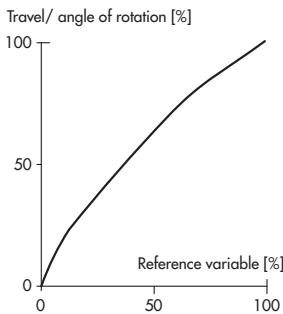

VETEC rotary plug valve equal percentage
(select characteristic: 6)

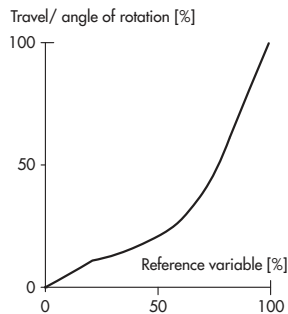

Segmented valve ball linear
(select characteristic: 7)

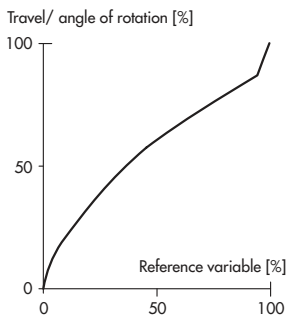

Segmented ball valve equal percentage
(select characteristic: 8)

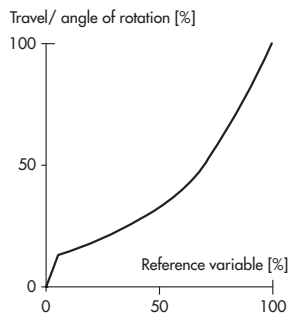



SCHEDULE

- (13)
- (14) **EC-TYPE-EXAMINATION CERTIFICATE PTB 11 ATEX 1014 X**

(1) EC-TYPE-EXAMINATION CERTIFICATE

(Translation)

- (2) Equipment and Protective Systems Intended for Use in Potentially Explosive Atmospheres - Directive 94/9/EC
- (3) EC-type-examination Certificate Number:

PTB 11 ATEX 1014 X

- (4) Equipment: Electro-pneumatic position controller, type 3731-21
- (5) Manufacturer: SAMSON AG Mess- und Regeltechnik
- (6) Address: Weismüllerstr. 3, 60314 Frankfurt am Main, Germany

(7) This examination and any acceptable variation thereto are specified in this certificate and the documents therein referred to.

(8) The Physikalisch-Technische Bundesanstalt, notified body No. 0102, in accordance with Article 9 of the Council Directive 94/9/EC of 23 March 1994, certifies that this equipment has been found to comply with the Essential Health and Safety Requirements relating to the design and construction of equipment and protective systems intended for use in potentially explosive atmospheres, given in Annex II to the Directive.

The examination and test results are recorded in the confidential assessment and test report PTB EX.11-11094.

(9) Compliance with the Essential Health and Safety Requirements has been assumed by compliance with:

- EN 60079-0-2009
- EN 60079-1:2007
- EN 60079-31:2009

(10) If the sign "X" is placed after the certificate number, it indicates that the equipment is subject to special conditions for safe use specified in the schedule to this certificate.

(11) This EC-type-examination Certificate relates only to the design, examination and tests of the specified equipment in accordance to the Directive 94/9/EC. Further requirements of the Directive apply to the manufacturing process and supply of this equipment. These are not covered by this certificate.

(12) The marking of the equipment shall include the following:

II 2 G Ex d IIC T6, T5, T4 Gb and Ex d e IIC T6, T5, T4 Gb

II 2 D Ex tb IIC T60 °C Db IP66

Braunschweig, May 3, 2011

Zertifizierungsstelle: Explosionsschutz

im Auftrag der PTB:

(Signature)

Dr.-Ing. U. Klausmeyer

Direktor und Professor



sheet 1/3

EC-Type-examination Certificate without signature and official stamp shall not be valid. This certificate may be cancelled only without alteration. Extracts and alterations are subject to approval by the Physikalisch-Technische Bundesanstalt. In case of dispute, the German text shall prevail.

(15) Description of equipment
The electro-pneumatic position controller, type 3731-21, is a single- / double-action position controller with communication capabilities, which can be attached to any commercially available lift or partium actuator. The position controller compares the output signal of a control unit within the 4 - 20 mA region with the lift of the control valve and adjusts the pneumatic actuating pressure as an output parameter. The position controller is configured and parameterised with a HART protocol, using the signal line of the 4 - 20 mA signal (version 3731-321). Data are transmitted with a superimposed frequency via the 4 - 20 mA signal cables. The 3731-421 and 3731-521 versions are also available for use with HART communication modules. The position controller complies with the FISCO concept of the FOUNDATION™ Fieldbus specification.

For field application the apparatuses are installed in a metal enclosure of Ex "d" or Ex "d e" types of protection.

Technical data

- Supply voltage: 10 ... 35 VDC
- Signal circuit: 4 ... 20 mA
- Dissipation: max. 7.5 W

(16) Assessment and Test Report PTB EX.11-11094

(17) Special conditions for safe use

Repairs on flameproof joints may only be performed in accordance with the manufacturer's design specifications. Repair on the basis of the values in tables 1 / 2 of EN 60079-1 is not permitted.

Additional notes for safe operation:

Connection conditions

1. When the terminal compartment of the electro-pneumatic position controller, type 3731-21, is designed to Ex-c or type of protection, the following must be complied with:
 - The device shall be connected with suitable cable glands or conduit systems that meet the requirements stipulated in EN 60079-1, sections 13.1 and 13.2, and for which a separate test certificate has been issued. If the device is connected to conduit systems, the required sealing device shall be provided immediately at the enclosure.
 - Cable glands (Pg type glands) and blanking plugs of a simple design must not be used.

sheet 2/3

EC-Type-examination Certificate without signature and official stamp shall not be valid. This certificate may be cancelled only without alteration. Extracts and alterations are subject to approval by the Physikalisch-Technische Bundesanstalt. In case of dispute, the German text shall prevail.

Physikalisch-Technische Bundesanstalt

Braunschweig und Berlin



SCHEDULE TO EC-TYPE-EXAMINATION CERTIFICATE PTB 11 ATEX 1014 X

- Overings that are not used shall be sealed in compliance with the specifications in EN 60079-1, section 11.9.
 - If connection is made in the potentially explosive area, the connecting cable (unconnected cable end) of the electro-pneumatic position controller, type 3731-21, shall be connected in an enclosure that meets the requirements of an approved type of protection in accordance with EN 60079-0, section 1.
- The connecting cable of the electro-pneumatic position controller, type 3731-21, shall be fixed and routed so that it will be adequately protected against mechanical damage.
 - If the temperature at the input parts exceeds 70 °C, temperature-resistant connecting cables shall be used.
 - The electro-pneumatic position controller, type 3731-21, shall be included in the local equipotential bonding system of the potentially explosive area.

These notes and instructions shall accompany each device in an adequate form.

Components attached or installed (terminal compartments, bushings, E-type cable glands, connectors) shall be of technical quality in the same way as the components of the type certificates and shall all be included in the component certificate. The operating conditions specified in the component certificates must be complied with.

Ambient temperature

The field of application of the electro-pneumatic position controller, type 3731-21, is as follows:
 in temperature class T8; to ambient temperatures between -40 °C and +60 °C,
 in temperature class T5; to ambient temperatures between -40 °C and +70 °C, and
 in temperature class T4; to ambient temperatures between -40 °C and +80 °C.

Operating medium in the pneumatic section

- The maximum ingoing-air pressure is 6 bar.
- The equipment operator must ensure that the operating medium does not form an explosive atmosphere. The operating medium must not contain substances whose presence in the medium may cause an explosive atmosphere (no flammable gases, no oxygen or oxygen-enriched gas).

(18) Essential health and safety requirements

Met by compliance with the afore-mentioned Standards.

Zertifizierungssektor Explosionschutz

Braunschweig, May 3, 2011

On behalf of PTB:

(Signature)

Dr.-Ing. U. Kleinmeyer
 Direktor und Professor

3 pages, correct and complete as regards content.

By order



Dipl.-Phys. U. Volker

Braunschweig, June 17, 2011

sheet 3/3

EC-type examination Certificates without signature and official stamp shall not be valid. The certificate may be cancelled only without signature, extracts or copies of the certificate shall not be made.

Physikalisch-Technische Bundesanstalt • Bundesallee 100 • 38116 Braunschweig • GERMANY

1. SUPPLEMENT
according to Directive 94/9/EC Annex III.6

to EC-TYPE-EXAMINATION CERTIFICATE PTB 11 ATEX 1014 X

(Translation)

Equipment: Electro-pneumatic positioner, type 3731-21..

Marking: **Ex** I 2 G Ex db IIC T6 or II 2 G Ex db eb IIC T6 or
II 2 G Ex db [Ia] IIC T6 or II 2 G Ex Ia IIC T6 and
II 2 D Ex tb IIC T80 °C IP66

Manufacturer: SAMSON AG Mess- und Regeltechnik

Address: Weismüllerstr. 3, 60314 Frankfurt, Germany

Description of supplements and modifications

The electro-pneumatic positioners of types 3731-421-....., 4 and 3731-521-....., 4 are designed to type of protection Intrinsic Safety Ex ia. Communication is carried out alternatively according to PROFIBUS PA (type 3731-..4) or FOUNDATION Fieldbus specification (type 3731-..5).

Types 3731-2103 / binary input and 3731-2104 / forced breathing are introduced as an option. For relationship between explosion group, temperature class and the permissible ambient temperature range, reference is made to the following table:

Ex ia IIC/IIB	T6	+60 °C
	T5	-40 °C ≤T _a ≤+70 °C
	T4	+80 °C

When using metal cable glands the minimum temperature is -40 °C.

The electrical data are presented in summary

Electrical data

Supply voltage: 10 ... 35 V DC, U_n = 60 V
Signal circuit: 4 ... 24 V AC
Power dissipation: max. 7.5 W

1. SUPPLEMENT TO EC-TYPE-EXAMINATION CERTIFICATE PTB 11 ATEX 1014 X

or

BUS-connection signal circuit.....type of protection Ex ia IIC/IIB

For relationship between type of protection and the permissible electrical data reference is made to the following tables.

Type 3731-421.....4

PROFIBUS PA	
Ex ia IIC/IIB	
U _i =	17.5 V DC
I _i =	380 mA
P _i =	5.32 W

or

Type 3731-521.....4

Foundation™ Fieldbus	
Ex ia IIB	
Ex ia IIC	Ex ia IIB
U _i = 24 V DC	U _i = 24 V DC
I _i = 380 mA	I _i = 380 mA
P _i = 1.04 W	P _i = 2.58 W

C_i = 5 nF
L_i = 10 µH

Note: Only one of the following options will be applied in each case.

Option Forced Breathing.....type of protection Ex ia IIC/IIB only for connection to a certified intrinsically safe circuit

Maximum values:

U_i = 28 V
I_i = 115 mA

or

U_i = 32 V
I_i = 87.6 mA

C_i = 7.26 nF
L_i negligibly low

Physikalisch-Technische Bundesanstalt

Braunschweig und Berlin



1. SUPPLEMENT TO EC-TYPE-EXAMINATION CERTIFICATE PTB 11 ATEX 1014 X

Option Binary Input,type of protection Ex ia IIC/IIB
(terminals A, B, C) only for connection to a certified intrinsically safe circuit

Maximum values:

U_i = 25 V

I_i = 150 mA

C_i = 110 nF

L_i negligibly low

The special conditions, the additional notes for safe operation and all other specifications of the EC-type examination certificate apply without changes.

Applied standards

EN 60079-0:2009 EN 60079-1:2007 EN 60079-7:2007

EN 60079-11:2012 EN 60079-31:2009

Test report: PTB Ex 12-21178



Zertifizierungs-Direktor
On behalf of PTB:

Braunschweig, July 26, 2012

Dr.-Ing. V. Joharić/Dr. Ing. M. W. ...
Direktor und Professor

TRANSLATION

EC TYPE EXAMINATION CERTIFICATION

- (1)
- (2) Equipment and Protective Systems Intended for Use in Potentially Explosive Atmospheres – **Directive 94/9/EC**
- (3) EC Type Examination Certificate Number
PTB 05 ATEX 1058
- (4) Equipment: Model 3731-321, Electropneumatic Positioner
- (5) Manufacturer: SAMSON AG, Mess- und Regeltechnik
- (6) Address: Weismüllerstr. 3, D-60314 Frankfurt, Germany
- (7) The equipment and any acceptable variations thereof are specified in the schedule to this certificate.
- (8) The Physikalisch-Technische Bundesanstalt, notified body number 0102 in accordance with Article 9 of the Council Directive 94/9/EC of 23 March 1994, certifies that this equipment has been found to comply with the Essential Health and Safety Requirements relating to the design and construction of equipment and protective systems intended for use in potentially explosive atmospheres as specified in Annex II to the Directive.

The examination and test results are recorded in confidential report
PTB Ex. 05-13010.

- (9) The Essential Health and Safety Requirements are satisfied by compliance with
EN 50014:1997 + A1 + A2 EN 50018: 2000 + A1 EN50019: 2000
EN 50281-1-1: 1998 + A1

- (10) If the sign "X" is placed after the certificate number, it indicates that the equipment is subject to special conditions for safe use specified in the schedule to this certificate.

EC Type Examination Certificates without signature and seal are invalid.
This EC Type Examination Certificate is valid only if signed and sealed.
Extracts or changes shall require the prior approval of the Physikalisch-Technische Bundesanstalt.

- (11) This EC Type Examination Certificate relates only to the design and examination of the specified equipment in compliance with Directive 94/9/EC. Further requirements of this Directive apply to the manufacture and supply of this equipment. These requirements are not covered by this Certificate.

- (12) The marking of the equipment shall include the following:

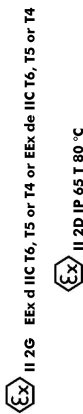

Zertifizierungsstelle Explosionsschutz Braunschweig, 19 July 2005
By order

(Signature) (Seal)

Dr. Ing. M. Thedens

EC Type Examination Certificates without signature and seal are invalid.
This EC Type Examination Certificate is valid only if signed and sealed.
Extracts or changes shall require the prior approval of the Physikalisch-Technische Bundesanstalt.

(13) S c h e d u l e

(14) EC TYPE EXAMINATION CERTIFICATE No. PTB 05 ATEX 1058

(15) Description of Equipment

The Model 3731-321 Electro pneumatic Positioner is a single- or double acting positioner with communication capability intended for attachment to any current linear or rotary actuator. The positioner compares the control signal of 4 to 20 mA from a control system with the travel of the control valve and supplies a pneumatic pressure signal, configuration and parameterization of the positioner are achieved by means of the HART protocol via the signal line for the 4 to 20 mA signal. Data transmission is achieved by a superposed frequency on the 4 to 20 mA signal lines.

Technical Data

Supply voltage: 10 to 35 V DC
Signal circuit: 4 to 20 mA
Power dissipation: max. 7.5 W

(16) Test Report: PTB Ex 05-13010

(17) Special conditions for safe use

None

Additional notes on safe operation

Connection requirements for the terminal compartment version with type of protection "flameproof enclosure"

1. The Model 3731-321 Electro pneumatic Positioner shall be connected via suitable cable entries or conduit systems satisfying the requirements of En 50018 Clause 13.1 and 13.2 and for which a separate certificate has been issued.
2. Cable entries (Pg glands) and simple closing plugs must not be used.
3. Apertures not used shall be closed in compliance with En 50018 Class 11, .9.
4. The connecting cable of the Model 3731-321 Electro pneumatic Positioner shall be installed rigidly and in such a manner that it is protected adequately from mechanical damage.
5. If the temperature at the entry facilities exceeds 70 °C adequately temperature-resistance connecting leads shall be used.

EC Type Examination Certificates without signature and seal are invalid.
This EC Type Examination Certificate may only be reproduced in its entirety and without any changes, schedule included.
Edits or changes shall require the prior approval of the Physikalisch-Technische Bundesanstalt.

Physikalisch-Technische Bundesanstalt, Bundesallee 100, D-38116 Braunschweig
Ph50-3731.doc

6. The model 3731-321 Electro pneumatic Positioner shall be included in the local equal-potential bonding system.

These notes shall be attached to each unit in a suitable form.

Ambient temperature

The Model 3731-321 Electro pneumatic Positioner is intended for use in, temperature class T6 with ambient temperatures from -40 °C to + 60 °C temperature class T5 with ambient temperatures from -40 °C to + 70 °C temperature class T4 with ambient temperatures from -40 °C to + 80 °C

Pneumatic working medium

1. The maximum supply pressure is 6 bar.
2. The user of the apparatus shall ensure that the working medium cannot form an explosive atmosphere, i.e. only gases may be used that are free of substances the existence of which could result in an explosive atmosphere (non-combustible gases and no oxygen or gases enriched with oxygen).

(18) Basic Health and Safety Requirements

Satisfied by compliance with the standards specified above

Zertifizierungsstelle Explosionschutz

By order

Braunschweig, 19 July 2005

(Signature) (seal)

Dr. Ing. M. Theden

EC Type Examination Certificates without signature and seal are invalid.
This EC Type Examination Certificate may only be reproduced in its entirety and without any changes, schedule included.
Edits or changes shall require the prior approval of the Physikalisch-Technische Bundesanstalt.

Physikalisch-Technische Bundesanstalt, Bundesallee 100, D-38116 Braunschweig
Ph50-3731.doc

T R A N S L A T I O N

A D D E N D U M N o.:

in compliance with Directive 94/9/EC Annex III Clause 6
to the EC Type Examination Certificate PTB 05 ATEX 1058

Equipment: Model 3731-21 Electro pneumatic Positioner

 II 2G EEx d IIC T6, T5 or T4, or
EEx de IIC T6, T5 or T4

 II 2D IP 65 or IP 66 T 80°C

Manufacturer: SAMSON AG Mess- und Regeltechnik

Address: Weismüllerstr. 3, D-60314 Frankfurt, Germany

Description of the additions and modifications

The model versions 3731-421(Profibus PA) and 3731-521 (FOUNDATION Fieldbus) are also included
in this Certificate.

The type of protection of the enclosure has been extended to include IP 66 in compliance with
EN 60529.

Applicable standards

EN 50014:1997 + A1 + A2
EN 60079-7:2003
EN 50018:2000 + A1
EN 50281-1-1:1998 + A1

Test report: **PTB Ex 06-1621**

Zertifizierungsstelle Explosionschutz
By order Braunschweig, 21 July 2006

(Signature) (Seal)

Dr. Ing. M. Theclens
Regierungsrat

This EC Type Examination Certificate without signature and seal are invalid.
The EC Type Examination Certificate without signature and seal are invalid.
The EC Type Examination Certificate without signature and seal are invalid.
require the prior approval of the Physikalisch-Technische Bundesanstalt.

Index

A

Accessories	30, 32
Additional equipment	
binary contact	9
binary input	10
forced venting	9
position transmitter	9
Article code	7
Attachment	
acc. to IEC 60534-6 (NAMUR)	22
direct attachment	
to Type 3277 Actuator	20
to Type 3277-5 Actuator	17
reversing amplifier	28
to Type 3510 Micro-flow Valve	24
to rotary actuators	26
Automatic mode	61

B

Bar elements	42
Blocking position	
canceling	57

C

Cable entry	38
Characteristic	
selecting	70, 87
Closed position of valve	49
Code list	65 - 83
Communication	12
HART	10, 12, 45
Condensed state	63
Configuration	
using TROVIS-VIEW	10
Configuration enabled	43, 60

Connections

electrical	36 - 37, 41
pneumatic	34

D

Default values	59
Design, positioner	8
Dimensions	84 - 86
Display	42, 44
turned by 180°	47

E

Electrical connections	36, 39
Enable configuration	60
Error messages	
confirming	63
data errors	81
diagnosis errors	83
hardware errors	79
initialization errors	76
operational errors	78
Explosion protection	13

F

Fail-safe position	62
------------------------------	----

H

HART® communication	45
HART® protocol	40

I

Initialization

MAN manually selected range	50, 53
MAX maximum range	50 - 51
NOM nominal range	50, 52
SUB substitute calibration	50, 55

M

- Maintenance 64
- Malfunction. 62
- Manual mode 61
- Mounting parts 30, 32 - 33

O

- Operating modes 42, 61
- Operating range
 - MAN manually selected range . . 50, 53
 - MAX maximum range. 50 - 51
 - NOM nominal range 50, 52
 - checking 48
- Operator controls. 42 - 45
- Output
 - (signal pressure) 35

P

- Pneumatic connections 34 - 35
- Principle of operation, positioner 8

R

- Reset 59
- Reversing amplifier 28
- Rotary pushbutton 42

S

- Serial interface 10, 42
- Servicing 64
- Signal pressure 35
 - indicating 35
 - limiting 47
- Start-up 46, 59
- Status messages 42
- Substitute calibration 50, 55
- Supply pressure. 35

T

- Technical data 12 - 13
 - additional equipment 14
- Travel tables 16

V

- Valve characteristic, selecting 87

Z

- Zero calibration 58



SAMSON AG · MESS- UND REGELTECHNIK
Weismüllerstraße 3 · 60314 Frankfurt am Main, Germany
Phone: +49 69 4009-0 · Fax: +49 69 4009-1507
Internet: <http://www.samson.de>

EB 8387-3 EN

2017-06