

MOUNTING AND OPERATING INSTRUCTIONS

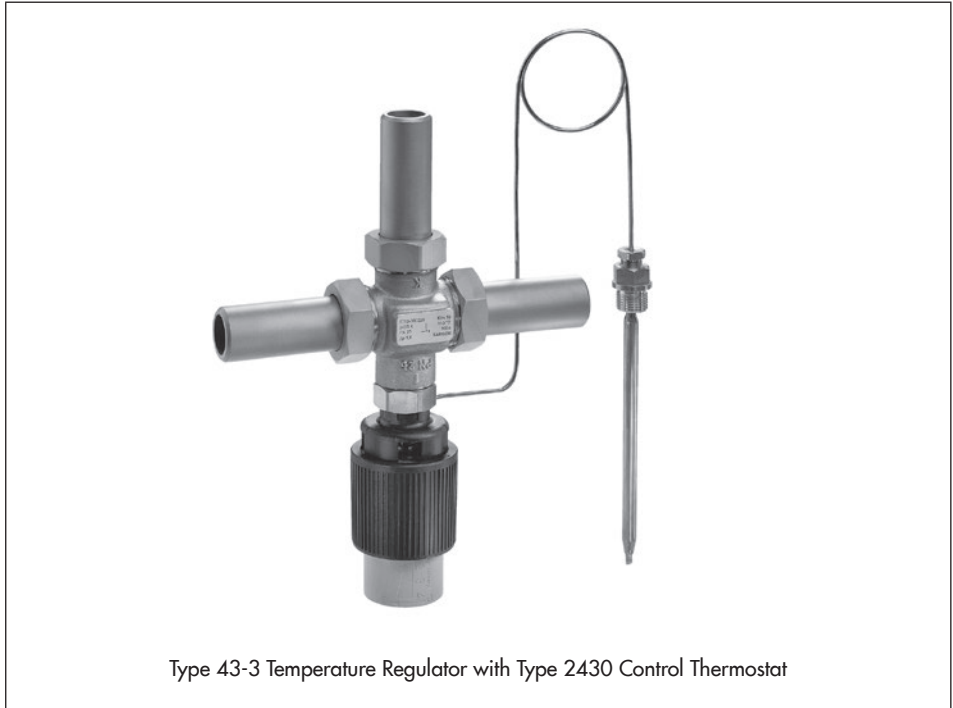

EB 2173 EN

Translation of original instructions



Type 43-3 Temperature Regulator with Type 2430 Control Thermostat

Type 43-3 Temperature Regulator Self-operated Regulators

Edition July 2023



Note on these mounting and operating instructions

These mounting and operating instructions assist you in mounting and operating the device safely. The instructions are binding for handling SAMSON devices. The images shown in these instructions are for illustration purposes only. The actual product may vary.

- For the safe and proper use of these instructions, read them carefully and keep them for later reference.
- If you have any questions about these instructions, contact SAMSON's After-sales Service (aftersaleservice@samsongroup.com).



The mounting and operating instructions for the devices are included in the scope of delivery. The latest documentation is available on our website at www.samsongroup.com > **Service & Support** > **Downloads** > **Documentation**.

Definition of signal words

DANGER

Hazardous situations which, if not avoided, will result in death or serious injury

WARNING

Hazardous situations which, if not avoided, could result in death or serious injury

NOTICE

Property damage message or malfunction

Note

Additional information

Tip

Recommended action

1	Safety instructions and measures	1-1
1.1	Notes on possible severe personal injury	1-4
1.2	Notes on possible personal injury	1-5
1.3	Notes on possible property damage	1-6
2	Markings on the device	2-1
2.1	Valve nameplate	2-1
2.2	Nameplate of control thermostat	2-1
2.3	Location of the nameplate on valve and control thermostat	2-2
2.4	Material identification number	2-2
3	Design and principle of operation	3-1
3.1	Additional fittings.....	3-3
3.2	Technical data	3-5
4	Shipment and on-site transport	4-1
4.1	Accepting the delivered goods	4-1
4.2	Removing the packaging from the regulator	4-1
4.3	Transporting and lifting the regulator	4-1
4.4	Storing the regulator	4-2
5	Installation	5-1
5.1	Installation conditions	5-1
5.2	Preparation for installation.....	5-3
5.3	Installation.....	5-5
5.3.1	Installing the regulator	5-5
5.3.2	Cleaning the pipeline	5-6
5.4	Testing the regulator	5-6
5.4.1	Leakage	5-7
5.4.2	Pressure test.....	5-8
5.5	Insulation	5-8
6	Start-up	6-1
6.1	Start-up and putting the device back into operation	6-2
6.2	Starting up the plant.....	6-2
7	Operation	7-1
7.1	Adjusting the temperature set point.....	7-1
8	Malfunctions	8-1
8.1	Troubleshooting	8-1
8.1.1	Temperature regulators for heating applications.....	8-1
8.1.2	Temperature regulators for cooling applications.....	8-3

Contents

8.2	Emergency action	8-5
9	Servicing.....	9-1
9.1	Preparing the valve for service work	9-2
9.2	Installing the regulator after service work	9-2
9.3	Service work.....	9-2
9.4	Cleaning the seat and plug	9-4
9.5	Ordering spare parts and operating supplies	9-4
10	Decommissioning	10-1
11	Removal	11-1
11.1	Removing the control thermostat	11-1
11.2	Removing the valve from the pipeline.....	11-1
12	Repairs	12-1
12.1	Returning devices to SAMSON	12-1
13	Disposal.....	13-1
14	Certificates	14-1
15	Annex.....	15-1
15.1	Tightening torques.....	15-1
15.2	Tools	15-1
15.3	Lubricants.....	15-1
15.4	Spare parts and accessories	15-1
15.5	After-sales service	15-2

1 Safety instructions and measures

Intended use

The SAMSON Type 43-3 Regulator is a temperature regulator with three-way valve for mixing and diverting service. The regulator consists of a Type 2433 Valve and a Type 2430 Control Thermostat. The valve and control thermostat are delivered separately and must be assembled according to the instructions in these mounting and operating instructions.

The self-operated regulator is used to control the temperature in the plant to the adjusted set point. The Type 43-3 Regulator is used to control water.

The regulator is designed to operate under exactly defined conditions (e.g. operating pressure, process medium, temperature). Therefore, operators must ensure that the regulator is only used in operating conditions that meet the specifications used for sizing the regulator at the ordering stage. In case operators intend to use the controllers in applications or conditions other than those specified, contact SAMSON.

SAMSON does not assume any liability for damage resulting from the failure to use the device for its intended purpose or for damage caused by external forces or any other external factors.

→ Refer to the technical data and nameplate for limits and fields of application as well as possible uses.

Reasonably foreseeable misuse

The regulators are not suitable for the following applications:

- Use outside the limits defined during sizing and by the technical data
- Use outside the limits defined by the additional fittings mounted on the regulator

Furthermore, the following activities do not comply with the intended use:

- Use of non-original spare parts
- Performing service and repair work not described

Safety features

The Type 43-3 Temperature Regulator does not have any special safety features.

Qualifications of operating personnel

The regulator must be mounted, started up, serviced and repaired by fully trained and qualified personnel only; the accepted industry codes and practices must be observed. According to these mounting and operating instructions, trained personnel refers to individuals who are

Safety instructions and measures

able to judge the work they are assigned to and recognize possible hazards due to their specialized training, their knowledge and experience as well as their knowledge of the applicable standards.

Personal protective equipment

We recommend checking the hazards posed by the process medium being used (e.g.

▶ GESTIS (CLP) hazardous substances database). Depending on the process medium and/or the activity, the protective equipment required includes:

- Protective clothing, safety gloves and eye protection in applications with hot, cold and/or corrosive media
- Wear hearing protection when working near the valve. Follow the instructions given by the plant operator.
- Check with the plant operator for details on further protective equipment.

Revisions and other modifications

Revisions, conversions or other modifications of the product are not authorized by SAMSON. They are performed at the user's own risk and may lead to safety hazards, for example. Furthermore, the product may no longer meet the requirements for its intended use.

Warning against residual hazards

To avoid personal injury or property damage, plant operators and operating personnel must prevent hazards that could be caused in the regulator by the process medium, the operating pressure or by moving parts by taking appropriate precautions. Plant operators and operating personnel must observe all hazard statements, warnings and caution notes in these mounting and operating instructions.

Hazards resulting from the special working conditions at the installation site of the regulator must be identified in a risk assessment and prevented through the corresponding safety instructions drawn up by the operator.

We also recommend checking the hazards posed by the process medium being used (e.g.

▶ GESTIS (CLP) hazardous substances database).

- Observe safety measures for handling the device as well as fire prevention and explosion protection measures.

These mounting and operating instructions deals with the standard version of the device. Components of the device that differ to those used for the standard version described in this document can be exchanged with other certain SAMSON components. The residual hazards of these components are described in the associated mounting and operating instructions (see documents listed under 'Referenced documentation').

Responsibilities of the operator

Operators are responsible for proper use and compliance with the safety regulations. Operators are obliged to provide these mounting and operating instructions as well as the referenced documents to the operating personnel and to instruct them in proper operation. Furthermore, operators must ensure that operating personnel or third parties are not exposed to any danger.

Operators are additionally responsible for ensuring that the limits for the product defined in the technical data are observed. This also applies to the start-up and shutdown procedures. Start-up and shutdown procedures fall within the scope of the operator's duties and, as such, are not part of these mounting and operating instructions. SAMSON is unable to make any statements about these procedures since the operative details (e.g. differential pressures and temperatures) vary in each individual case and are only known to the operator.

Responsibilities of operating personnel

Operating personnel must read and understand these mounting and operating instructions as well as the referenced documents and observe the specified hazard statements, warnings and caution notes. Furthermore, operating personnel must be familiar with the applicable health, safety and accident prevention regulations and comply with them.

Referenced standards, directives and regulations

The DVGW type examination certificate is included in the 'Certificates' section.

According to the ignition hazard assessment performed in accordance with Clause 5.2 of ISO 80079-36, the non-electrical regulators do not have their own potential ignition source even in the rare incident of an operating fault. As a result, they do not fall within the scope of Directive 2014/34/EU.

→ For connection to the equipotential bonding system, observe the requirements specified in Clause 6.4 of EN 60079-14 (VDE 0165-1).

Referenced documentation

The following documents apply in addition to these mounting and operating instructions:

- Mounting and operating instructions for

Safety instructions and measures

- | | | |
|------|--|-----------|
| e.g. | Type 2430 Control Thermostat | ▶ EB 2430 |
| e.g. | Type 2403 Safety Temperature Monitor (STM) | ▶ EB 2183 |
| e.g. | Type 2439 Safety Temperature Limiter (STL) | ▶ EB 2185 |
| e.g. | Type 1 NI Strainer | ▶ EB 1010 |
| e.g. | Type 2 NI Strainer | ▶ EB 1015 |
- Data sheets for
- | | | |
|------|---|----------|
| e.g. | Accessories: Double adapter · Manual adjuster · Intermediate insulating piece | ▶ T 2176 |
| e.g. | Typetested safety devices | ▶ T 2181 |
| e.g. | Type 2403 Safety Temperature Monitor (STM) | ▶ T 2183 |
| e.g. | Type 2439 Safety Temperature Limiter (STL) | ▶ T 2185 |
| e.g. | Type 1 NI Strainer | ▶ T 1010 |
| e.g. | Type 2 NI Strainer | ▶ T 1015 |
- Mounting and operating instructions as well as data sheets for additional fittings (e.g. shut-off valves, pressure gauges etc.).

1.1 Notes on possible severe personal injury

DANGER

Risk of bursting in the regulator.

Regulators and pipelines are pressure equipment. Impermissible pressure or improper opening of the regulator can lead to regulator components bursting.

- Observe the maximum permissible pressure for regulator and plant.
- Before starting any work on the regulator, depressurize all plant sections affected as well as the regulator.
- Drain the process medium from all the plant sections affected as well as the regulator.

1.2 Notes on possible personal injury

WARNING

Damage to health relating to the REACH regulation.

If a SAMSON device contains a substance listed as a substance of very high concern on the candidate list of the REACH regulation, this is indicated on the SAMSON delivery note.

- Information on safe use of the part affected. ► www.samsongroup.com/en/about-samson/material-compliance/reach-regulation/

Risk of personal injury due to incorrect operation, use or installation as a result of information on the regulator being illegible.

Over time, markings, labels and nameplates on the regulator may become covered with dirt or become illegible in some other way. As a result, hazards may go unnoticed and the necessary instructions not followed. There is a risk of personal injury.

- Keep all relevant markings and inscriptions on the device in a constantly legible state.
- Immediately renew damaged, missing or incorrect nameplates or labels.

Risk of burn injuries due to hot or cold components and pipelines.

Depending on the process medium, regulator components and pipelines may get very hot or cold and cause burn injuries.

- Allow components and pipelines to cool down or warm up to the ambient temperature.
- Wear protective clothing and safety gloves.

Risk of hearing loss or deafness due to loud noise.

The noise emissions depend on the valve version, plant facilities and process medium.

- Wear hearing protection when working near the valve. Follow the instructions given by the plant operator.

WARNING

Risk of personal injury due to residual process medium in the regulator.

While working on the regulator, residual process medium can escape and, depending on its properties, may lead to personal injury, e.g. (chemical) burns.

- If possible, drain the process medium from all the plant sections affected and the regulator.
- Wear protective clothing, safety gloves and eye protection.

1.3 Notes on possible property damage

NOTICE

Risk of regulator damage due to incorrectly attached slings.

- Do not attach load-bearing slings to the regulator.

Risk of regulator damage due to unsuitable medium properties.

The regulator is designed for a process medium with defined properties.

- Only use the process medium specified for sizing the equipment.

Risk of regulator damage due to contamination (e.g. solid particles) in the pipeline.

The plant operator is responsible for cleaning the pipelines in the plant.

- Flush the pipelines before start-up.

Risk of regulator damage due to the use of unsuitable lubricants.

The lubricants to be used depend on the regulator material. Unsuitable lubricants may corrode and damage surfaces.

- Only use lubricants approved by SAMSON.
When in doubt, consult SAMSON.

! NOTICE

Risk of leakage and regulator damage due to excessively high or low tightening torques.

Observe the specified torques when tightening regulator components. Excessive tightening torques lead to parts wearing out more quickly. Parts that are too loose may cause leakage.

→ Observe the specified tightening torques (see 'Tightening torques' in Annex).

Risk of excess pressure damaging plant sections due to construction-related seat leakage through the regulator.

→ Always install a safety device (e.g. safety excess pressure valve or safety relief valve) in the plant.

Risk of regulator damage due to the use of unsuitable tools.

Certain tools are required to work on the regulator.

→ Only use tools approved by SAMSON.
When in doubt, consult SAMSON.

Risk of the process medium being contaminated through the use of unsuitable lubricants and/or contaminated tools and components.

→ Keep the regulator and the tools used free from solvents and grease.

→ Make sure that only suitable lubricants are used.

Incorrect control due to the formation of ice on the regulator.

Medium temperatures below 0 °C may cause ice to form on the regulator, depending on the air humidity. This may affect, in particular, the functioning of the plug or control thermostat stem guide.

→ Prevent the formation of ice by taking appropriate precautions (e.g. enclosure, trace heater etc.). The plant operator is responsible for selecting and implementing appropriate precautions. See the 'Installation' section.

NOTICE

Risk of irreparable regulator damage caused by the regulator components being taken apart.

The control thermostat is an inseparable hydraulic unit consisting of a control thermostat, capillary tube and temperature sensor. If these components are dismantled (e.g. removal of the capillary tube), the regulator will be irreparably damaged and will no longer be able to fulfill its control task.

- Do not dismantle the regulator.
- Only perform allowed activities on the regulator.
- Contact SAMSON's After-sales Service before replacing spare parts.

Note

SAMSON's After-sales Service can support you concerning lubricant, tightening torques and tools approved by SAMSON.

2 Markings on the device

2.1 Valve nameplate

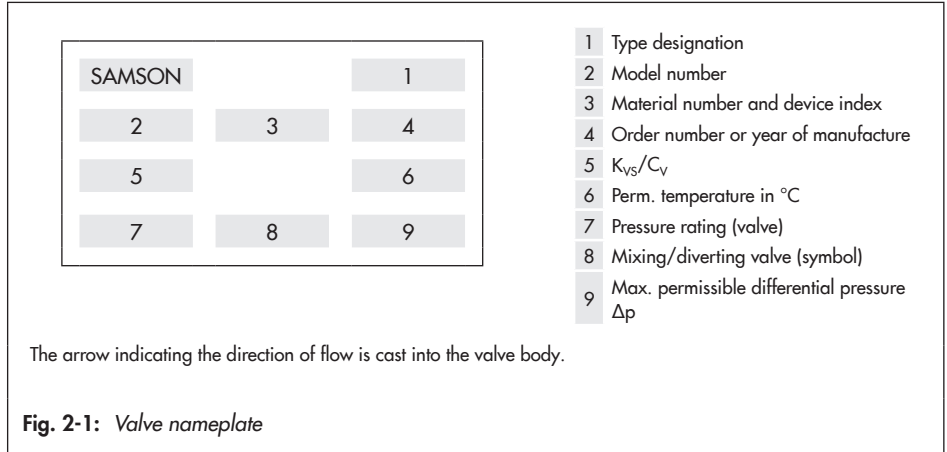

2.2 Nameplate of control thermostat

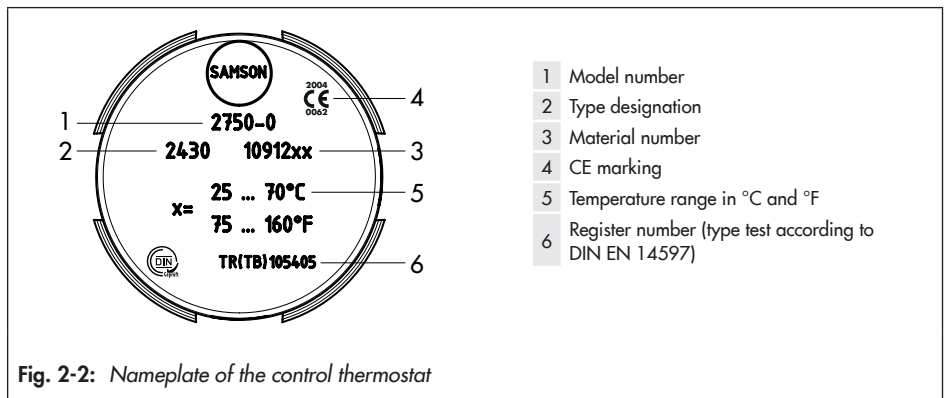

2.3 Location of the nameplate on valve and control thermostat

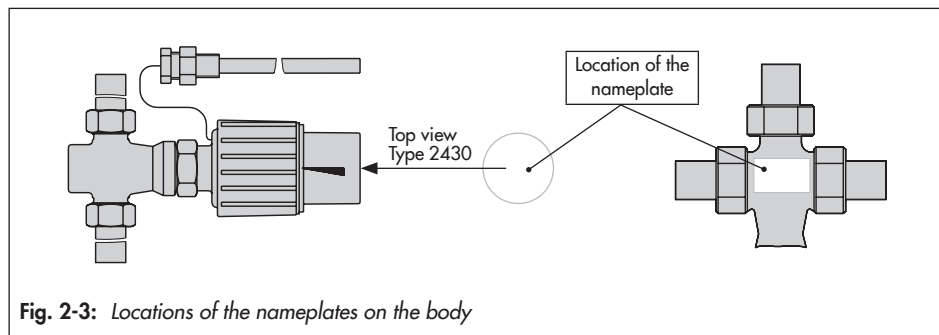

Fig. 2-3: Locations of the nameplates on the body

2.4 Material identification number

The material is indicated on the body of the Type 2433 Valve. Specifying the material number, you can contact us to find out more details. The material number is specified on the nameplate ("Material number and device index", 3).

For more details on the nameplate, see section 2.1 and section 2.2.

3 Design and principle of operation

→ See Fig. 3-1

The regulator consists of a Type 2433 Three-way Valve (designed as mixing or diverting valve) and a Type 2430 Control Thermostat with set point adjuster, a capillary tube and temperature sensor.

A temperature sensor operating according to the adsorption principle is used as standard.

i Note

Details on the Type 2430 Control Thermostat with a temperature sensor operating according to the vapor pressure principle can be found in the mounting and operating instructions ► EB 2430.

The valve body is made of red brass or spheroidal graphite iron.

The Type 2430 Control Thermostat is attached to the valve body (1) using the coupling nut (5).

The temperature regulators work according to the adsorption principle. The temperature of the medium creates a pressure in the sensor (48) which is proportional to the measured temperature. This pressure is transferred through the capillary tube (11) to the operating element (12) and converted into a positioning force. This force causes the pin of the operating element (10) to move the plug stem (4) with the plug (3). The plug is not pressure-balanced.

By turning the set point adjuster (8), the point of response is changed over the plug

spring. As a result, the temperature set point is changed.

Depending on its plug arrangement, the three-way valve is either used for mixing or diverting service.

In mixing valves, the process media to be mixed enter at valve ports A and B. The combined flow exits the valve at port AB. When the temperature rises, port A opens and port B closes.

In diverting valves, in contrast, the process medium enters at the valve port AB and the partial flows exit at ports A and B. When the temperature rises, port A closes and port B opens.

Version with safety thermostat

When a Type 2439 or Type 2403 Safety Thermostat is attached to the valve or the regulator, this combination functions as a safety temperature limiter (TR/STL) or a safety temperature monitor (TR/STM).

Details in mounting and operating instructions

► EB 2185 (STL); ► EB 2083 (STM).

Version with double adapter

The temperature regulator can be equipped with a double adapter to connect an additional control thermostat to control a further control variable.

See Data Sheet ► T 2176.

Design and principle of operation

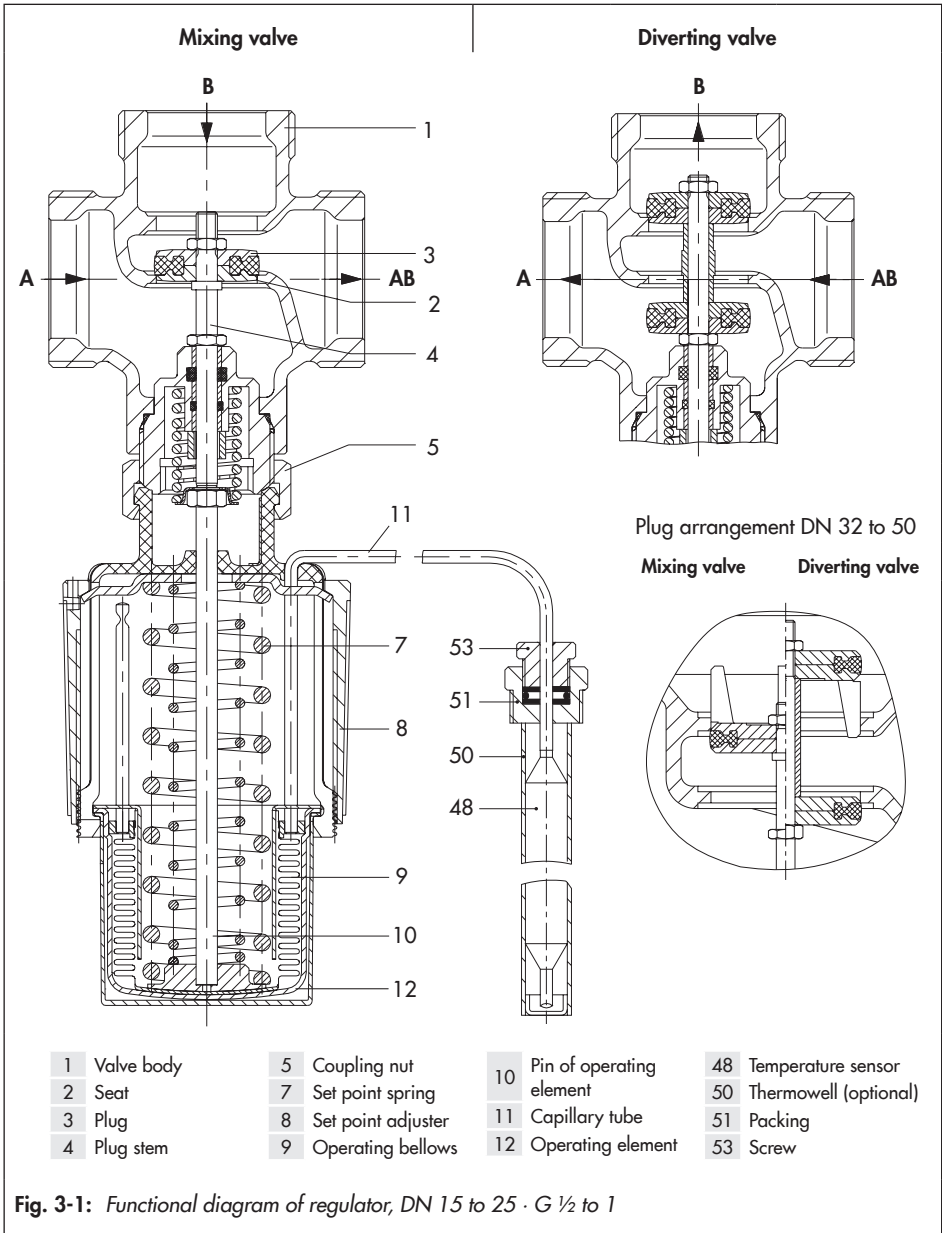

Fig. 3-1: Functional diagram of regulator, DN 15 to 25 · G ½ to 1

Version with handwheel

For the manual operation of the valve. The manual adjuster can either be attached directly to the valve or at the double adapter instead of a control thermostat.

See Data Sheet ► T 2176.

i Note

The Type 43-3 Regulator is not a safety valve. If necessary, a suitable overpressure protection must be installed on site in the plant section.

3.1 Additional fittings

Strainers

We recommend installing a SAMSON strainer upstream of the valve in the flow pipe. It prevents solid particles in the process medium from damaging the regulator.

- ➔ Do not use the strainer to permanently filter the process medium.
- ➔ Select a strainer (mesh size) suitable for the process medium.

i Note

Any impurities carried along by the process medium may impair the proper functioning of the regulator. We recommend installing a strainer (e.g. SAMSON Type 1 NI) upstream of the temperature regulator (► EB 1010).

Thermometer

Install a thermometer to monitor the temperature prevailing in the plant.

Shut-off valves

We recommend installing a shut-off valve both in the flow pipe and the return flow pipe.

Insulation

Regulators and the pipeline can be insulated to reduce heat energy transfer.

Refer to the instructions in the 'Installation' section.

Design and principle of operation

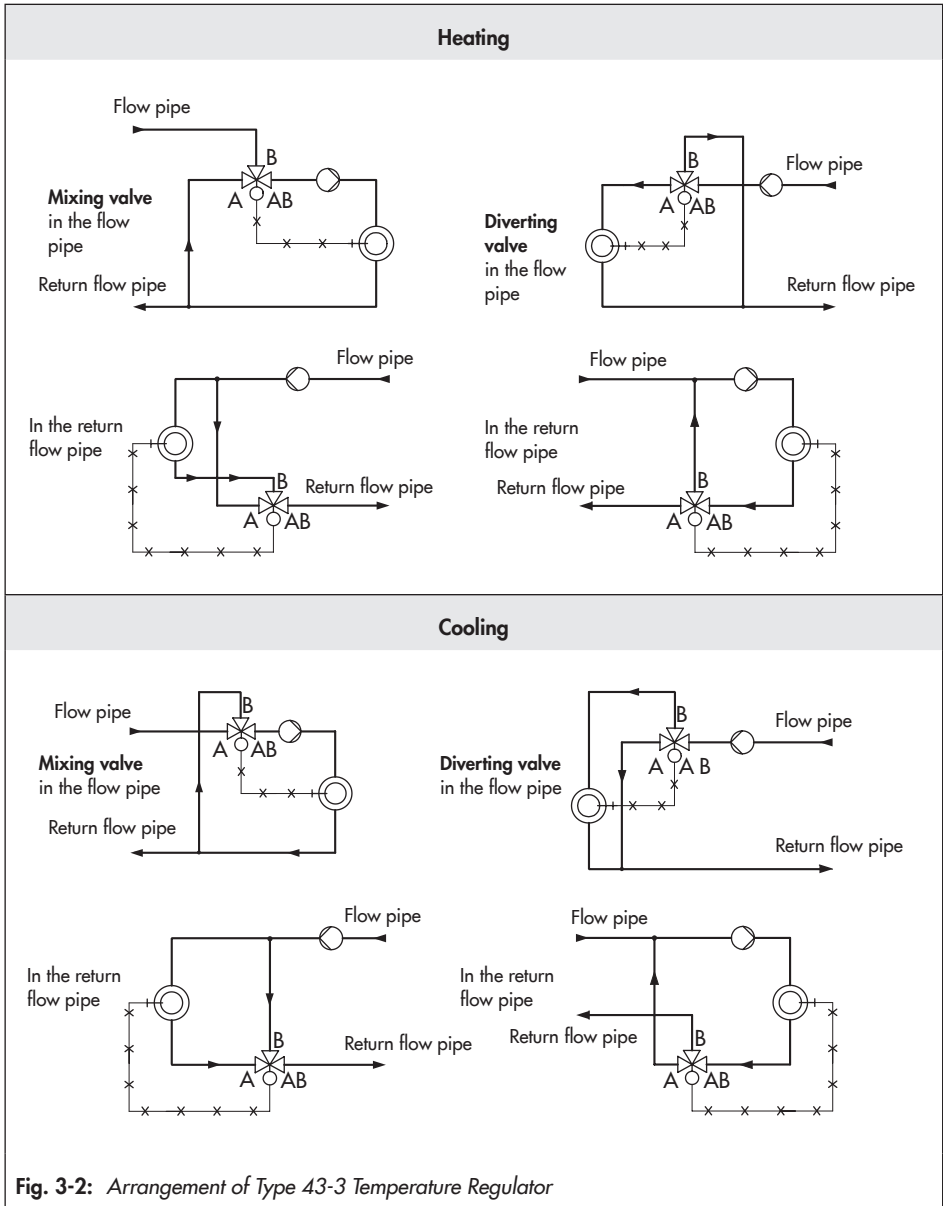

3.2 Technical data

The regulator nameplate provides information on the regulator version (see the 'Markings on the device' section).

i Note

More information is available in Data Sheet
▶ T 2173.

Process medium and scope of application

Designed for mixing or diverting service in heating or cooling installations The Type 43-3 Temperature Regulator is designed to maintain the temperature at the control thermostat sensor to the adjusted set point.

- Medium: **water**
- Max. temperature up to **150 °C**
- Temperature set points **from 0 to 150 °C**
- Valve sizes **G ½ to 1 · DN 15 to 50**
- **PN 25**



Testing according to DIN EN 14597

The **Type 43-3** Temperature Regulator combined with the **Type 2439** Safety Temperature Limiter or the **Type 2403** Safety Temperature Monitor is tested according to DIN. The registration number is available on request.

EC type examination

The DVGW type examination certificate is included in the 'Certificates' section.

Noise emissions

SAMSON is unable to make general statements about noise emissions. The noise emissions depend on the regulator version, plant facilities, process medium and operating conditions.

Temperature range

Depending on how the Type 43-3 Regulator is configured, it can be used up to max. 150 °C. The minimum temperature is limited by the seal material used in the regulator (see Table 3-1).

Dimensions and weights

Table 3-3 provides a summary of the dimensions and weights. The lengths and heights in the dimensional drawings are shown on page 3-8.

Design and principle of operation

Table 3-1: Technical data · All pressures in bar (gauge)

Type 2433 Three-way Valve											
Connection		Female thread			Male thread						
Connection size		G	½	¾	1	–					
Valve size		DN	–			15	20	25	32	40	50
Medium		Water									
K _{VS} coefficient		4	6.3	8	4	6.3	8	10	12.5	16	
Pressure rating		PN 25									
Max. perm. differential pressure Δp in bar											
Mixing valve	Δp when p in B > p in A	4.4	2.6	1.8	4.4	2.6	1.8	0.9	0.6	0.6	
	Δp when p in A > p in B	4.4	2.6	1.8	4.4	2.6	1.8	0.9	0.6	0.6	
Diverting valve	Δp when AB to A or B	4.4	2.6	1.8	4.4	2.6	1.8	0.9	0.6	0.6	
Max. permissible valve temperature		150 °C									
Type 2430 Control Thermostat											
Set point range (continuously adjustable)		0 to 35 °C, 25 to 70 °C, 40 to 100 °C, 50 to 120 °C or 70 to 150 °C									
Capillary tube		2 m (5 m as special version)									
Max. perm. excess temperature at sensor		50 °C above the adjusted set point									
Max. permissible ambient temperature		80 °C									
Permissible pressure at sensor/thermowell		PN 25/PN 40									
Max. perm. temperature range of medium		0 to +150 °C (with separating piece: –15 to +150 °C)									

Table 3-2: Materials · Material numbers according to DIN EN

Type 2433 Three-way Valve		
Body, seat	Red brass (RG5) CC499K	
Plug	Brass, resistant to dezincification, CW617N (CuZn40) with EPDM soft seal	
Valve spring	Stainless steel 1.4310	
Type 2430 Control Thermostat		
Set point adjuster	PTFE, glass fiber reinforced	
Temperature sensor	Capillary tube	Copper
	Thermowell	Copper or stainless steel 1.4310

Table 3-3: Dimensions in mm and weights

Conne- ction	G	½	¾	1	–		
Valve size	DN	15	20	25	32	40	50
Pipe Ø d		21.3	26.9	33.7	42.4	48.3	60.3
Thread size R		G ¾	G 1	G 1¼	G 1¾	G 2	G 2½
AF		30	36	46	59	65	82
L		65	70	75	100	110	130
L1		65	75	90	–		
H1		40	40	40	65	70	75
Weight ¹⁾ kg (approx.)		1.5	1.6	1.7	2.7	2.8	3.7
Connection nuts with welding ends, threaded ends or flanges							
H5		40			60	65	
Connection nuts with welding ends							
L2		210	234	244	268	294	330
H2		112	122	124	144	157	165
Weight ¹⁾ kg (approx.)		2	2.3	2.5	3.9	4.2	5.5
Connection nuts with threaded ends (male thread)							
Male thread A		G ½	G ¾	G 1	G 1¼	G 1½	G 2
L3		129	144	159	192	206	228
H3		72	77	82	100	108	114
Weight ¹⁾ kg (approx.)		2	2.3	2.5	3.9	4.2	5.5
Connection nuts with flanges (PN 16/25)							
L4		130	150	160	180	200	230
H4		70	80	85	100	105	120
Weight ¹⁾ kg (approx.)		4.1	5.3	6.3	8.7	10.2	13

¹⁾ Weights for version with bulb sensor and thermowell · Version without thermowell: minus 0.2 kg

Design and principle of operation

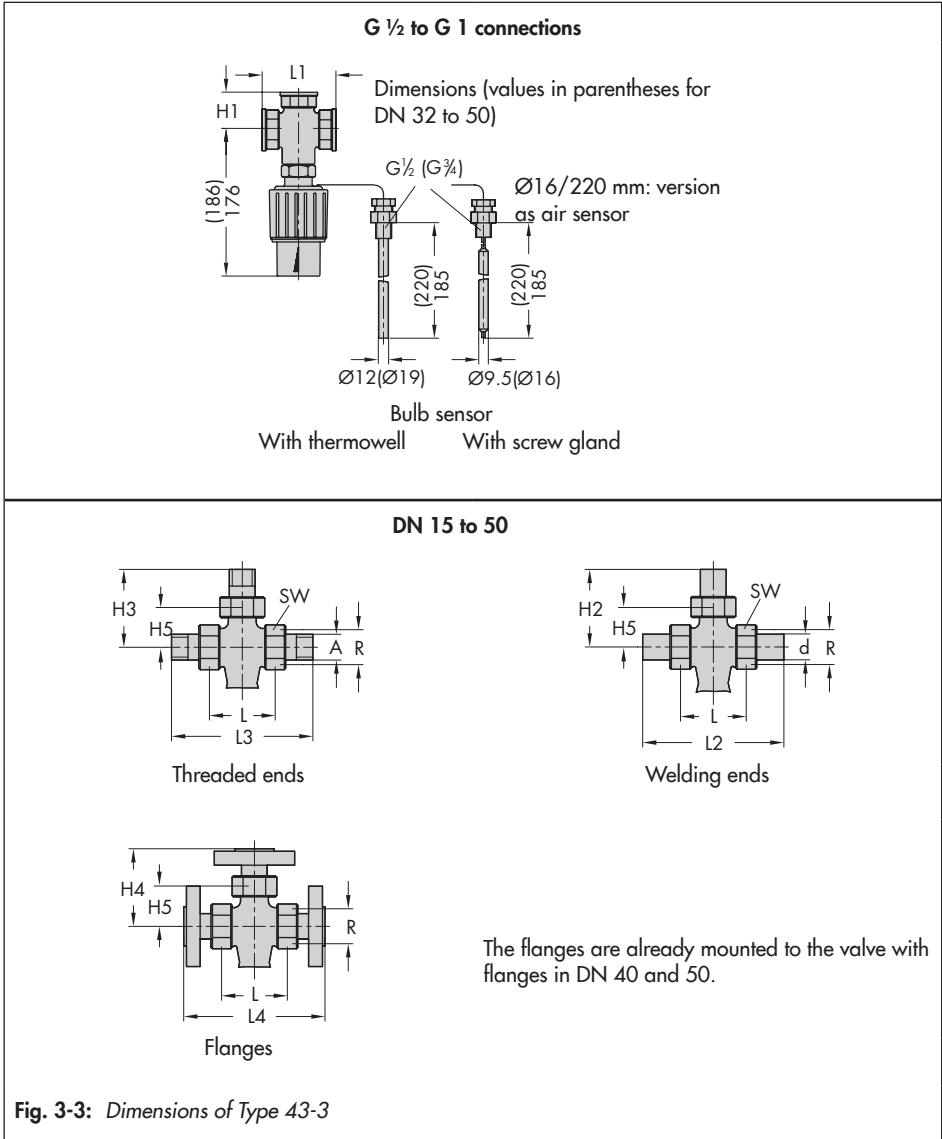

4 Shipment and on-site transport

The work described in this section is to be performed only by personnel appropriately qualified to carry out such tasks.

4.1 Accepting the delivered goods

After receiving the shipment, proceed as follows:

1. Check the scope of delivery. Check that the specifications on the nameplate and on the regulator itself match the specifications in the delivery note. See the 'Markings on the device' section for nameplate details.
2. Check the shipment for transportation damage. Report any damage to SAMSON and the forwarding agent (refer to delivery note).
3. Determine the weight and dimensions of the units to be lifted and transported in order to select the appropriate lifting equipment and lifting accessories. Refer to the transport documents and the 'Design and principle of operation' section.

4.2 Removing the packaging from the regulator

The components (valve, control thermostat and, if applicable, thermowell) of the regulator are delivered separately.

- Do not open or remove the packaging until immediately before lifting to install the regulator into the pipeline.
- Leave the regulator in its transport container or on the pallet to transport it on site.
- Dispose and recycle the packaging in accordance with the local regulations.

4.3 Transporting and lifting the regulator

Due to the low service weight, lifting equipment is not required to lift and transport the regulator (e.g. to install it into the pipeline).

- Leave the regulator in its transport container or on the pallet to transport it.
- Observe the transport instructions.

Transport instructions

- Protect the regulator against external influences (e.g. impact).
- Do not damage the corrosion protection (paint, surface coatings). Repair any damage immediately.
- Protect the regulator against moisture and dirt.
- The permissible ambient temperature of standard regulators is -20 to $+80$ °C.

4.4 Storing the regulator

NOTICE

Risk of regulator damage due to improper storage.

- Observe the storage instructions.
- Avoid long storage times.
- Contact SAMSON in case of different storage conditions or longer storage times.

Storage instructions

- Protect the regulator against external influences (e.g. impact).
- Secure the regulator in the stored position against slipping or tipping over.
- Do not damage the corrosion protection (paint, surface coatings). Repair any damage immediately.
- Protect the regulator against moisture and dirt. Store it at a relative humidity of less than 75 %. In damp spaces, prevent condensation. If necessary, use a drying agent or heating.
- Make sure that the ambient air is free of acids or other corrosive media.
- The permissible storage temperature of standard regulators is -20 to +65 °C.
- Do not place any objects on the regulator.

Note

We recommend to regularly check the regulator and the prevailing storage conditions during long storage periods.

Special storage instructions for elastomers

Elastomer, e.g. O-rings

- We recommend a storage temperature of 15 °C for elastomers.
- Store elastomers away from lubricants, chemicals, solutions and fuels.

Tip

SAMSON's After-sales Service can provide more detailed storage instructions on request.

5 Installation

The work described in this section is to be performed only by personnel appropriately qualified to carry out such tasks.

Valve and control thermostat can be assembled before or after the valve has been installed in the pipeline. We recommend first installing the valve without the control thermostat into the pipeline.

5.1 Installation conditions

Work position

The work position for the regulator is the front view onto all operating controls on the regulator (including any additional fittings) seen from the position of operating personnel.

Plant operators must ensure that, after installation of the device, the operating personnel can perform all necessary work safely and easily access the device from the work position.

Pipeline routing

The inlet and outlet lengths vary depending on several variables and process conditions and are intended as recommendations. Contact SAMSON if the lengths are significantly shorter than the recommended lengths.

To ensure that the regulator functions properly, proceed as follows:

- Make sure that the inlet and outlet flows of the plant are correctly assigned to ports A, B and AB according to Fig. 5-2.

- Install the regulator free of stress and with the least amount of vibrations as possible. Read information under "Mounting position" and "Temperature sensor" in this section.
- Install the regulator allowing sufficient space to remove the control thermostat and valve or to perform service work on them.

Mounting position

To ensure that the regulator functions properly, proceed as follows:

- The regulator can be mounted in any position when the medium temperature is up to 110 °C.
- At medium temperatures above 110 °C, install the regulator with the control thermostat suspended downward in horizontal pipelines (see Fig. 5-1).
- Make sure the direction of flow matches the direction indicated by the arrow on the valve body.
- Contact SAMSON if the mounting position is not as specified above.

NOTICE

Damage due to freezing.

Protect the regulator from icing up when controlling media that can freeze. Unless the regulator is installed in locations where no frost occurs, remove the regulator from the pipeline when the plant is shut down.

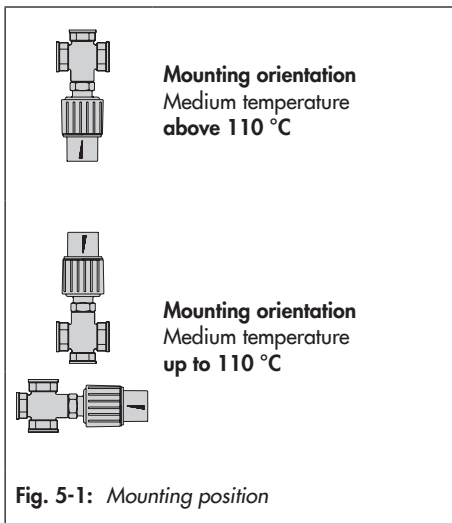

Temperature sensor

→ See Fig. 5-2

NOTICE

Galvanic corrosion due to incorrectly selected materials of the mounting parts.

On installing the sensor or thermowell, only combine the same kind of materials (e.g. stainless steel with stainless steel or copper together with other copper materials).

The temperature sensor, even together with a thermowell, can be installed in any position as required. However, make sure its entire length is immersed in the process medium to be controlled. It must be installed in a location where overheating or considerable idling times cannot occur.

Note

If the sensor is to be used with a thermowell, only use original SAMSON thermowells.

Weld a welding socket with G 1/2 or G 3/4 female thread (to match the screw gland) at the place of installation.

→ Seal the screw gland of the sensor.

Installation with thermowell

When a thermowell is used, a welding socket with G 1 female thread must be used.

1. Seal the thermowell into the welding socket.
2. Insert the sensor and tighten it with the clamping screw.

Note

For temperature regulators with safety temperature limiter (TR/STL), install the sensor of the limiter near the sensor of the regulator.

Dynamic behavior of Type 2430 Control Thermostat

The dynamics of the regulator are mainly determined by the response of the sensor with its characteristic time constant. Table 5-1 shows the dynamic behavior of the

Type 2430 Control Thermostat measured in water.

Capillary tube

Carefully run the capillary tube without bending or twisting it. Avoid locations with considerable ambient temperature fluctuations along the entire length of the tube.

i Note

Do not damage or shorten the capillary tube. Roll up any capillary tube that is not used. The smallest permissible bending radius is 50 mm.

Support and suspension

i Note

The plant engineering company is responsible for selecting and implementing a suitable support or suspension of the installed regulator and the pipeline.

Depending on the regulator version and mounting position, the regulator and pipeline must be supported or suspended.

! NOTICE

Do not attach supports directly to the regulator.

5.2 Preparation for installation

Before mounting, make sure the following conditions are met:

- The regulator is clean.
- The regulator is not damaged.
- Install a strainer upstream of the regulator in the flow pipe.
- The regulator data on the nameplate (type designation, valve size, material, pressure rating and temperature range) match the plant conditions (size and pressure rating of the pipeline, medium temperature etc.). See the 'Markings on the device' section for nameplate details.
- The requested or required additional fittings have been installed or prepared as necessary before installing the valve and control thermostat (see the 'Design and principle of operation' section).

Proceed as follows:

- ➔ Lay out the necessary material and tools to have them ready during installation work.
- ➔ Flush the pipeline **before** installing the regulator.
The plant operator is responsible for cleaning the pipelines in the plant.
- ➔ Check any mounted thermometers to make sure they function properly.

i Note

The plant operator is responsible for cleaning the pipelines in the plant.

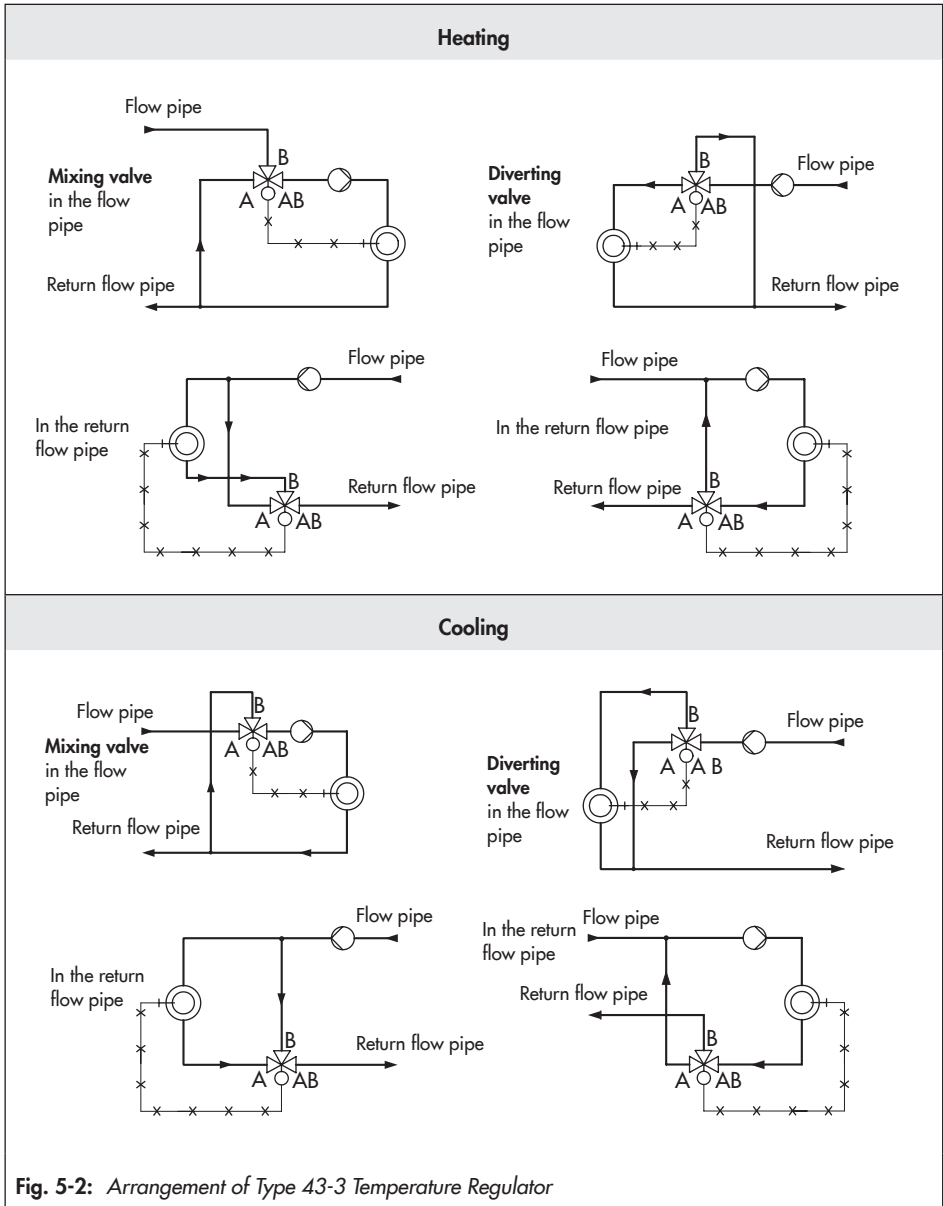

Table 5-1: Dynamic behavior of Type 2430 Control Thermostat (adsorption principle)

Type 2430	Sensor Ø	Time constant [s]	
		Without thermowell	With thermowell
Adsorption principle	9.5 mm	15	40
	16 mm	30	80
	Air sensor	8	– 1)

1) Thermowell not possible

5.3 Installation

The components (valve, control thermostat and, if applicable, thermowell) of the regulator are delivered separately. The activities listed below are necessary for installation and before start-up of the regulator.

ⓘ NOTICE

Risk of regulator damage due to excessively high or low tightening torques.

Observe the specified torques when tightening regulator components. Excessive tightening torques lead to parts wearing out more quickly. Parts that are too loose may cause leakage.

→ Observe the specified tightening torques (see 'Tightening torques' in Annex).

ⓘ NOTICE

Risk of regulator damage due to the use of unsuitable tools.

→ Only use tools approved by SAMSON (see 'Tools' in Annex).

ⓘ NOTICE

Risk of regulator damage due to the use of unsuitable lubricants.

→ Only use lubricants approved by SAMSON (see 'Lubricants' in Annex).

5.3.1 Installing the regulator

1. Close the shut-off valves in the flow pipe and return flow pipe while the regulator is being installed.
2. Observe the flow direction through the valve. The arrow on the valve indicates the direction of flow.
3. Make sure that the correct gaskets are used.
4. Bolt the pipe to the valve free of stress.
5. Slowly open the shut-off valves in the pipeline after the regulator has been installed.

5.3.2 Cleaning the pipeline

We recommend additionally flushing the pipeline without the installed regulator before start-up. In this case, install a suitable length of pipe into the pipeline in place of the regulator.

- Observe the mesh size of the upstream strainer for the maximum particle size. Use strainers to suit the process medium.
- Check the strainer for dirt each time the pipeline is flushed and clean it, if necessary.

5.4 Testing the regulator

⚠ DANGER

Risk of bursting due to incorrect opening of pressurized equipment or components.

Regulators and pipelines are pressure equipment that may burst when handled incorrectly. Flying projectile fragments or the release of process medium under pressure can cause serious injury or even death.

Before working on the regulator:

- *Depressurize all plant sections concerned and the regulator.*
 - *Drain the process medium from all the plant sections concerned as well as the valve.*
-

⚠ DANGER

Risk of personal injury due to process medium escaping.

- *Do not start up the regulator until all parts have been mounted.*
-

⚠ WARNING

Risk of hearing loss or deafness due to loud noise.

Noise emission (e.g. cavitation or flashing) may occur during operation caused by the process medium and the operating conditions.

- *Wear hearing protection when working near the valve. Follow the instructions given by the plant operator.*
-

⚠ WARNING

Risk of burn injuries due to hot or very cold components and pipelines.

Depending on the process medium, the regulator and pipelines may get very hot or cold and cause burn injuries.

→ *Wear protective clothing and safety gloves.*

SAMSON regulators are delivered ready for use. To test the regulator functioning before start-up or putting back the regulator into operation, perform the following tests:

5.4.1 Leakage

The plant operator is responsible for performing the leak test and selecting the test method. The leak test must comply with the requirements of the national and international standards that apply at the site of installation.

**Tip**

SAMSON's After-sales Service can support you to plan and perform a leak test for your plant.

1. Slowly open the shut-off valve installed upstream of the regulator.
2. Apply the required test pressure.
3. Check the regulator for leakage to the atmosphere.
4. Check the screw gland of the sensor or thermowell for leakage.
5. Depressurize the pipeline section and regulator.
6. Rework any parts that leak and repeat the leak test.

5.4.2 Pressure test

i Note

The plant operator is responsible for performing the pressure test. SAMSON's After-sales Service can support you to plan and perform a pressure test for your plant.

! NOTICE

Risk of regulator damage due to a sudden pressure increase and resulting high flow velocities.

→ *Slowly open the shut-off valves.*

During the pressure test, make sure the following conditions are met:

→ Do not allow the pressure to exceed the 1.5 times the pressure rating of the valve body.

5.5 Insulation

To insulate cold systems, we recommend first filling the plant and carefully rinsing it. The regulator must not yet be insulated at this stage.

! NOTICE

Risk of regulator damage due to incorrect insulation.

→ *Only insulate the regulator up to the control thermostat for medium temperatures below 0 °C or above 80 °C.*

1. Start up the plant and adjust the set point (see the 'Start-up' section).
2. Shut down the plant again and let it heat up until the condensation water has dried off.
3. Insulate the regulator and pipes conveying the process medium using insulation material with a water vapor barrier. If an external control line is to be routed through the insulation, special care must be taken with the sealing since slight changes in shape may occur. The insulation thickness depends on the medium temperature and the ambient conditions. 50 mm is a typical thickness.

6 Start-up

The work described in this section is to be performed only by personnel appropriately qualified to carry out such tasks.

⚠ DANGER

Risk of personal injury due to process medium escaping.

- Do not start up the regulator until all parts have been mounted.

⚠ WARNING

Risk of burn injuries due to hot or cold components and pipeline.

Regulator components and the pipeline may become very hot or cold. Risk of burn injuries.

- Allow components and pipelines to cool down or warm up to the ambient temperature.
- Wear protective clothing and safety gloves.

⚠ WARNING

Risk of hearing loss or deafness due to loud noise.

Noise emission (e.g. cavitation or flashing) may occur during operation caused by the process medium and the operating conditions.

- Wear hearing protection when working near the valve. Follow the instructions given by the plant operator.

ⓘ NOTICE

Risk of overheating due to excessive ambient temperatures or insufficient heat dissipation when components are insulated.

- Do not include the regulator in the insulation of the pipeline.

ⓘ NOTICE

Risk of impaired functioning of the regulator and leakage at the joint due to installation under tension.

- Bolt the regulator to the pipeline free of stress.
- If necessary, support the pipelines near the connections.
- Do not attach supports directly to the valve or control thermostat.

Before start-up or putting the device back into service, make sure the following conditions are met:

- The regulator is properly installed into the pipeline (see the 'Installation' section).
- The leak and function tests have been completed successfully (see the 'Testing the regulator' section).
- The prevailing conditions in the plant section concerned meet the regulator sizing requirements (see information under 'Intended use' in the 'Safety instructions and measures' section).

6.1 Start-up and putting the device back into operation

1. Depending on the field of application, allow the regulator to cool down or warm up to reach ambient temperature before start up.
2. Slowly open the shut-off valves in the pipeline. Slowly opening these valves prevents a sudden surge in pressure and high flow velocities which can damage the valve.
3. Check the regulator to ensure it functions properly.

6.2 Starting up the plant

1. Open the shut-off valve slowly in the flow pipe first. Afterwards, open all the valves on the consumer side (downstream of the regulator).
2. Fill the plant **slowly** with the process medium. Avoid pressure surges.
3. Make sure that the pressure rises simultaneously upstream and downstream of the regulator.
4. To start up the regulator, open the downstream side **slowly**.
5. Check the adjusted temperature set point at the thermometer installed near the temperature sensor.

7 Operation

Immediately after completing start-up or placing the regulator back into service (see the 'Start-up' section), the regulator is ready for use.

⚠ WARNING

Risk of burn injuries due to hot or cold components and pipeline.

Regulator components and the pipeline may become very hot or cold. Risk of burn injuries.

- *Allow components and pipelines to cool down or warm up to the ambient temperature.*
- *Wear protective clothing and safety gloves.*

⚠ WARNING

Risk of hearing loss or deafness due to loud noise.

Noise emission (e.g. cavitation or flashing) may occur during operation caused by the process medium and the operating conditions.

- *Wear hearing protection when working near the valve. Follow the instructions given by the plant operator.*

7.1 Adjusting the temperature set point

Adjust the required set point by turning the set point adjuster (43) by hand. The adjustment diagrams (see Fig. 7-3) can be used as a guide to find the first approximate value.

Set point adjuster

- Turn the set point adjuster clockwise (↻) to increase the temperature set point.
- Turn the set point adjuster counterclockwise (↺) to reduce the temperature set point.

The thermometer (4) installed on the downstream side on site allows the adjusted set point to be monitored.

i Note

Higher set point temperatures can be adjusted in increments as required. However, to lower the set point temperature, proceed in steps of 10 to 20 °C. When doing so, wait for the process medium to cool down before continuing. Watch the thermometer.

Type 43-3

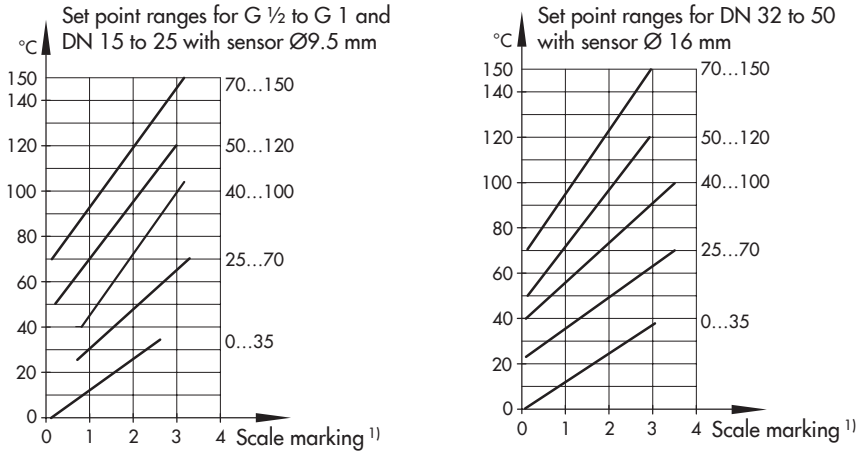

Table 7-2: Set point ranges

Set point range	Set point change ΔT per turn	Sensor \varnothing
0 to 35 °C	2.5 °C	9.5 mm
	2 °C	16 mm
25 to 70 °C	3 °C	9.5 mm
	2 °C	16 mm
40 to 100 °C	4 °C	9.5 mm
	3 °C	16 mm
50 to 120 °C	4 °C	9.5 mm
	4.5 °C	16 mm
70 to 150 °C	4.5 °C	9.5 mm
	5 °C	16 mm

Fig. 7-3: Adjustment diagrams

¹⁾ On the thermostat head

8 Malfunctions

8.1 Troubleshooting

8.1.1 Temperature regulators for heating applications

Malfunction	Possible reasons	Recommended action
Temperature at the sensor exceeds the set point.	Seat and plug are worn or leak.	<ul style="list-style-type: none"> → Clean the seat and plug. → Contact SAMSON's After-sales Service.
	Foreign particles blocking the plug	<ul style="list-style-type: none"> → Remove foreign particles. → Contact SAMSON's After-sales Service.
	Sensor installed in the wrong location.	→ Change the mounting position.
	Sensor installed incorrectly.	<ul style="list-style-type: none"> → Immerse the temperature sensor with its entire immersion depth in the process medium. → Avoid an installation site where idle times or heat buildup can occur.
	Regulator or K_{VS}/C_V coefficient too large	<ul style="list-style-type: none"> → Check the sizing. → Install a suitable valve. → Contact SAMSON's After-sales Service.
	Control thermostat defective Mixing valve: port A closed Diverging valve: port B closed.	→ Replace the control thermostat.
Temperature at the sensor fluctuates.	Regulator or K_{VS}/C_V coefficient too large	<ul style="list-style-type: none"> → Check the sizing. → Install a suitable valve. → Contact SAMSON's After-sales Service.
	Sensor installed in the wrong location.	→ Change the mounting position.
	Sensor installed incorrectly.	<ul style="list-style-type: none"> → Immerse the temperature sensor with its entire immersion depth in the process medium. → Avoid an installation site where idle times or heat buildup can occur.
Slow control response	Time constant is too large for the control loop.	<ul style="list-style-type: none"> → Fill the thermowell with thermal paste or remove the thermowell. → Use a sensor with smaller time constant (e.g. vapor pressure thermostat).
	Sensor installed incorrectly.	<ul style="list-style-type: none"> → Immerse the temperature sensor with its entire immersion depth in the process medium. → Avoid an installation site where idle times or heat buildup can occur.

Malfunctions

Malfunction	Possible reasons	Recommended action
Temperature at the sensor does not reach the set point.	Seat and plug are worn or leak.	<ul style="list-style-type: none"> → Clean the seat and plug. → Contact SAMSON's After-sales Service.
	Valve installed against the flow.	<ul style="list-style-type: none"> → Install the valve so that the direction of flow matches the direction indicated by the arrow on the body.
	Incorrectly installed valve	<ul style="list-style-type: none"> → During installation, observe the correct direction of flow and arrangement of the ports A/B/AB.
	Strainer blocked.	<ul style="list-style-type: none"> → Clean the strainer.
	Regulator or K_{VS}/C_v coefficient too small	<ul style="list-style-type: none"> → Check the sizing. → Install a suitable valve. → Contact SAMSON's After-sales Service.
	A safety device (e.g. STL or STM) has been triggered. Mixing valve: port B closed Diverting valve: port A closed	<ul style="list-style-type: none"> → Check plant. Unlock safety device (where necessary).
	Insufficient heating energy available	<ul style="list-style-type: none"> → Draw up an energy balance.
	Foreign particles blocking the plug	<ul style="list-style-type: none"> → Remove foreign particles. → Contact SAMSON's After-sales Service.
	Sensor installed in the wrong location.	<ul style="list-style-type: none"> → Change the mounting position.
	Sensor installed incorrectly.	<ul style="list-style-type: none"> → Immerse the temperature sensor with its entire immersion depth in the process medium. → Avoid an installation site where idle times or heat buildup can occur.
Jerky control response	Increased friction, e.g. due to foreign particles between seat and plug.	<ul style="list-style-type: none"> → Remove foreign particles. → Contact SAMSON's After-sales Service.
Loud flow-induced noise	High flow velocity, cavitation.	<ul style="list-style-type: none"> → Check the sizing. → Install larger regulator, if necessary.
Leak between control thermostat and valve	Valve seal defective	<ul style="list-style-type: none"> → Contact SAMSON's After-sales Service.

Note

Contact SAMSON's After-sales Service for malfunctions not listed in the table.

8.1.2 Temperature regulators for cooling applications

Malfunction	Possible reasons	Recommended action
Temperature at the sensor exceeds the set point.	Seat and plug are worn or leak.	<ul style="list-style-type: none"> → Clean the seat and plug. → Contact SAMSON's After-sales Service.
	Foreign particles blocking the plug	<ul style="list-style-type: none"> → Remove foreign particles. → Contact SAMSON's After-sales Service.
	Sensor installed in the wrong location.	→ Change the mounting position.
	Sensor installed incorrectly.	<ul style="list-style-type: none"> → Immerse the temperature sensor with its entire immersion depth in the process medium. → Avoid an installation site where idle times or heat buildup can occur.
	Regulator or K_{VS}/C_V coefficient too small	<ul style="list-style-type: none"> → Check the sizing. → Install a suitable valve. → Contact SAMSON's After-sales Service.
	Incorrectly installed valve	→ During installation, observe the correct direction of flow and arrangement of the ports A/B/AB.
	Insufficient cooling energy available	→ Draw up an energy balance.
	Control thermostat defective Mixing valve: port A closed Diverting valve: port B closed.	→ Replace the control thermostat.
	Strainer blocked.	→ Clean the strainer.
Temperature at the sensor fluctuates.	Regulator or K_{VS}/C_V coefficient too large	<ul style="list-style-type: none"> → Check the sizing. → Install a suitable valve. → Contact SAMSON's After-sales Service.
	Sensor installed in the wrong location.	→ Change the mounting position.
	Sensor installed incorrectly.	<ul style="list-style-type: none"> → Immerse the temperature sensor with its entire immersion depth in the process medium. → Avoid an installation site where idle times or heat buildup can occur.
Slow control response	Time constant is too large for the control loop.	<ul style="list-style-type: none"> → Fill the thermowell with thermal paste or remove the thermowell. → Use a sensor with smaller time constant (e.g. vapor pressure thermostat).
	Sensor installed incorrectly.	<ul style="list-style-type: none"> → Immerse the temperature sensor with its entire immersion depth in the process medium. → Avoid an installation site where idle times or heat buildup can occur.

Malfunctions

Malfunction	Possible reasons	Recommended action
Temperature at the sensor does not reach the set point.	Seat and plug are worn or leak.	<ul style="list-style-type: none"> → Clean the seat and plug. → Contact SAMSON's After-sales Service.
	Regulator or K_{VS}/C_v coefficient too large	<ul style="list-style-type: none"> → Check the sizing. → Install a suitable valve. → Contact SAMSON's After-sales Service.
	A safety device (e.g. STL or STM) has been triggered. Mixing valve: port B closed Diverting valve: port A closed	<ul style="list-style-type: none"> → Check plant. Unlock safety device (where necessary).
	Foreign particles blocking the plug	<ul style="list-style-type: none"> → Remove foreign particles. → Contact SAMSON's After-sales Service.
	Sensor installed in the wrong location.	<ul style="list-style-type: none"> → Change the mounting position.
	Sensor installed incorrectly.	<ul style="list-style-type: none"> → Immerse the temperature sensor with its entire immersion depth in the process medium. → Avoid an installation site where idle times or heat buildup can occur.
Jerky control response	Increased friction, e.g. due to foreign particles between seat and plug.	<ul style="list-style-type: none"> → Remove foreign particles. → Contact SAMSON's After-sales Service.
Loud flow-induced noise	High flow velocity, cavitation.	<ul style="list-style-type: none"> → Check the sizing. → Install larger regulator, if necessary.
Leak between control thermostat and valve	Valve seal defective	<ul style="list-style-type: none"> → Contact SAMSON's After-sales Service.

i Note

Contact SAMSON's After-sales Service for malfunctions not listed in the table.

The malfunctions listed in section 8.1 are caused by mechanical faults and incorrect regulator sizing. In the simplest case, the functioning can be restored following the recommended action. Special tools may be required to rectify the fault.

Exceptional operating and installation conditions may lead to changed situations that may affect the control response and lead to malfunctions. For troubleshooting, the conditions, such as installation, process medium, temperature and pressure conditions, must be taken into account.

**Tip**

SAMSON's After-sales Service can support you in drawing up an inspection and test plan for your plant.

8.2 Emergency action

Plant operators are responsible for emergency action to be taken in the plant.

We recommend removing the regulator from the pipeline before repairing it.

In the event of a regulator malfunction:

1. Close the shut-off valves in the flow and return flow pipes to stop the process medium from flowing through the regulator.
2. Perform troubleshooting (see section 8.1).
3. Rectify those malfunctions that can be remedied based on the instructions provided here. Contact SAMSON's After-sales Service in all other cases.

Putting the device back into operation after a malfunction

See the 'Start-up' section.

9 Servicing

The regulator does not require much maintenance. Nevertheless, it is subject to natural wear, particularly at the seat, plug and control thermostat. Depending on the operating conditions, check the regulator at regular intervals to avoid possible malfunctions. Plant operators are responsible for drawing up an inspection and test plan. Details on faults and how to remedy them can be found in the 'Malfunctions' section.

The work described in this section is to be performed only by personnel appropriately qualified to carry out such tasks.

We recommend removing the regulator from the pipeline before performing any maintenance or service work.

⚠ WARNING

Risk of burn injuries due to hot or cold components and pipeline.

Regulator components and the pipeline may become very hot or cold. Risk of burn injuries.

- ➔ *Allow components and pipelines to cool down or warm up to the ambient temperature.*
 - ➔ *Wear protective clothing and safety gloves.*
-

⚠ WARNING

Risk of personal injury due to residual process medium in the regulator.

While working on the regulator, residual process medium can escape and, depending on its properties, may lead to personal injury, e.g. (chemical) burns.

- ➔ *Wear protective clothing, safety gloves and eye protection.*
-

ⓘ NOTICE

Risk of regulator damage due to excessively high or low tightening torques.

Observe the specified torques when tightening regulator components. Excessive tightening torques lead to parts wearing out more quickly. Parts that are too loose may cause leakage.

- ➔ *Observe the specified tightening torques (see 'Tightening torques' in Annex).*
-

NOTICE

Risk of regulator damage due to the use of unsuitable tools.

→ Only use tools approved by SAMSON (see 'Tools' in Annex).

NOTICE

Risk of regulator damage due to the use of unsuitable lubricants.

→ Only use lubricants approved by SAMSON (see 'Lubricants' in Annex).

Note

The regulator was checked by SAMSON before it left the factory.

- Certain test results certified by SAMSON lose their validity when the regulator is opened. Such testing includes seat leakage and leak tests.
- The product warranty becomes void if service or repair work not described in these instructions is performed without prior agreement by SAMSON's After-sales Service.
- Only use original spare parts by SAMSON, which comply with the original specifications.

Tip

SAMSON's After-sales Service can support you in drawing up an inspection and test plan for your plant.

9.1 Preparing the valve for service work

1. Lay out the necessary material and tools to have them ready for the service work.
2. Put the regulator out of operation (see the 'Decommissioning' section).

Tip

We recommend removing the regulator from the pipeline before performing any service work (see the 'Removing the regulator from the pipeline' section).

The following service work can be performed after preparation is completed:

- Clean the seat and plug (see section 9.4)

9.2 Installing the regulator after service work

- Put the regulator back into operation (see the 'Start-up' section). Make sure the requirements and conditions for start-up or putting the valve back into operation are met.

9.3 Service work

- Before performing any service work, preparations must be made to the regulator (see section 9.1).
- After all service work is completed, check the regulator before putting it back into operation (see 'Testing the regulator' in the 'Installation' section).

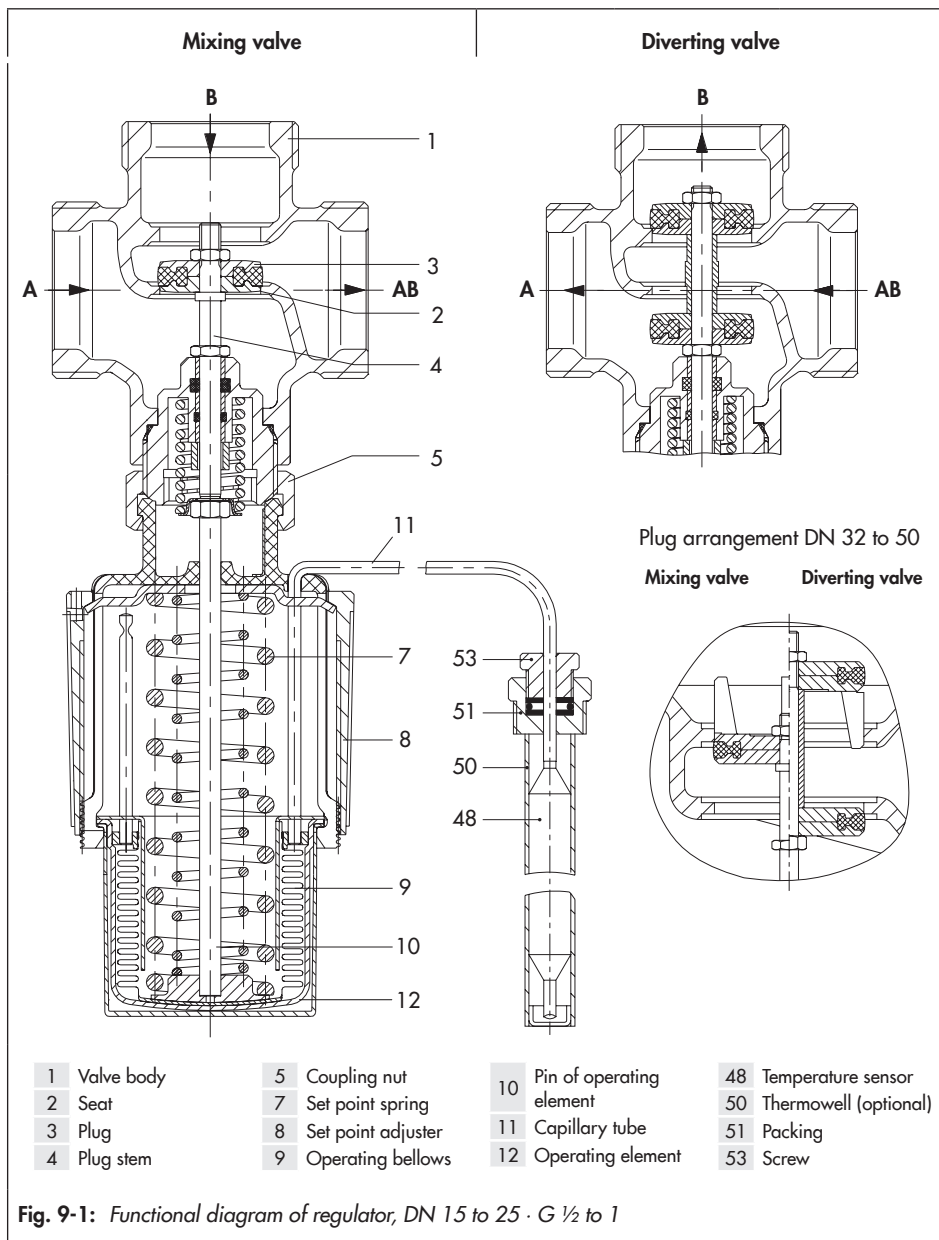

Fig. 9-1: Functional diagram of regulator, DN 15 to 25 · G ½ to 1

9.4 Cleaning the seat and plug

! NOTICE

Risk of regulator damage due to excessively high or low tightening torques.

Observe the specified torques when tightening regulator components. Excessive tightening torques lead to parts wearing out more quickly. Parts that are too loose may cause leakage.

Observe the specified tightening torques.

i Note

SAMSON's After-sales Service can support you concerning lubricant, tightening torques and tools approved by SAMSON.

Contact SAMSON's After-sales Service for more information on cleaning the seat and plug.

9.5 Ordering spare parts and operating supplies

Contact your nearest SAMSON subsidiary or SAMSON's After-sales Service for information on spare parts, lubricants and tools.

Spare parts

Contact SAMSON's After-sales Service for more information on spare parts.

Lubricants

Contact SAMSON's After-sales Service for more information on lubricants.

Tools

Contact SAMSON's After-sales Service for more information on tools.

10 Decommissioning

The work described in this section is to be performed only by personnel appropriately qualified to carry out such tasks.

⚠ DANGER

Risk of bursting due to incorrect opening of pressurized equipment or components.

Regulators and pipelines are pressure equipment that may burst when handled incorrectly. Flying projectile fragments or the release of process medium under pressure can cause serious injury or even death. Before working on the regulator:

- Depressurize all plant sections concerned and the regulator.
- Shut off an external control line.
- Drain the process medium from all the plant sections affected as well as the regulator.

⚠ WARNING

Risk of burn injuries due to hot or cold components and pipeline.

Regulator components and the pipeline may become very hot or cold. Risk of burn injuries.

- Allow components and pipelines to cool down or warm up to the ambient temperature.
- Wear protective clothing and safety gloves.

⚠ WARNING

Risk of personal injury due to pressurized components and process medium being discharged.

- Do not loosen the external control line while the valve is pressurized.

⚠ WARNING

Risk of hearing loss or deafness due to loud noise.

Noise emission (e.g. cavitation or flashing) may occur during operation caused by the process medium and the operating conditions.

- Wear hearing protection when working near the valve. Follow the instructions given by the plant operator.

⚠ WARNING

Risk of personal injury due to residual process medium in the regulator.

While working on the regulator, residual process medium can escape and, depending on its properties, may lead to personal injury, e.g. (chemical) burns.

- Wear protective clothing, safety gloves and eye protection.

Decommissioning

To decommission the regulator for service work or disassembly, proceed as follows:

1. Close the shut-off valves in the flow pipe and return flow pipe.
2. Close any shut-off valve installed on the downstream and upstream side of the sensor if a thermowell is not used.
3. Completely drain the pipelines and regulator.
4. Depressurize the plant.
5. If necessary, allow the pipeline and regulator components to cool down or warm up to the ambient temperature.

11 Removal

The work described in this section is to be performed only by personnel appropriately qualified to carry out such tasks.

⚠ WARNING

Risk of burn injuries due to hot or cold components and pipeline.

Regulator components and the pipeline may become very hot or cold. Risk of burn injuries.

- *Allow components and pipelines to cool down or warm up to the ambient temperature.*
- *Wear protective clothing and safety gloves.*

⚠ WARNING

Risk of personal injury due to residual process medium in the regulator.

While working on the regulator, residual process medium can escape and, depending on its properties, may lead to personal injury, e.g. (chemical) burns.

- *Wear protective clothing, safety gloves and eye protection.*

Before removing the valve, make sure the following conditions are met:

- The regulator is put out of operation (see the 'Decommissioning' section).

11.1 Removing the control thermostat

1. Pull the sensor out of the thermowell. In cases where a thermowell is not used, unscrew the screw gland and pull out the sensor.
2. Unscrew the control thermostat from the valve (width across flats 36).

11.2 Removing the valve from the pipeline

1. Support the valve to hold it in place when separated from the pipeline (see the 'Shipment and on-site transport' section).
2. Unbolt the pipe/flanged joint.
3. Remove the valve from the pipeline (see the 'Shipment and on-site transport' section).

12 Repairs

If the regulator does not function properly according to how it was originally sized or does not function at all, it is defective and must be repaired or exchanged.

! NOTICE

Risk of regulator damage due to incorrect service or repair work.

- ➔ Do not perform any repair work on your own.
- ➔ Contact SAMSON's After-sales Service for service and repair work.

12.1 Returning devices to SAMSON

Defective devices can be returned to SAMSON for repair.

Proceed as follows to return devices:

1. Exceptions apply concerning some special device models ► www.samsongroup.com > Service & Support > After-sales Service.
2. Send an e-mail ► retouren@samsongroup.com to register the return

shipment including the following information:

- Type
- Article no.
- Material number
- Original order
- Completed Declaration on Contamination, which can be downloaded from our website at ► www.samsongroup.com > Service & Support > After-sales Service.

After checking your registration, we will send you a return merchandise authorization (RMA).

3. Attach the RMA (together with the Declaration on Decontamination) to the outside of your shipment so that the documents are clearly visible.
4. Send the shipment to the address given on the RMA.

i Note

Further information on returned devices and how they are handled can be found at ► www.samsongroup.com > Service & Support > After-sales Service.

13 Disposal



SAMSON is a producer registered at the following European institution ► <https://www.ewrn.org/national-registers/national-registers>.
WEEE reg. no.:
DE 62194439/FR 025665

- Observe local, national and international refuse regulations.
- Do not dispose of components, lubricants and hazardous substances together with your other household waste.

i Note

We can provide you with a recycling passport according to PAS 1049 on request. Simply e-mail us at aftersaleservice@samsongroup.com giving details of your company address.

Tip

On request, we can appoint a service provider to dismantle and recycle the product as part of a distributor take-back scheme.

14 Certificates

The following certificates are included on the next pages:

- DVGW type examination certificate,
on page 14-2.
- Tested according to DIN EN 14597:
2015-02
on page 14-4.



CERT

DVGW type examination certificate

DVGW-Baumusterprüfzertifikat

DW-6340BN3862

Registration Number
Registriernummer

Field of Application <i>Anwendungsbereich</i>	products of water supply <i>Produkte der Wasserversorgung</i>
Owner of Certificate <i>Zertifikatinhaber</i>	Samson AG Weismüllerstraße 3, D-60314 Frankfurt am Main
Distributor <i>Vertreiber</i>	Samson AG Weismüllerstraße 3, D-60314 Frankfurt am Main
Product Category <i>Produktart</i>	valves for drinking water: thermostatic control valve (6340)
Product Description <i>Produktbezeichnung</i>	three-way valve (with control thermostat) for the distribution respectively supply of cold water in storage reservoir or thermal transmitter for making hot drinking water
Model <i>Modell</i>	Typ 43-3
Test Reports <i>Prüfberichte</i>	laboratory control test: from 07.03.2022 (TZW) type testing: TA 036/11 from 09.01.2012 (TZW) UBA-Guideline: K-340122-21-Kr/sg from 15.02.2021 (WHY)
Test Basis <i>Prüfgrundlagen</i>	DVGW 31-24/2-2007 (31.10.2002) UBA BWGL-Metalle (14.05.2020) UBA Übergangsregelung KTW-BWGL (10.07.2020) DVGW W 270 (01.11.2007)

Date of Expiry / File No. 20.12.2027 / 22-0460-WNV
Ablaufdatum / Aktenzeichen

28.09.2022 LE A-1/2
Date, Issued by, Sheet, Head of Certification Body
Datum, Bearbeiter, Blatt, Leiter der Zertifizierungsstelle



DVGW CERT GmbH
Zertifizierungsstelle
Josef-Wimmer-Str. 1-3
53123 Bonn
Tel. +49 228 91 88 - 888
Fax +49 228 91 88 - 993
www.dvgw-cert.com
info@dvgw-cert.com

A-2/2

DW-6340BN3862

Type Typ	Technical Data <i>Technische Daten</i>	Remarks <i>Bemerkungen</i>
Typ 43-3	pressure rating: PN 10 nominal diameter: DN 15	
Typ 43-3	pressure rating: PN 10 nominal diameter: DN 20	
Typ 43-3	pressure rating: PN 10 nominal diameter: DN 25	
Typ 43-3	pressure rating: PN 10 nominal diameter: DN 32	
Typ 43-3	pressure rating: PN 10 nominal diameter: DN 40	
Typ 43-3	pressure rating: PN 10 nominal diameter: DN 50	



ZERTIFIKAT

Zertifikatinhaber	SAMSON AG Weismüllerstr. 3 60314 Frankfurt DEUTSCHLAND
Produkt	Temperaturregel- und Begrenzungseinrichtungen für Wärmeerzeugungsanlagen
Typ, Modell	2430-0 (2750-0)
Prüfgrundlage(n)	DIN EN 14597:2015-02 Zertifizierungsprogramm Temperaturregel- und -begrenzungseinrichtungen für wärmeerzeugende Anlagen (2009-01)
Konformitätszeichen	
Registernummer	TR(TB)1054
Gültig bis	2023-12-31
Nutzungsrecht	Dieses Zertifikat berechtigt zum Führen des oben stehenden Konformitätszeichens in Verbindung mit der genannten Registernummer. Weitere Angaben siehe Anhang.



2019-09-27

Dipl.-W.-Ing. (FH) Sören Scholz
Leiter der Zertifizierungsstelle



ANHANG

Seite 1 von 1

Zertifikat	TR(TB)1054 von 2019-09-27
Technische Angaben	siehe technisches Datenblatt zur o. g. Registernummer unter www.dincertco.tuv.com Stellglieder: 2710, 2720, 2730, 2433
Prüflaboratorium/ Überwachungsstelle	TÜV Rheinland Industrie Service GmbH Am Grauen Stein 51105 Köln DEUTSCHLAND
Prüfbericht(e)	T95 2005 Z1 von 2006-09-27 T95 2008 T3 von 2008-12-10 T95 2014 V4 von 2014-09-29 968/FSP 1905.00/19 von 2019-06-27



15 Annex

15.1 Tightening torques

Table 15-1: *Tightening torque*

Component	Width across flats	Valve size	Tightening torque in Nm
Coupling nut (40)	SW 36	All	20

15.2 Tools

SAMSON's After-sales Service can support you concerning tools approved by SAMSON.

15.3 Lubricants

SAMSON's After-sales Service can support you concerning lubricants and sealants approved by SAMSON.

15.4 Spare parts and accessories

SAMSON's After-sales Service can support you concerning spare parts approved by SAMSON.

Table 15-2: *Accessories*

	DN 15	DN 20	DN 25	DN 32	DN 40	DN 50
Gasket (1 pc.)	8413-3000	8413-3001	8413-3002	8413-3003	8413-3004	8413-3005
	0430-3064 ¹⁾	0430-3065 ¹⁾	0430-3066 ¹⁾	0430-3067 ¹⁾	0430-3068 ¹⁾	0430-3069 ¹⁾
Three threaded ends for male thread connection	1400-6540	1400-6541	1400-6542	1400-6543	1400-6544	1400-6545
	1402-0628 ¹⁾	1402-0629 ¹⁾	1402-0630 ¹⁾	1402-0631 ¹⁾	1402-0632 ¹⁾	1402-0633 ¹⁾
Three welding ends for male thread connection	1400-6528	1400-6529	1400-6530	1400-6531	1400-6532	1400-6533
	1402-0622 ¹⁾	1402-0623 ¹⁾	1402-0624 ¹⁾	1402-0625 ¹⁾	1402-0626 ¹⁾	1402-0627 ¹⁾
Three screwed-on flanges for male thread connection	1400-6534	1400-6535	1400-6536	1400-6537	1400-6538	1400-6539
	1402-0640 ¹⁾	1402-0641 ¹⁾	1402-0642 ¹⁾	1402-0643 ¹⁾	1402-0644 ¹⁾	1402-0645 ¹⁾

¹⁾ With DVGW certification

15.5 After-sales service

Contact SAMSON's After-sales Service for support concerning service or repair work or when malfunctions or defects arise.

E-mail address

You can reach our after-sales service at aftersalesservice@samsongroup.com.

Addresses of SAMSON AG and its subsidiaries

The addresses of SAMSON, its subsidiaries, representatives and service facilities worldwide can be found on our website (▶ www.samsongroup.com) or in all SAMSON product catalogs.

Required specifications

Please submit the following details:

- Valve type and valve size
- Type ... Control Thermostat
- Model number or material number
- Upstream and downstream pressure
- Temperature and process medium
- Min. and max. flow rate in m³/h
- Is a strainer installed?
- Installation drawing showing the exact location of the regulator and all the additionally installed components (shut-off valves, pressure gauge etc.)

EB 2173 EN



SAMSON AKTIENGESELLSCHAFT
Weismüllerstraße 3 · 60314 Frankfurt am Main, Germany
Phone: +49 69 4009-0 · Fax: +49 69 4009-1507
samson@samsongroup.com · www.samsongroup.com